

SERVO DRIVES

Profilex
SYSTEMS

Profilex s.a.

6b, Z.I. In den Allern
L-9911 Troisvierges
Phone LU : +352 99 89 06
Phone BE : +32 28 88 16 29
Fax : +352 26 95 73 73

info@profilex-systems.com
www.profilex-systems.com



The wide range of drive products allows rapid implementation of simple applications with two end positions, up to complex, high-precision multi-axis applications with synchronization to a main electronic shaft.

The servo drives cover a wide range in terms of performance. Controlling small actuators with low power as well as high-power servomotors with direct feed from the three-phase network can be realized.

LinMot Servo Drives

LinMot Servo Drives are highly integrated inverters with one or more power elements, for controlling the motors, and an intelligent control element with integrated position regulation. The control element performs all drive-related control and monitoring functions. It allows direct position set points, or travel along internally stored motion profiles from the overlaid control, using simple analog or digital signals. Additionally, using the technology functions or a customer-specific software application, complete sequences or functions can be implemented for customerspecific applications.

APPLICATION SOFTWARE

Using a software application, customer-specific applications can be programmed directly in the drive. This is mainly an advantage when very fast sequences need to be implemented, for which the communication speed or computing power of the overlaid control are not sufficient.

TECHNOLOGY FUNCTIONS

Technology functions are generally available functional blocks that provide a complete solution for standard applications. The technology function can take over complete sequence control of a process. With the technology function "winding textile yarns", only a few parameters are provided by the overlaid control, such as the number of windings. The complete winding process then takes place automatically.

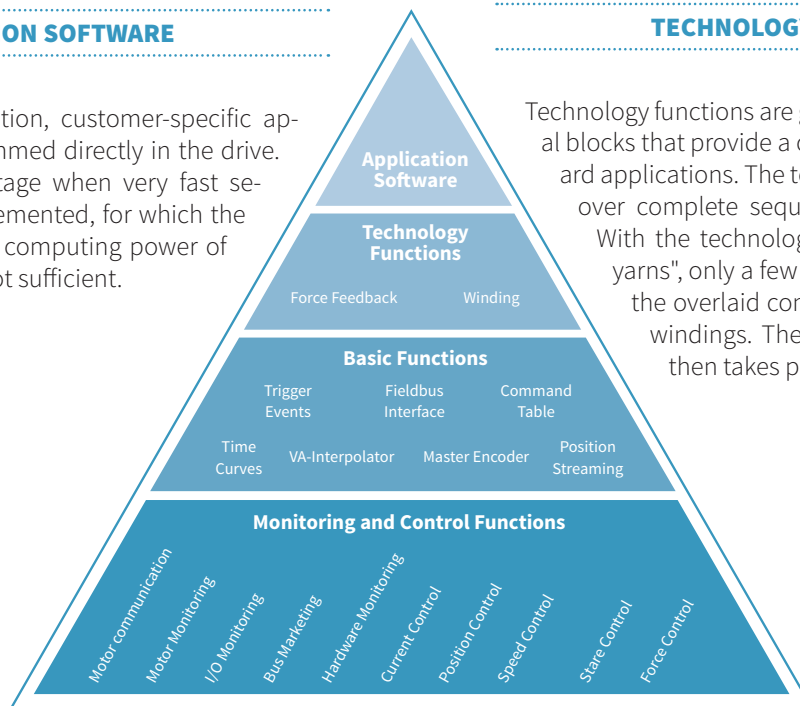

BASIC FUNCTIONS

The basic functions include communication with the overlaid control, generation of target values for speed and acceleration-limited point-to-point motions, travel along motion profiles, synchronization of drives to an electronic main or master shaft, and synchronization in multi-axis applications.

MONITORING AND CONTROL

The basic functions of the Servo Drive, such as position and current control; control and monitoring of the power element; and monitoring the motor temperature, power, and position are handled by the control, monitoring, and regulation element, which also controls the entire finite state machine of the drive.

SPS LIBRARIES AND PROGRAMMING EXAMPLES

LinMot Drives have all common fieldbus interfaces available for connection to a master controller. In order to realize simple control concept integration, extensive function blocks and programming examples are provided for the customer. These function blocks allow for direct and quick LinMot drive integration. The function blocks run standard functions as well as commands such as drive parameterization and configuration directly from the controller. The complete drive

configuration of the corresponding axis is thus stored on the controller. Maintenance or replacement can be easily realized via automatic drives detection and configuration over the communication bus. Thus manual and time-consuming configuration of the drives in case of failure is eliminated.

Characteristics

POINT-TO-POINT MOTIONS

Because of their high dynamic capabilities, long life, and ability to travel to several positions, LinMot linear motors are often used as a replacement for pneumatic cylinders.

Various end positions can be stored in the drive and are invoked via digital signals, just as with a pneumatic cylinder. Once the end position is reached, this is reported to the overlaid control via the In-position signal on a digital output. Speed and acceleration can be configured freely for each motion.

NC MOTION

Travel along paths from an overlaid NC drive can be implemented via the +/-10V interface, or in streaming mode (PVT, PV).

The predetermined points are calculated rapidly, so that even irregular and complex curves are realized dynamically.

HIGH-END APPLICATIONS

Complex applications with synchronization to a main or master shaft can be implemented without trouble using the integrated master encoder interface. All incoming signals from the main shaft are processed by the LinMot Drive and depend on the movement type of the linear motor.

Together with a high-resolution, external position sensor, even high-precision positioning tasks in μm range can be handled.

MULTI-AXIS OPERATION

In multi-axes or linked operation, the master encoder interface can control both individually and synchronous to a main or master shaft.

For complex designs, several axes can be synchronized in master-booster or master-gantry mode. This allows simple implementation of portal designs with two synchronized axes, which are controlled by the overlaid control as a single axis.

LINEAR AND ROTARY DRIVES

Using LinMot Servo Drives, rotary servomotors can be used as well as linear motors, or any 1/2/3-phase actuators.

Primarily in assembly automation and feeding applications, small, light brushless DC motors (EC motors) are often needed to rotate a gripper about the Z-axis. The flexibility of the Servo Drive allows such rotary motors to be integrated into the existing controls concept in the same simple manner as linear motors.

STANDARDIZED DEVICE PROFILES

To simplify the integration of different axes, the C Series Servo Drives are equipped with PROFIdrive, Sercos III, SoE (SercosOver-Ethercat) and CoE (CiA402). By using device profiles, the integration of „foreign“ Drives in the motion control is simplified. Further positive aspects are the automatic data exchange in real time and the increase of determinism in the system.

PLUG AND PLAY

LinMot motors with the plug and play functionality are automatically recognized by the A1100 / C1200 / C1100 / E1200 / E1400 servo drives and are immediately ready for use.

The servo drive reads these values when it boots up, and sets the parameters accordingly. This automatic device detection eliminates the selection of the required model parameters from an extensive library. Without having the configuration software to boot, first commands can be sent directly by the PLC control.

INTEGRATED SAFETY FUNCTION

In order to prevent unintended startup, the model C1200 / C1100 / E1200 / E1400 drives have an STO function to safely shut off the output stage. The drive cannot produce any more force when shut off using the "Safe Torque Off" function. A functional safety is currently under preparation and can already be solved today with external components.

CERTIFICATION

The current LinMot Drives are marked with CE and approved as components according to the UL regulation for variable-frequency controllers. Thus they meet the requirements for the US and Canadian market.

Configuration with LinMot Talk

LinMot Talk configuration software is a Windows-based interface that supports the user during start-up and configuration of the LinMot Servo Drives. The software has a powerful, modular, graphical interface that covers all the tasks surrounding the LinMot Servo Drive. Using LinMot Talk PC interface, the engineer can configure LinMot servo drives. The motors are also monitored during operation and the current motion sequences are analysed (monitoring). The integrated control panel gives the user direct access to the control and status words, as well as all commands that are invoked by the upper-level controller.

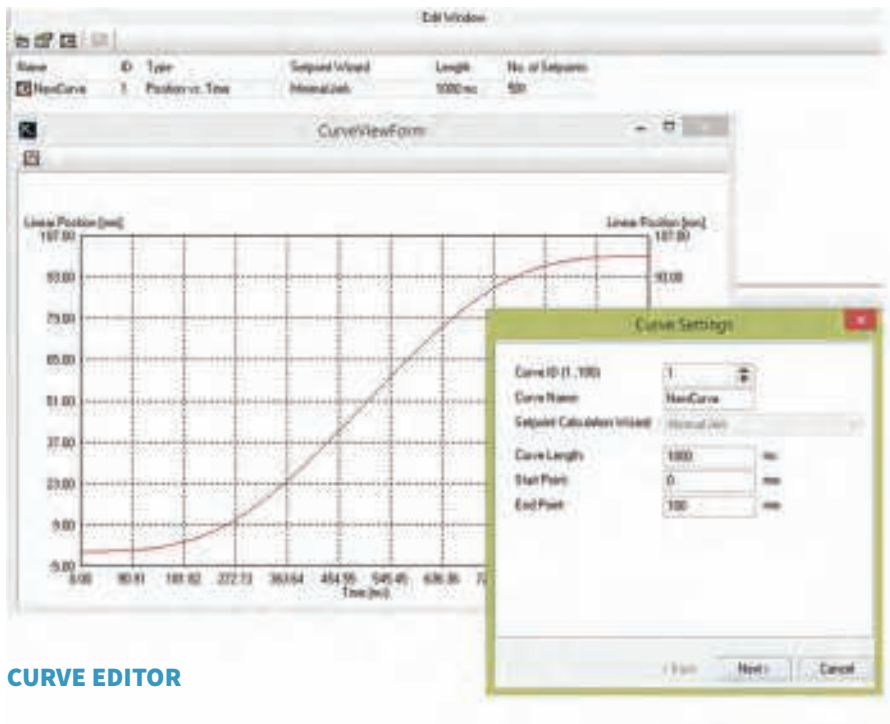

CURVE EDITOR

PARAMETERIZATION

Using the "Parameter Inspector," the drives are parameterized in a simple manner. The user has a wide range of adjustments available for operating modes, error management, warning messages, and regulating parameters. Entire parameter sets can be stored, loaded, and printed out.

CURVE EDITOR

The "Curve Editor" allows creation of travel curves. In addition, existing curves can be loaded, stored, edited, combined, and printed out. Further, complex motion sequences can be generated as desired in MS Excel, and loaded into the drive.

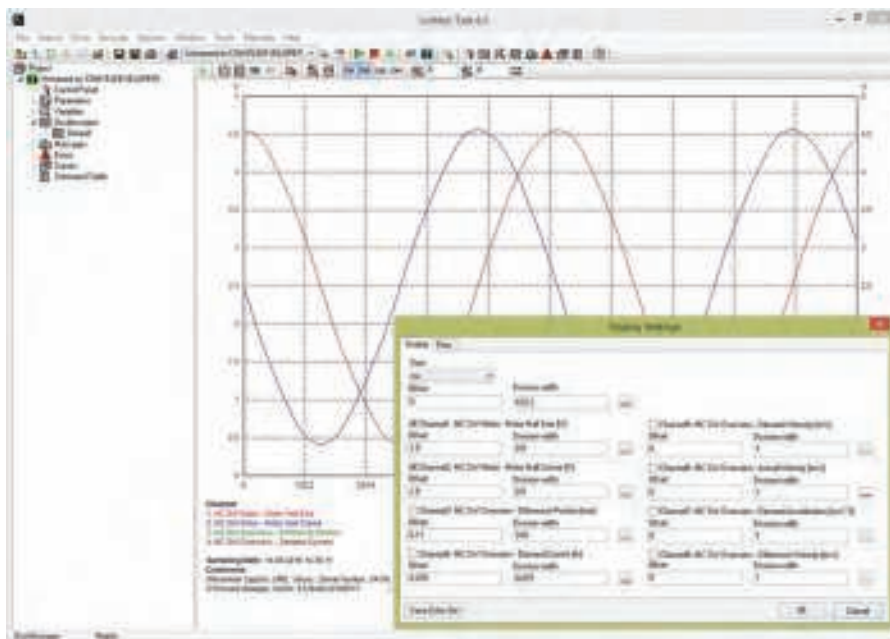

OSCILLOSCOPE

OPTIMIZATION

The integrated oscilloscope helps the user during start-up and optimization of the Parameterization Optimization Monitoring drive system. Internal variables, such as the target and actual position, can be shown in real time on the screen, and then printed out. The displayed data can be stored in CSV format for further processing in MS Excel, or stored for documentation purposes.

MONITORING

Using the "Error Inspector," the user can read out stored errors, as well as the currently active warnings and error messages in the LinMot Servo Drive. A list of the last error messages are stored in non-volatile memory on the Servo Drive, together with the operating hours counter.

Overview Servo Drives



A1100

Space-saving servo drive for instrument engineering



C1100

Compact drive for an ideal use in point-to-point applications.



C1200

Servo Drive for demanding tasks with axis, NC synchronization and an industrial ETHERNET interface.



E1200

High-End Servo Drive with configuration via ETHERNET.



C1400

Servo Drive with direct power supply for simple motions as well as complex axis synchronization. Designed to control the P10 motor family.



E1400

Servo Drive for P10 motors with direct main supply and 3x400 VAC technology. Equipped with an ETHERNET Config. interface.

Technical Specifications

	A1100	C1100	C1200
Motor Supply			
	24...72VDC	24...72VDC	24...72VDC
Motor Current			
	8A _{pk}	25A _{pk}	25A _{pk}
Control of			
LinMot Motors P0x/ PR01	•	•	•
LinMot Motors P10			
Rotary Motors		•	•
EC02 Motors		•	•
AC Servo Motors			
3rd Party Motors		•	•
Functionality			
	Point-to-Point	Point-to-Point	Point-to-Point
	Command Table	Closed Loop Force Control	Limited jerk motion commands
	Motion Profiles	Command Table	NC Motion
		Motion Profiles	Closed Loop Force Control
			Command Table
			Motion Profiles
Ethernet & Fieldbuses			
	CANOpen	PROFINET	PROFINET
		EtherCAT (LinMot Profile)	PROFINET Profidrive
		EtherCAT (CiA402)	EtherNet/IP
		EtherCAT (SoE)	Sercos III
		CANOpen	Powerlink
			LinUDP
			EtherCAT
			EtherCAT (CiA402)
			EtherCAT (SoE)
Interfaces			
Analog Inputs 0..10V / +-10V	1 / 0	1/1	1/1
Number of digital Inputs / Outputs	6 / 2	4/2	4/2
Brake Output	(-)	24V/0.5A	24V/0.5A
External Encoder			
		A/B/Z (RS422)	A/B/Z (RS422)
		SSI	SSI
		BISS	BISS
			EnDat
Timings			
Min. Bus Cycle Time	250 µs	250 µs	125 µs
PWM Frequency	16 kHz	16 kHz	16 kHz
Trigger Commands	≥ 250 µs	≥ 250 µs	≥ 125 µs
Position Drive	250 µs	250 µs	125 µs
Configuration			
RS 232	•	•	•
ETHERNET			•
ETHERNET -Maintenance			

E1200	C1400	E1400
24...72VDC	1x200...240VAC	3x400...480VAC
32A _{pk}	15A _{pk}	28A _{pk}
•		
•	•	•
•	•	•
•	•	•
Point-to-Point	Point-to-Point	Point-to-Point
NC Motion	Limited jerk motion commands	Limited jerk motion commands
Master Encoder / CAM	NC Motion	NC Motion
Belt Synchronization	Master Encoder / CAM	Master Encoder / CAM
Master Booster (up to 4 slaves)	Belt Synchronization	Belt Synchronization
Master Gantry (up to 4 slaves)	Closed Loop Force Control	Master Booster (up to 4 slaves)
Winding Application	Command Table	Master Gantry (up to 4 slaves)
Closed Loop Force Control	Motion Profiles	Winding Application
Command Table		Closed Loop Force Control
Motion Profiles		Command Table
		Motion Profiles
PROFINET	PROFINET	PROFINET
PROFINET Profidrive	PROFINET Profidrive	PROFINET Profidrive
EtherNet/IP	EtherNet/IP	EtherNet/IP
Sercos III	Sercos III	Sercos III
Powerlink	Powerlink	Powerlink
LinUDP	LinUDP	LinUDP
Profibus DP	CANOpen	Profibus DP
CANOpen	EtherCAT	CANOpen
EtherCAT	EtherCAT (CiA402)	EtherCAT
EtherCAT (CiA402)	EtherCAT (SoE)	EtherCAT (CiA402)
EtherCAT (SoE)		EtherCAT (SoE)
LinRS		LinRS
2/1	1/1	2/1
8	4/2	8
24V/1.0A	24V/1.5A	24V/1.5A
A/B/Z (RS422)	A/B/Z (RS422)	A/B/Z (RS422)
Sin/Cos (1Vpp)	SSI	SSI
SSI (only position recovery)	BISS	BISS
	EnDat	EnDat
200 μs	250 μs	250 μs
20 kHz	8 kHz	8 kHz
≥ 100 μs	≥ 125 μs	≥ 125 μs
100 μs	125 μs	125 μs
•	•	•
•	•	•
•		•



LinMot®

LinMot®

LinMot®

1 2 3 4 5 6 7 8
S2 S1
CTS 206-B T340

1 2 3 4 5 6 7 8
S2 S1
CTS 206-B T340

1 2 3 4 5 6 7 8
S2 S1
CTS 206-B T340

X33 STO
RELAYS

WARN ERROR
EN 24V OK

11 AnIn-
10 AnIn+
9 AnIn-
8 In
7 In
6 In
5 In
4 Out
3 Out
2 24VDC
1 0GND
M LOGIC SUPPLY / CONTROL

X33 STO
RELAYS

X33 STO
RELAYS

X33 STO
RELAYS

X33 STO
RELAYS

C1100

C1100

X33 SYSTEM

LinMot®

LinMot®

SERIES A1100



- ✓ Absolute / relative positioning commands
- ✓ Limited jerk motion commands
- ✓ Time Curves
- ✓ PLC or Stand-Alone Solutions
- ✓ Digital IO's
- ✓ Supports Plug and Play
- ✓ CE / UL / CSA

Servo Drive A1100

Series A1100 drives are compact servo drives with 32-bit position resolution and integrated power stage, for linear motors.

The drives are suitable for simple and standard position tasks with point-to-point motions and have a plug and play function.



11

CONNECTION TO MACHINE CONTROL PROCESS AND SENSOR INTERFACES LOGIC AND POWER SUPPLY

The Series A1100 Servo Drives can be actuated by machine controls from many manufacturers or brands, via digital inputs, outputs, serial interface, or by CAN-open interfaces.

Fast process interfaces for direct processing of sensor signals are available as freely programmable analog and digital inputs and fast trigger inputs.

The Servo Drives need two separate power supplies for the logic and power elements.

In an E-stop and safe stop of the drive, only the motor power supply is cut off from the drive. The logic supply and the drive continue to run.

System Integration

Series A1100 Servo Drives have analog inputs and digital inputs and outputs, serial interfaces, and Bus connections. The user is therefore not dependent on the selection of the higher level controller.

Additionally, the drives can be equipped with optional peripherals, such as reference and end stop switches.

With flexibility and a compact form factor, LinMot Series A1100 Servo Drives provide a complete solution for a flexible drive concept in single and multiple axes applications, with linear motors.

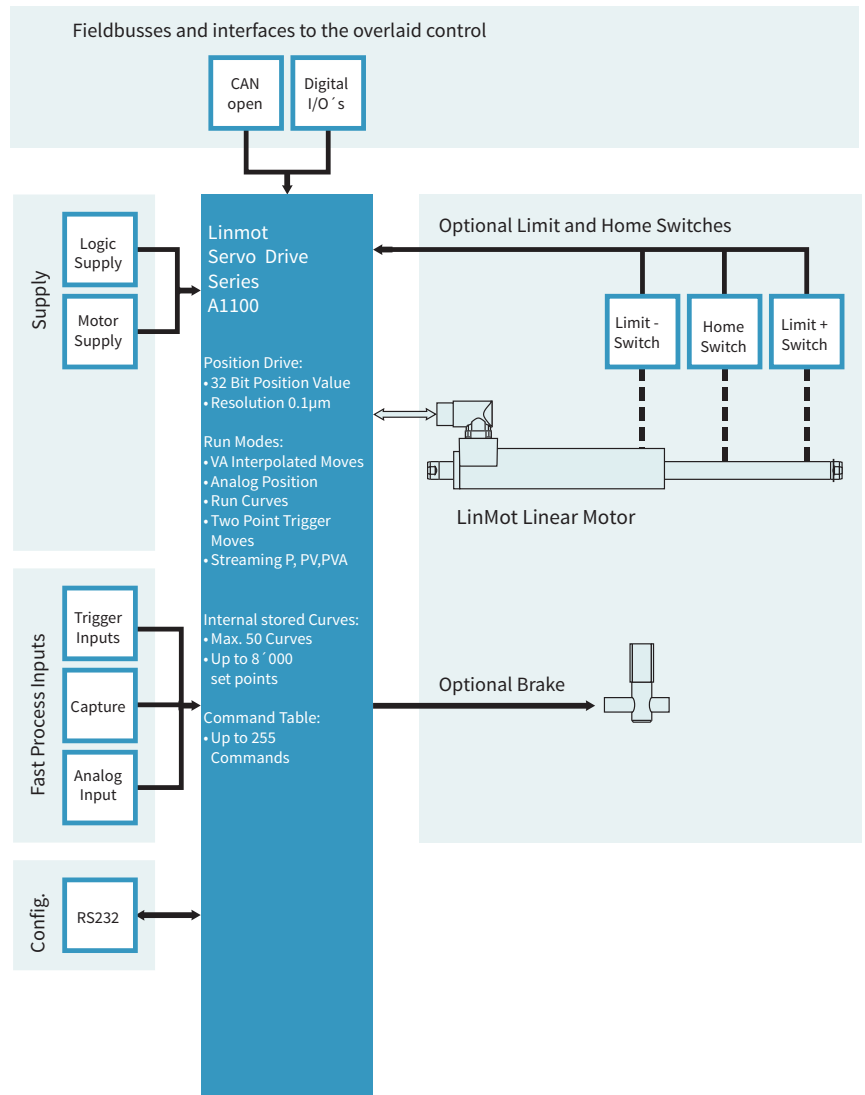

POSITION STREAMING MOTOR INTERFACES CONFIGURATION

With a cyclical target value, or “position streaming,” the overarching NC or CNC drive communicates with the Servo Drive through CANopen.

The position and velocity calculated in the overarching drive is transmitted to the Servo Drive cyclically. The P, PV, or PVA mode is available for this transmission.

A1100 Servo Drives provide all necessary interfaces to operate linear motors with optional external peripherals, such as end position and reference switches.

Parameterization and configuration of the Servo Drive is done via RS232.

LinMot Talk user-friendly PC software is available for configuration. In addition to online documentation, LinMot Talk provides extensive debugging tools, such as an oscilloscope and an error inspector, for simple and rapid start-up of the axes.

INTERPOLATED MOVES

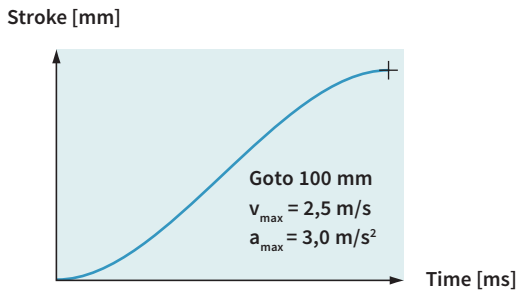

For direct position targets, using absolute or relative positioning, the desired position is reached using acceleration and velocity-limited motion profiles or jerk optimized profiles (jerk limited and Bestehorn). Positioning commands can be invoked via the serial interface, CAN-open or a trigger input.

Stroke range:	±100 m
Position Resolution:	0.1 µm (32Bit)
Velocity Resolution:	1.0 µm/s (32Bit)
Acceleration Resol.:	10.0 µm/s ² (32Bit)

TIME CURVES

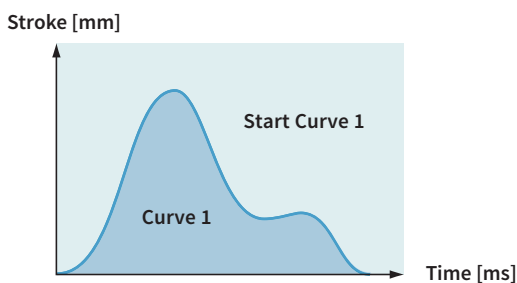

Up to 50 different time curves can be stored in Series A1100 drives, with up to 8,000 individual set points. The motor can thus travel along time curves of any complexity, such as those generated by CAD programs and stored in the drive (Excel CSV format). The time curves can be invoked via the serial interface, fieldbuses or the trigger input.

Stroke range:	±100m
Position Resolution:	0.1 µm (32Bit)
Motion profiles:	Max. 50 Time Curves
Curve points:	Max. 8'000 points

PROFILED MOVES

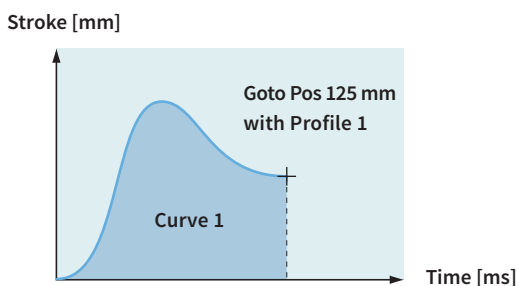

For travel to an absolute position, or shifting by a relative position, any desired motion rules can be stored besides the VA interpolator. They are stored in the drive as motion profiles (Excel CSV format). The positions can be approached, for example, with a sinusoidal motion to optimize power loss, or special reverse optimized motion profiles.

Stroke range:	±100m
Position Resolution:	0.1 µm (32Bit)
Motion profiles:	Max. 50 Time Curves
Curve points:	Max. 8'000 points

SETPOINT STREAMING

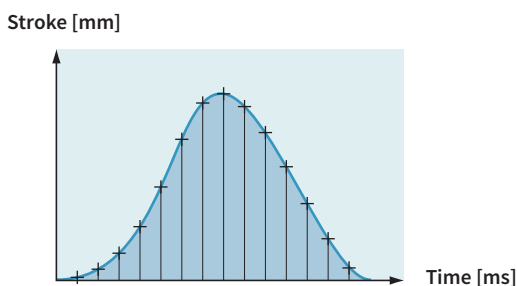

Overlaid NC drives with fieldbus or Ethernet interfaces communicate with the servo drives via "Position Streaming". The position and velocity calculated in the overlaid control is transmitted to the Servo Drive cyclically. The P, PV, or PVA mode is available for this transmission.

Position Resolution:	32 Bit
Velocity Resolution:	32 Bit
Interpolator:	4 kHz
Cycle times:	0.5 - 5 ms

COMMAND TABLE

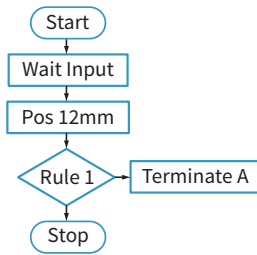

Entire motion sequences with up to 255 individual motion commands can be stored in the Command Table. This is primarily advantageous if complete motion sequences need to be executed very quickly, without dead time from the overlaid PLC. In the Command Table, the programmer has access to all motion commands, internal parameters, and digital inputs and outputs.

Commands: max. 255
Cycle time: 250 µsec

ANALOG POSITION

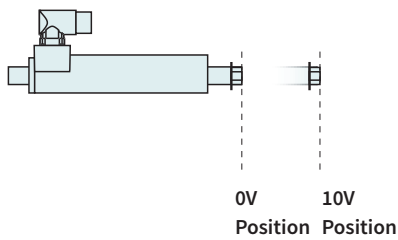

For an analog position target, the linear motor travels to a position proportional to the input voltage. The position is either scanned continuously, or only after a rising edge of the trigger signal. In order to prevent uncontrolled jumps in position, the motor travels to the positions with a programmable maximum acceleration and velocity (VA interpolator).

Inputs: Analog Input X44
Voltage range: 0-10VDC
Resolution: 10 Bit
Scanning rate: 250 µsec

CANopen *Point to Point*

A1100-GP

- » Absolute & Relative Positioning
- » Time based motion profiles
- » Internally stored Motion Sequences
- » Position Streaming
- » Analog Position Target
- » Customer-Specific Functions

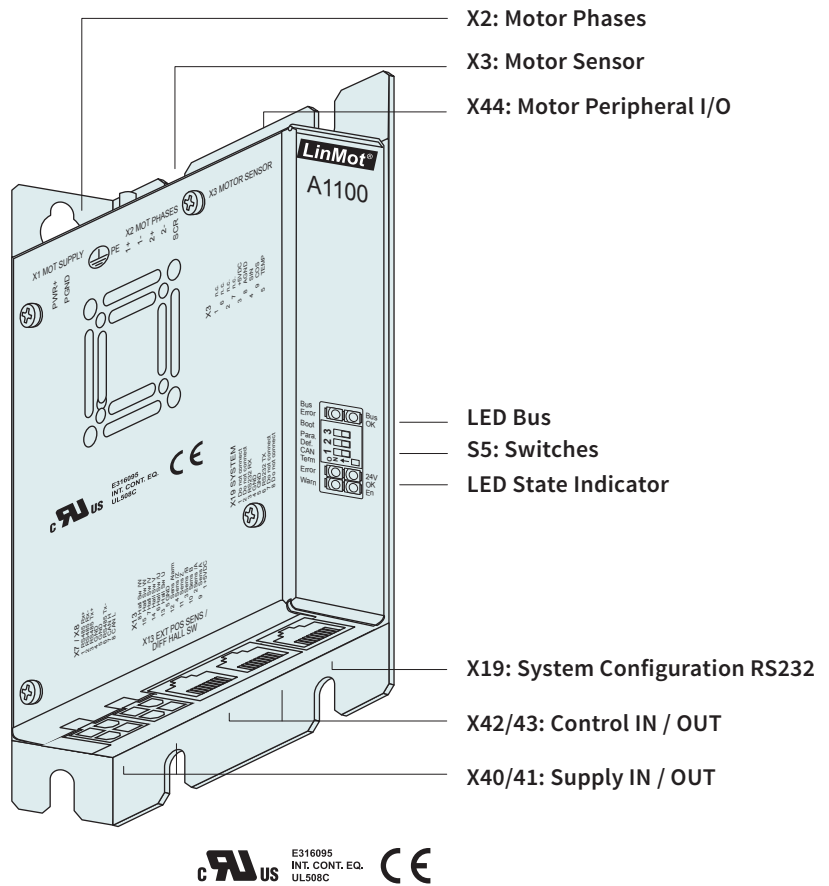

11

CANOPEN

The LinMot A1100-GP drives support the CiA DS301 communications protocol. The following resources are available:
4 T_PDO, 4 R_PDO, 1 T_SDO, 1 R_SDO

The following protocols are also supported by the drives:

- » NMT Error Control (Nodeguarding Protocol or HeartBeat Protocol)
- » PDO (Transmission type 1 to 254)
- » SDO Upload and Download
- » NMT (Start, Stop, Enter PreOp, Reset Node, Reset Communication, Boot-Up Message)

REPLACING PNEUMATICS

Due to their simple controls via digital inputs and outputs, A1100 drives make excellent substitutes for pneumatic cylinders.

Using digital inputs or CAN bus, the linear motor can move to programmable positions. As soon as the linear motor has reached the set position, the In-Position output is actuated.

The linear motor can thus be controlled like a programmable pneumatic cylinder with end position switches.

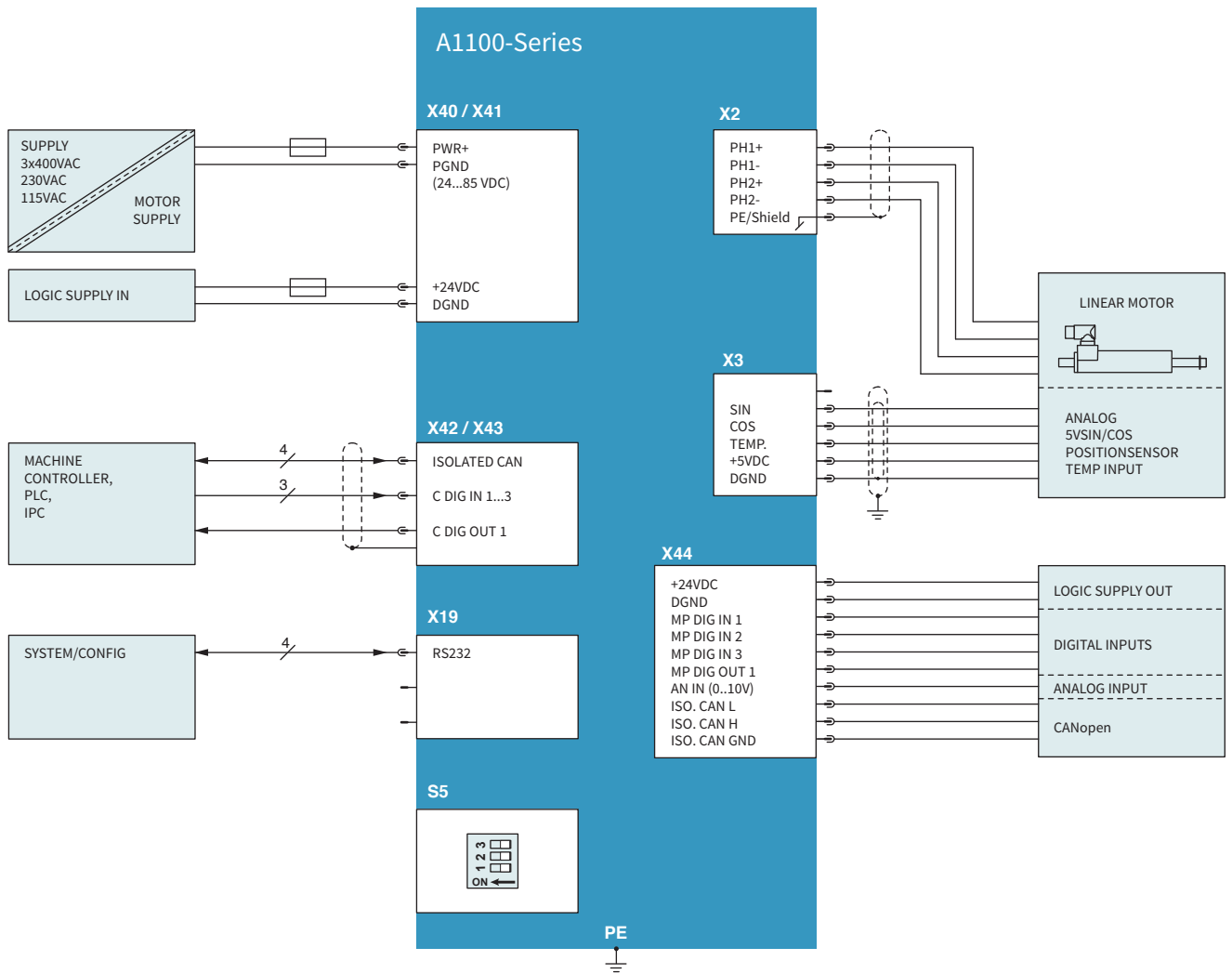

X2 MOTOR PHASES

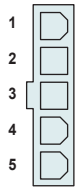

Nr	Designation	LinMot Linear Motor	Color
1	PH1+ /U	Motor Phase 1+	red
2	PH1- /V	Motor Phase 1-	pink
3	PH2+ /W	Motor Phase 2+	blue
4	PH2- /X	Motor Phase 2-	grey
5	SCRN	Shield	

Molex
Mini-Fit Jr.™
Molex Art. Nr.:
50-36-1747

- » Use 60/75°C copper conductors only
- » Cable length <30m
- » 13A max. current per circuit when header is mated to a receptacle loaded with a 45750 Mini-Fit® Plus HCS Crimp Terminal crimped to a 16 AWG wire

X3 MOTOR SENSOR

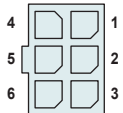

Nr	LinMot Motor
1	DGND
2	Temp
3	Sensor Sine
4	+5VDC
5	(Do not connect)
6	Sensor Cosine

Molex
Mini-Fit 3.0™
Molex Art. Nr.:
43045-0600

- » Use +5V (X3.4) and DGND (X3.1) only for motor internal hall sensor supply (max. 100 mA)
- » Cable length < 30m
- » Caution: Do NOT connect DGND (X3.1) to ground or earth!

MOTOR LINEAR MOTOR WIRING WITH LINMOT MOTOR CABLE (K-, KS- AND KR-TYPES)

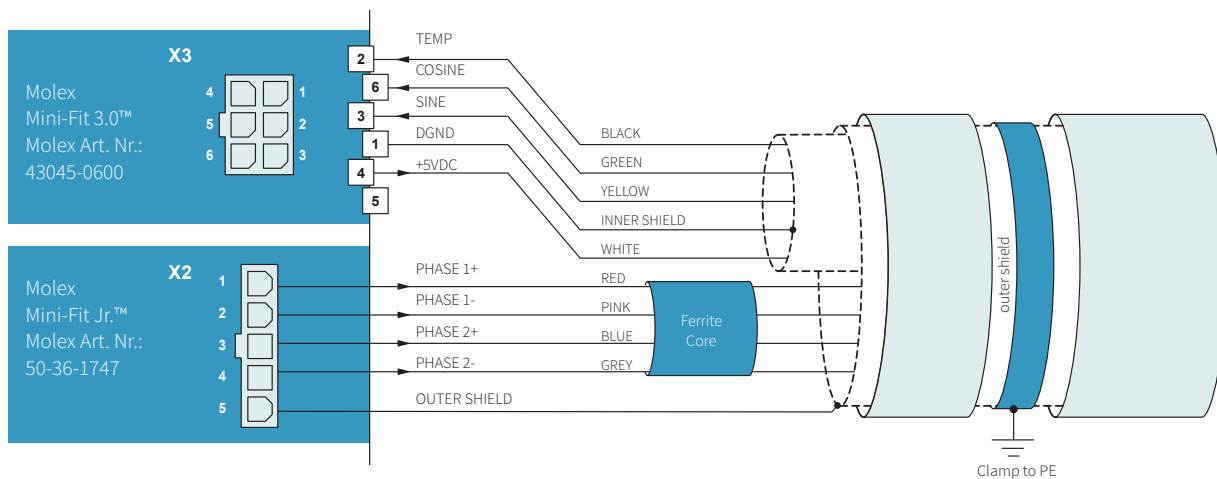

- » For the connection between the linear motor and servo drive, only the specially shielded LinMot cables of type K, KS or KR should be used.
- » The length of the cable can be up to 30 m between the linear motor and the servo drive.
- » Motor cables fabricated by the customer are to be tested with a test voltage of 1500VDC.
- » An improperly fabricated motor cable can damage both the linear motor and the servo drive.
- » The minimum bend radius is to be observed for stationary cables as well as for moving motor cables
- » The motor cable must not be plugged in or unplugged while voltage is still applied.
- » The outer shield of the motor cable has to be clamped to PE as close as possible to the drive.
- » A ferrite core (5mm, 1440hm @ 100MHz, e.g. Würth Elektronik, Art.Nr.: 7427114) has to be mounted around the motor phases as close to the drive as possible.



X40 / X41 SUPPLY IN / OUT

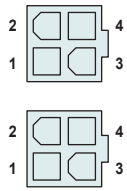

Molex
Mini-Fit Jr.™

Molex Art. Nr.:
50-36-2306

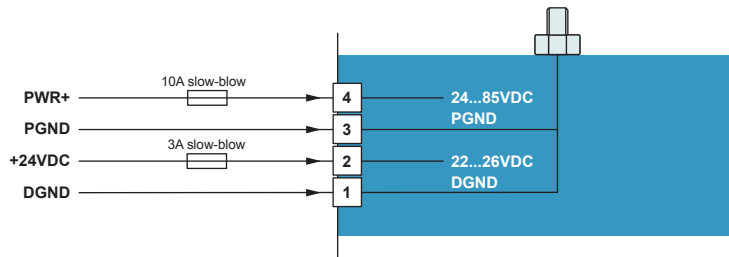

- » Motor Supply: 72VDC nominal, 24...85VDC
- » Absolute max. Rating: 72VDC +20%
- » External Fuse: Motor Supply = 10AT (10A slow blow) / min. 100VDC
Logic Supply = 3AT (3A slow blow) / min. 100VDC
- » If motor supply voltage exceeds 90VDC, the drive will go into error state
- » Use 60/75°C copper conductors only
- » 13A max. current per circuit when header is mated to a receptacle loaded with a 45750 Mini-Fit® Plus HCS Crimp Terminal crimped to a 16 AWG wire

X42 / X43 CONTROL IN / OUT

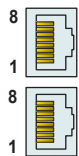

RJ-45
shielded

Nr		
1	C Dig IN 1	Input high voltage: Vin > 16VDC, Input low voltage: Vin < 8VDC
2	C Dig IN 2	Input high voltage: Vin > 16VDC, Input low voltage: Vin < 8VDC
3	C Dig IN 3	Input high voltage: Vin > 16VDC, Input low voltage: Vin < 8VDC
4	CAN GND	
5	CAN GND	
6	C Dig OUT 1	Open Collector Output, 100k Pull-Up to +24VDC
7	Isolated CAN H	
8	Isolated CAN L	
Case	Shield	

- » Use twisted pair (1-2, 3-6, 4-5, 7-8) cable for wiring
- » X42 is internally connected to X43 (1:1 connection)
- » Cable length < 30m.
- » Galvanically isolated CAN transceiver meets the specifications of the ISO11898-2 standard
- » Note: A termination resistor of 120 Ohm can be connected drive internally with the switch S5.1.

X44 MOTOR PERIPHERAL I/O

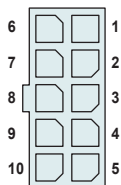

Molex
Mini-Fit 3.0™

Molex Art. Nr.:
43045-1000

Nr		
1	DGND	
2	MP Dig IN 1	Input high voltage: Vin > 16VDC, Input low voltage: Vin < 8VDC
3	MP Dig IN 2	Input high voltage: Vin > 16VDC, Input low voltage: Vin < 8VDC
4	CANGND	Use a separate shielded twisted pair cable for the CAN connection
5	Isolated CAN H	Use a separate shielded twisted pair cable for the CAN connection
6	+24VDC OUT	Max. Current: 2.5A
7	MP Dig OUT 1	Open Collector Output, No Pull-Up, Max. Current: 1.4A
8	MP Dig IN 3	Input high voltage: Vin > 16VDC, Input low voltage: Vin < 8VDC
9	AN IN (0...10V)	Analog Input 0V...10V
10	Isolated CAN L	Use a separate shielded twisted pair cable for the CAN connection

- » Galvanically isolated CAN transceiver meets the specifications of the ISO11898-2 standard
- » The CAN bus on X44 is the same one as on X42/43
- » Note: A termination resistor of 120 Ohm can be connected drive internally with the switch S5.1.
- » Use a separate shielded cable with a twisted pair for CAN L and CAN H when connecting the CAN bus to X44. Clamp the shielding of the cable as close as possible to the drive to PE.
- » Cable length < 30m

X19 SYSTEM

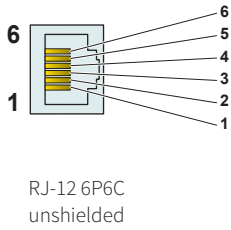

Nr	Description
1	RS232 Tx
2	GND
3	GND
4	RS232 Rx
5	(Do not connect)
6	(Do not connect)

BUS LEDS BUS STATE DISPLAY



BUS State Display	
Green	OK
Red	Error

The use of these LEDs depends on the type of fieldbus which is used. Please see the corresponding manual for further information.

S5



S5.3	Bootstrap (Default = off)
S5.2	Parameter Default (Default = off)
S5.1	CAN Termination (Default = on)

LEDS STATE DISPLAY



State Display	
Green	24V Logic Supply OK
Yellow	Motor Enabled / Error Code Low Nibble
Yellow	Warning / Error Code High Nibble
Red	Error

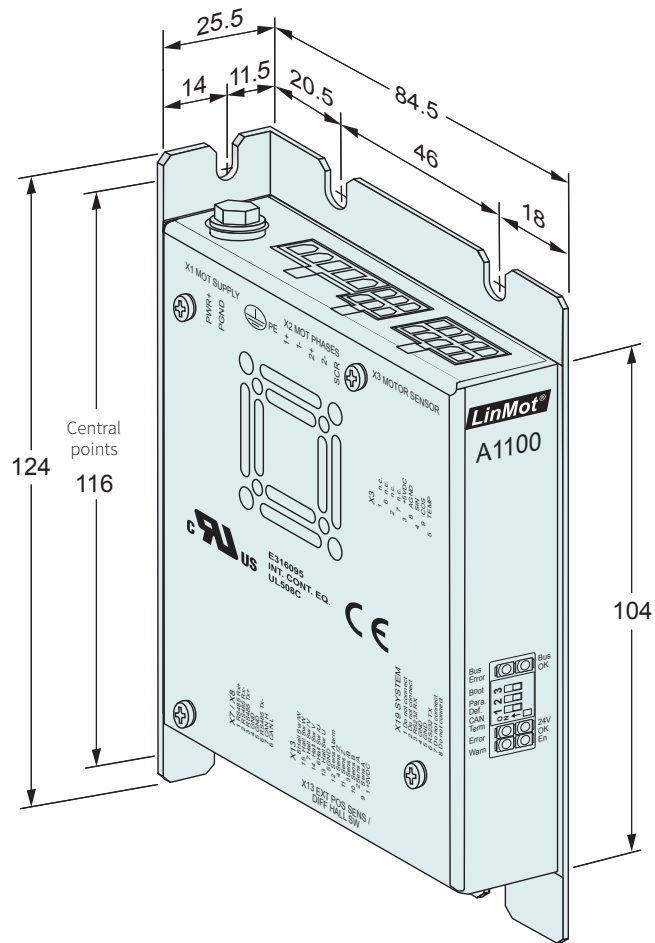

Dimensions in mm
Mounting points for M3 screws

A1100 Single axis drive			
Width	mm (in)	25.5	(1.0)
Height	mm (in)	124	(4.9)
Depth	mm (in)	84.5	(3.3)
Weight	g (lb)	340	(0.75)
Case	IP	20	
Storage temperature	°C	-25...40	
Transport temperature	°C	-25...70	
Operating temperature	°C	0...40 at rated data (UL) 40...50 with power derating	
Relative humidity	%	95 (non-condensing)	
Pollution	IEC/EN 60664-1	Pollution degree 2	
Max. case temperature	°C	70	
Max. power dissipation	W	30	
Min. distance between drives	mm (in)	20 (0.8) 50 (2)	horizontal vertical

Servo Drive		
Item	Description	Part Number
A1100-GP-LC-0S-000	Mini CANopen Drive (72V/8A)	0150-2499

Accessories		
Item	Description	Part Number
DC01-X44-4m	Cable IO´s for A1100/X44, 4 m flying leads	0150-3553
DC01-X40-4m	Cable Supply A1100/X40, 4 m flying leads	0150-3545
DC01-X40/41-0.15 m	Cable IO for A1100/X40-X41, 0.15 m daisy chain	0150-3552

SERIES C1100



- ✓ Absolute / relative positioning commands
- ✓ Limited jerk motion commands
- ✓ Time Curves
- ✓ PLC or Stand-Alone Solutions
- ✓ Digital and Analog IO's
- ✓ Safe Torque Off
- ✓ Interface for optional incremental or absolute sensor
- ✓ Supports Plug and Play
- ✓ CE / UL / CSA

Servo Drive C1100

Series C1100 servo drives are axis controllers, with 32-bit position resolution and an integrated power stage, for linear motors and rotary drives.

The controllers are suitable for simplest and standard positioning tasks with point to point motions.



CONNECTION TO MACHINE CONTROL

The C1100 servo drives can be actuated by machine controls from many manufacturers or brands, via digital inputs and outputs, over CAN Bus or Industrial Ethernet.

Bus-Interfaces:

- » Profinet
- » EtherCat, SoE, CoE
- » CANopen

Serial Interfaces RS422 / RS485:

- » LinRS

PROCESS AND SENSOR INTERFACES

Fast process interfaces for direct processing of sensor signals are available as freely programmable analog and digital inputs, a fast trigger input, and a capture input.

The safety IO's on Servo Drives with the -1S option with CAN or industrial ETHERNET allows safe torque off (STO) of the drives via control signals, without interrupting the power supply.

Drives with -0S option come without safety IO's and are easier to wire in applications without safety needs.

LOGIC AND POWER SUPPLY

The servo drives have two separate inputs for the logic supply and motor elements.

This has the advantage that the drive and linear motor do not need to be reinitialized when the machine is restarted, since all process data, including the actual position of the linear motor, is still up to date.

System Integration

Flexible hardware enables control of many 1/2/3-phase motors. Thus, low-power rotary servomotors, such as brushless DC motors, can be integrated in the same control concept.

Additionally, the drives can be equipped with optional peripherals, such as reference and end stop switches, high-precision external position sensors, or a mechanical holding brake.

Series C1100 servo drives have analog inputs and digital inputs and outputs, serial interfaces, CAN bus, and Ethernet. The user therefore is not dependent on the selection of the higher level controller. An appropriate interface is available, with associated protocols, for many PLC or IPC solution.

With flexibility and a compact form factor, LinMot Series C1100 servo drives provide a complete solution for a flexible drive concept in single and multiple axes applications, with linear motors and other actuators.

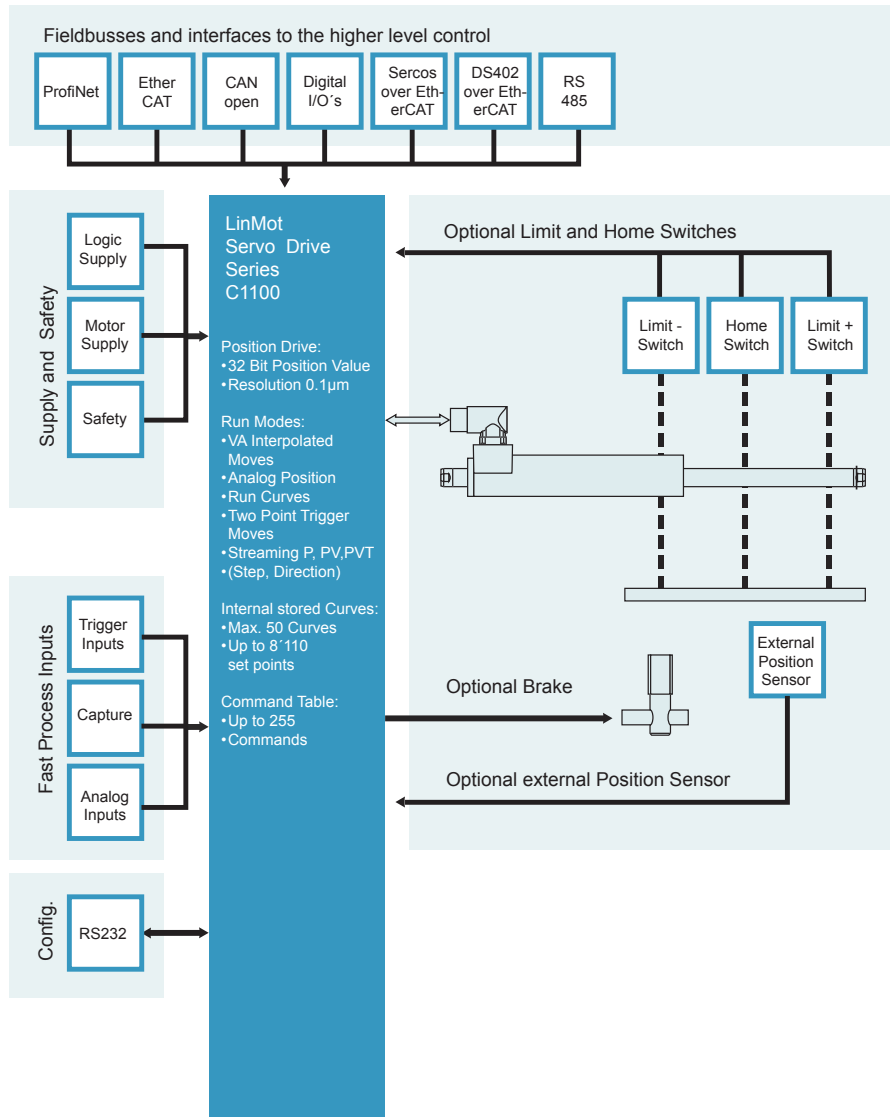

IDEAL FOR POINT TO POINT MOTIONS

Serial interfaces, CAN and industrial Ethernet guarantees flexible and fast communication.

The cost-optimized design of the C1100 series make it the ideal drive for point-to-point motions and replacement of pneumatic cylinders. The control is also characterized by higher speeds, longer service life and high flexibility.

MOTOR INTERFACES

C1100 servo drives provide all necessary interfaces to operate linear or rotary motors with optional external peripherals, such as end position and reference switches, a mechanical brake, or a high-resolution external position sensor.

CONFIGURATION

LinMot Talk, a user-friendly PC software is available for configuration. In addition to online documentation, LinMot Talk provides extensive debugging tools, such as an oscilloscope and an error inspector, for simple and rapid start-up of the Axis.

Fieldbus and Ethernet drives can also be configured directly by the higher level control, by downloading the configuration parameters via Bus/Ethernet

CONNECTION TO MACHINE DRIVE

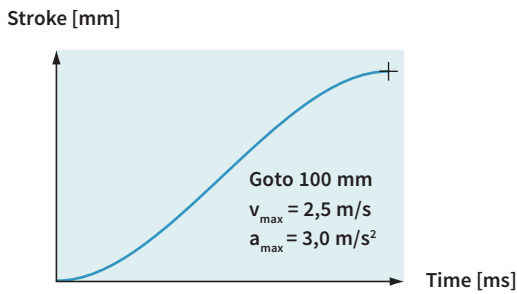

For direct position targets, using absolute or relative positioning, the desired position is reached using acceleration and velocity-limited motion profiles, sine motion profiles or jerk optimized profiles (jerk limited Bestehorn). Positioning commands can be invoked via the serial interfaces, CANopen, Ethernet or a trigger input.

Stroke range:	±100 m
Position Resolution:	0.1 µm (32Bit)
Velocity Resolution:	1.0 µm/s (32Bit)
Acceleration Resol.:	10.0 µm/s ² (32Bit)

TIME CURVES

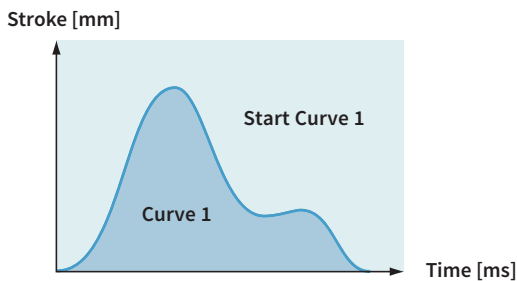

Up to 50 different time curves can be stored Series C1100 drives, with up to 8'110 individual waypoints. The motor can thus travel along time curves of any complexity, such as those generated by CAD programs and stored in the drive (Excel CSV format). The time curves can be invoked via the serial interface, fieldbuses, Ethernet, or the trigger input.

Stroke range:	±100m
Position Resolution:	0.1 µm (32Bit)
Motion profiles:	Max. 50 Time Curves
Curve points:	Max. 8'110 points

PROFILED MOVES

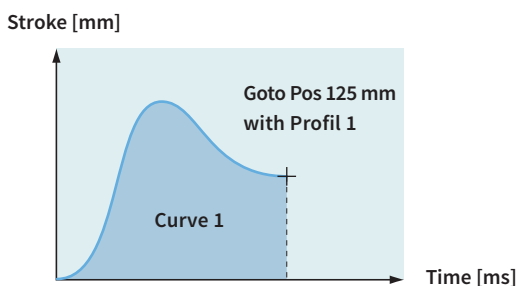

For travel to an absolute position, or shifting by a relative position, any desired motion rules can be stored besides the VA interpolator. They are stored in the drive as motion profiles (Excel CSV format). The positions can be approached, for example, with a sinusoidal motion to optimize power loss, or special reverse optimized motion profiles.

Stroke range:	±100m
Position Resolution:	0.1 µm (32Bit)
Motion profiles:	Max. 50 Time Curves
Curve points:	Max. 8'110 points

SETPOINT STREAMING

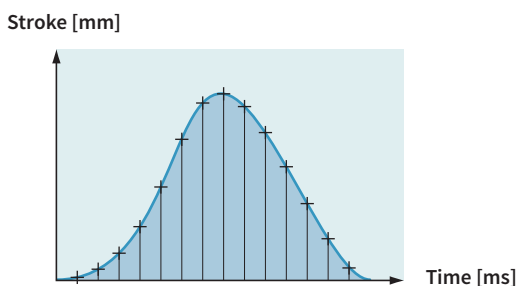

Higher level NC motion controllers with fieldbus or Ethernet interfaces communicate with the servo drives via "Position Streaming". The position and velocity calculated in the higher level control is transmitted to the Servo Drive cyclically. The P, PV, or PVT mode is available for this transmission.

Position Resolution:	32 Bit
Velocity Resolution:	32 Bit
Interpolator:	4 kHz
Cycle times:	0.5 - 5 ms

EASY STEPS

Input 1	Pos 125 mm
Input 2	Pos 250 mm
Input 3	Curve 1
Input 4	Pos -30 mm

With the Easy Steps function, up to 4 positions or independent travel commands can be stored on the drive, and addressed via 4 digital inputs or fieldbus interfaces/Ethernet.

Digital inputs: 4
Interface: X4
Scanning rate: 250 µsec

COMMAND TABLE

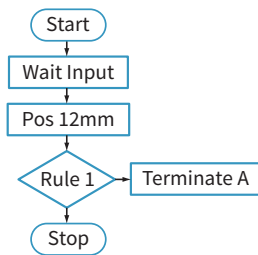

Entire motion sequences with up to 255 individual motion commands can be stored in the Command Table. This is primarily advantageous if complete motion sequences need to be executed very quickly, without dead time from the higher level drive. In the Command Table, the programmer has access to all motion commands, internal parameters, and digital inputs and outputs.

Commands: max. 254
Cycle time: 250 µsec

ANALOG POSITION

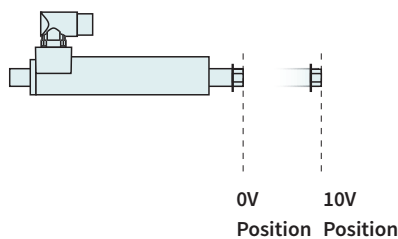

For an analog position target, the linear motor travels to a position proportional to the input voltage. The position is either scanned continuously, or only after a rising edge of the trigger signal. In order to prevent uncontrolled jumps in position, the motor travels to the positions with a programmable maximum acceleration and velocity (VA interpolator).

Inputs: Analog Input X4
Voltage range: 0-10VDC or ±10V
Resolution: 10 Bit
Scanning rate: >=250 µsec (adjustable)

EASY STEPS PARAMETER SCALE

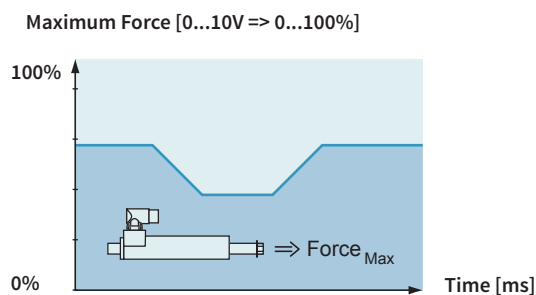

Easy Steps provide the ability to parameterize internal parameters using two analog inputs. If, for example, the maximum motor current is read at an analog input, then the maximum motor force can be provided as analog for freely programmable joining processes.

Inputs: 2 x Analog
Voltage range: 0-10VDC
Resolution: 10 Bit
Scanning rate: 250 µsec

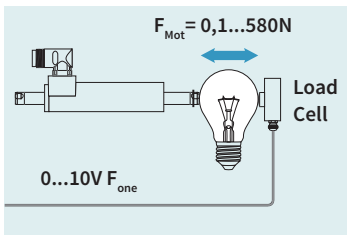
CLOSED LOOP FORCE CONTROL

Using the force control technology function, precise joining processes can be implemented reliably and reproducibly with high-precision force control. For force control, the current motor force is measured with a load cell and controlled in the drive. Joining process or quality checks with high requirements for applied force can be implemented.

Analog input:	0-10V or $\pm 10V$
Resolution:	10 Bit
Min. Force Resolution:	0.1N

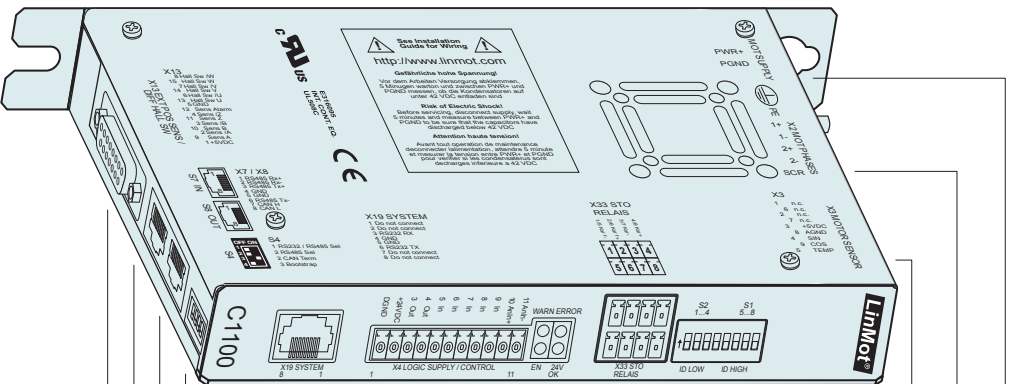

- X1: Motor Supply
- X2: Motor Phases
- X3: Motor Sensor
- S1-2: ID Selector (only C1100-GP-...)
- X33: STO Relais (for -1S option only)
- LED: State Indicator
- X4: Logic Supply / Control
- X19: System Configuration RS232
- LED: RT Bus (only C1150-EC/PN-...)
- S5: Bootstrap Bus Termination (only C1150-EC/PN-...)
- S4: CMD Out (only C1100-GP-...)
- X8/18: CMD In
- X7/17: External Positionsensor
- X13: External Positionsensor

Interfaces	C1100-GP-XC	C1150-EC-XC	C1150-DS-XC	C1150-SE-XC	C1150-PN-XC
LinRS (RS485 / RS422)	•				
CANOpen	•				
ETHERCAT LinMot Profile		•			
ETHERCAT GA402			•		
ETHERCAT SoFe				•	
PROFINET LinMot					•

C1100-GP-XC-0S

C1100-GP-XC-1S

- » Absolute & Relative Positioning
- » Time based motion profiles
- » Internally stored Motion Sequences
- » Position Streaming
- » Analog Position Target
- » Analog Parameter Scaling
- » Force Control Technology Function
- » Customer-Specific Functions

CANopen

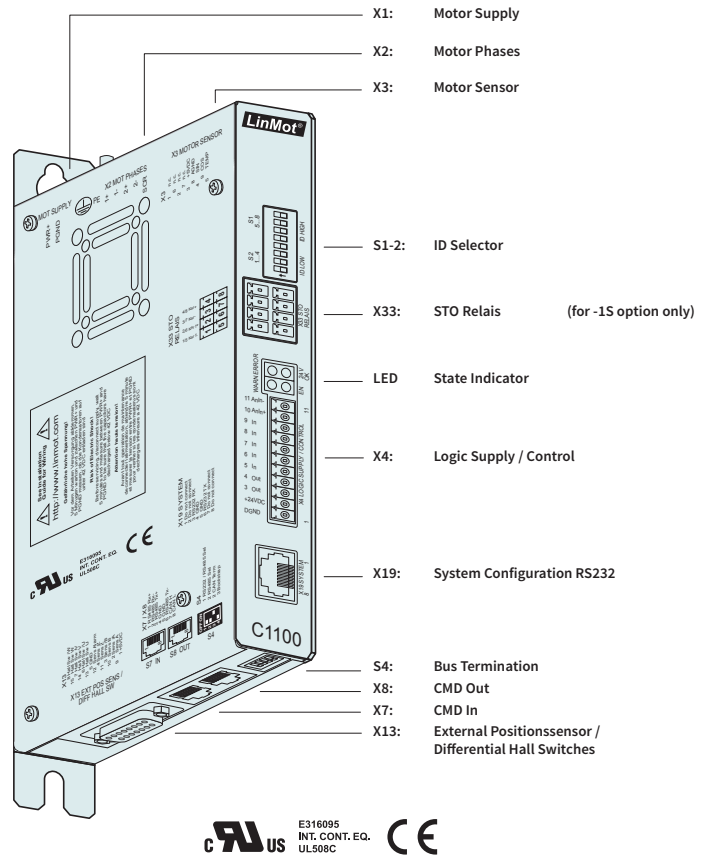

11

CANOPEN

The LinMot C1100-GP drives support the CiA DS301 communications protocol. The following resources are available:

4 T_PDO, 4 R_PDO, 1 T_SDO, 1 R_SDO

The following protocols are supported by the CO drives:

- » NMT Error Control (Nodeguarding Protocol or HeartBeat Protocol)
- » PDO (Transmission type 1 to 254)
- » SDO Upload and Download
- » NMT (Start, Stop, Enter PreOp, Reset Node, Reset Communication, Boot-Up Message)

PROCESS AND SENSOR INTERFACES

C1100-GP servo drives support the following interfaces:

- » CANOpen
- » LinRS

MINIMAL CYCLE TIMES

Min. Bus Cycle:	500 µs
IO update:	500 µs
Trigger Input:	250 µs
Position control loop:	250 µs
Current control loop:	125 µs

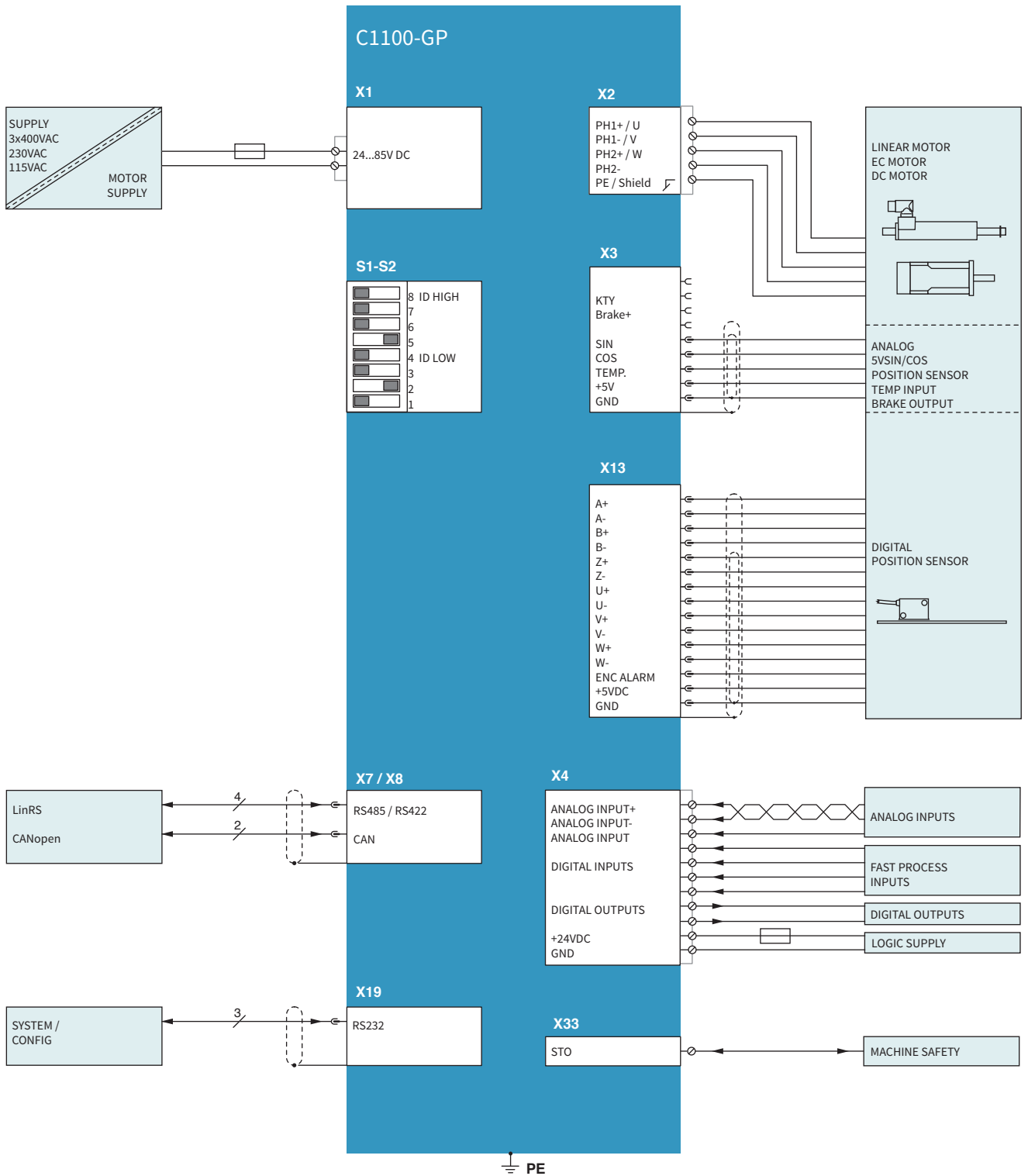

C1150-xx-XC-xS-xxx

- » Absolute & Relative Positioning
- » Time based motion profiles
- » Internally stored Motion Sequences
- » Position Streaming
- » Analog Position Target
- » Analog Parameter Scaling
- » Force Control Technology Function
- » Customer-Specific Functions

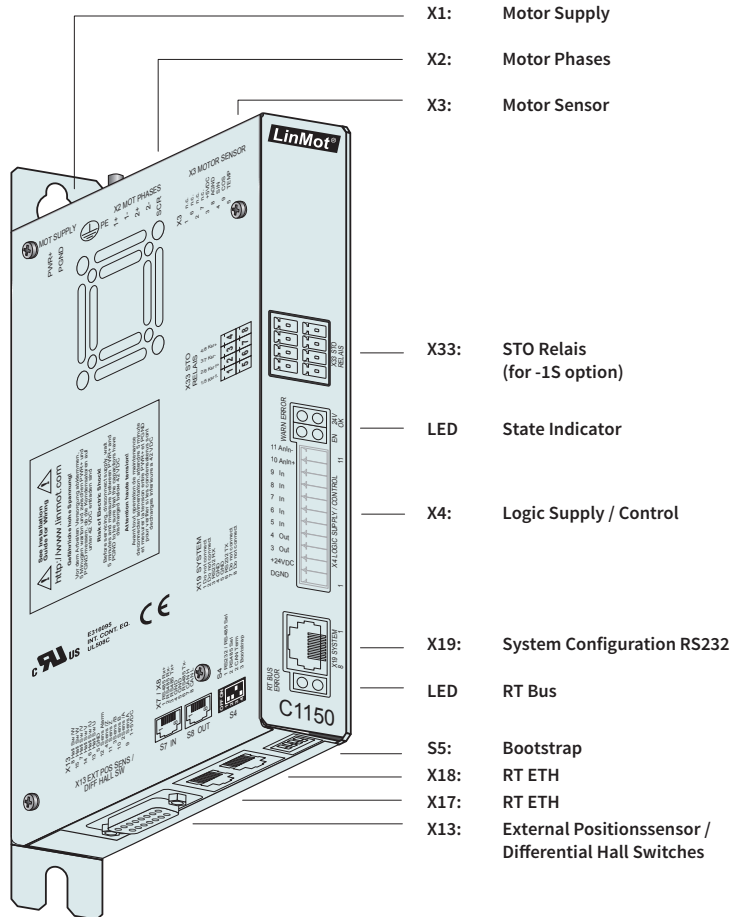

INDUSTRIAL ETHERNET

Series C1150-EC drives allow integration of LinMot linear motors in controls concepts with EtherCAT. The user can integrate Series C1100 drives regardless of the provider of the higher level control.

LinMot drives are available with common industrial Ethernet protocols. Since all Ethernet drives have the same motion command interface, and the control and status word are identical, software blocks that have been implemented once, can be transferred to other motion controllers without a problem.

TECHNICAL DATA

Type: Realtime Ethernet
 Switch/Hub: Integrated 2-Port Switch
 Transfer rate: 10/100MBit/sec

MINIMAL CYCLE TIMES

Bus cycle: 500 µs
 IO update: 500 µs
 Trigger Input: 250 µs
 Position control loop: 250 µs
 Current control loop: 125 µs

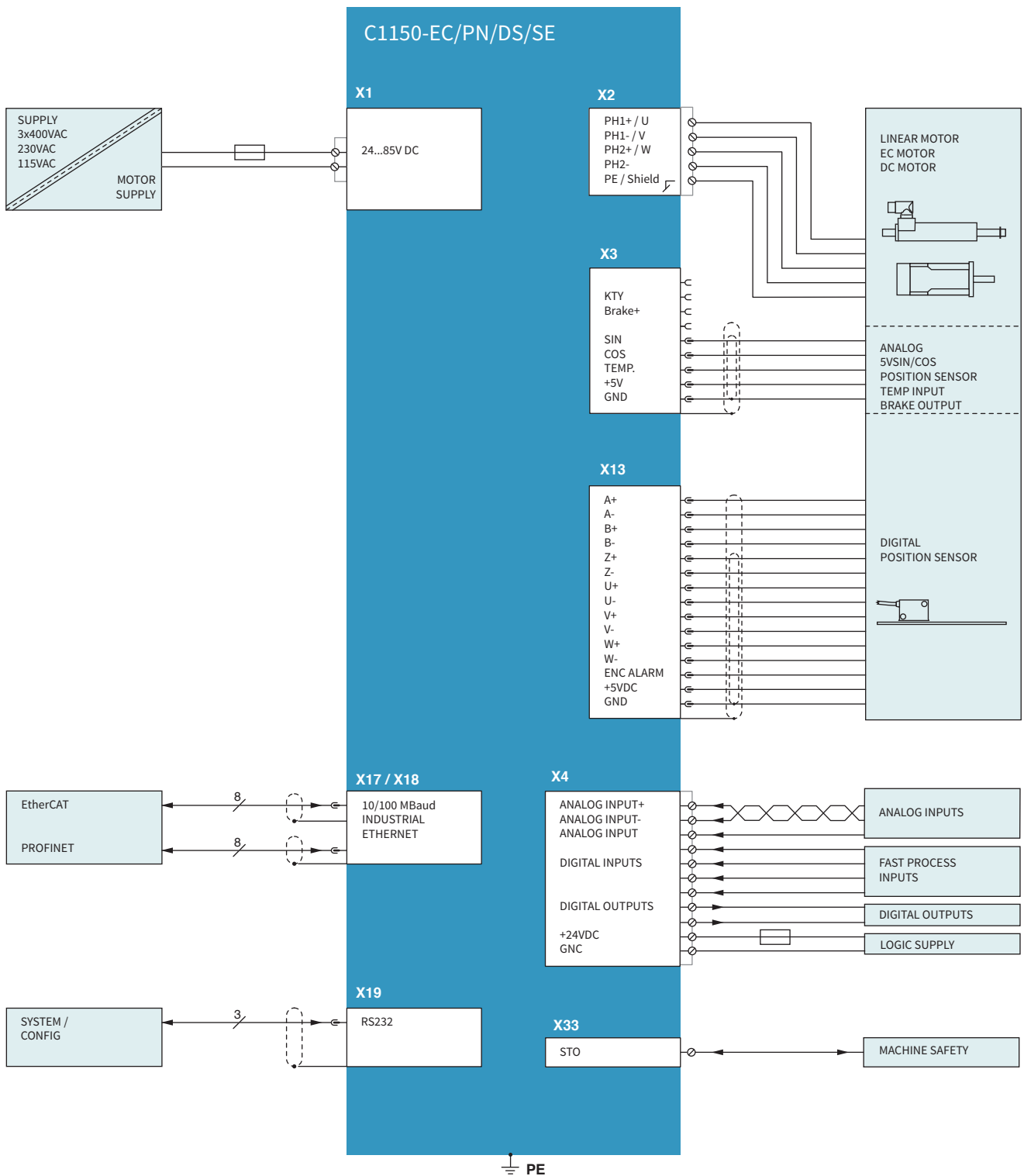

X1 MOTOR SUPPLY

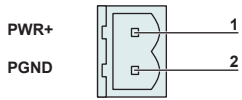

Connector has to be ordered separately

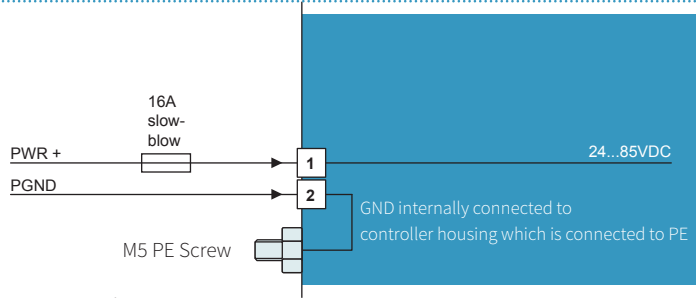

Motor Supply: 72VDC nominal, 24...85VDC
 Absolute max. Rating: 72VDC +20%.
 External Fuse: 16A slow-blow / min. 100VDC
 If motor supply voltage exceeds 90VDC, the drive will go into error state.
 » Use 60/75°C copper conductors only
 » Conductor Cross-Section 2.5mm² (AWG14) max Length 3 m

X2 MOTOR PHASES

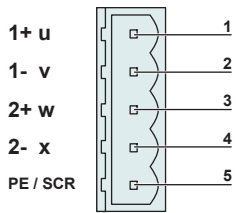

Connector has to be ordered separately

Nr	Designation	LinMot Linear Motor	Color	3-phase EC-Motor	Color
1	PH1+	Motor Phase 1+	red	Motor Phase U	red
2	PH1-	Motor Phase 1-	pink	Motor Phase V	pink
3	PH2+	Motor Phase 2+	blue	Motor Phase W	blue
4	PH2-	Motor Phase 2-	grey	RR-	grey
5	PE/SCRN	Shield		Shield	

» Use 60/75°C copper conductors only
 » Conductor cross-section: 0.5 – 2.5mm² (depends on Motor current) / AWG 21 -14

X3 MOTOR SENSOR / BREMSE

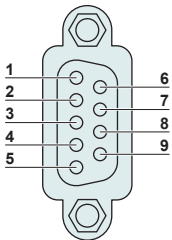

DSUB-9

Nr		LinMot Motor	EC Motor
1		Do not connect	Do not connect
	6	Brake+	Brake+
2		Do not connect	Do not connect
	7	Do not connect	KTY
3		+5VDC	+5VDC
	8	AGND	AGND
4		Sensor Sine	Sensor Sine / Hall Switch U
	9	Sensor Cosine	Sensor Cosine / Hall Switch V
5		Temp In	Hall Switch W
	Case	Shield	Shield

» Use +5V (X3.3) and AGND (X3.8) only for motor internal Hall Sensor supply (max. 100 mA)
 » Cable length < 30 m
 » Brake+: 24V 500mA, 1.4A_{peak}
 » Caution: Do NOT connect AGND (X3.8) to ground or earth!

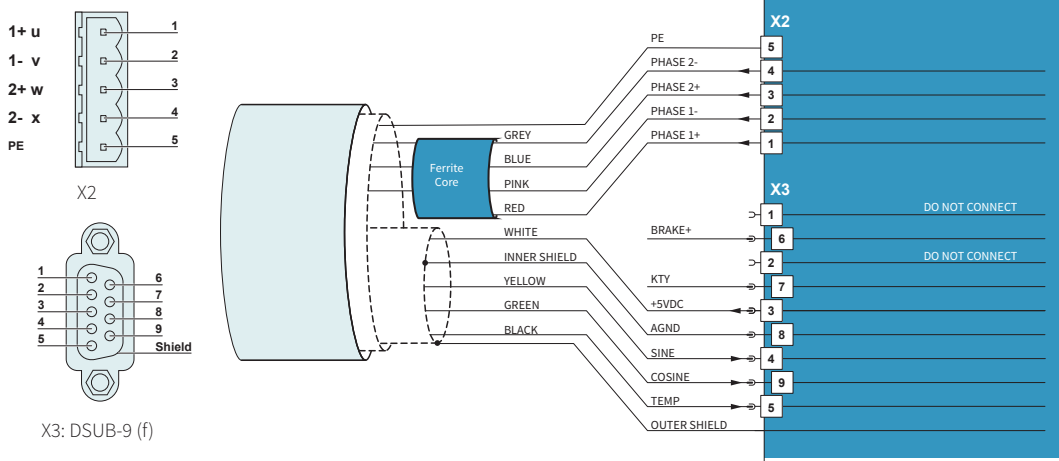

Use Y-style motor cables only (for example K15-Y/C)!

A W-style cable has a different shielding, so it cannot be modified to a Y-style cable!

Phase 2-could be used as RR-with3 phase Motors the other side of regeneration resistor has to be wired to PWR

X4 LOGIC SUPPLY / IO CONNECTION

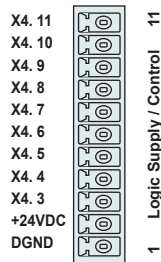

DSUB-9 (f)
Spring cage connector
(has to be ordered separately)

Nr			
11	AnIn-	X4.11	Configurable Analog Input differential (with X4.10)
10	AnIn+	X4.10	Configurable Analog Input differential (with X4.11)
9	AnIn	X4.9	Configurable Analog Input single ended
8	In	X4.8	Configurable Input
7	In	X4.7	Configurable Input
6	In	X4.6	Configurable Input
5	In	X4.5	Configurable Input
4	Out	X4.4	Configurable Output
3	Out	X4.3	Configurable Output
2	+24VDC	Supply	Logic Supply 22-26 VDC
1	GND	Supply	Ground

Inputs: (X4.5...X4.8)
Outputs: (X4.3 & 4.4)
Analog inputs:
X4.9:
X4.10/X4.11:

Supply 24V:

24V / 5mA (Low Level: -0.5 to 5VDC, High Level: 15 to 30VDC)
 24V / max. 500mA, Peak 1.4A (will shut down if exceeded)
 10 bit A/D converted.
 Single ended analog input to GND, 0..10V, Input Resistance: 51kΩ to GND
 Differential analog input, +/- 10V. Common mode range: +/- 5VDC to GND.
 Input Resistance: 11.4kΩ for each signal to GND
 typically 200mA / max. 2.0A (if all outputs "on" with max. load.)
 » Use 60/75°C copper conductors only
 » Conductor cross-section max. 1.5 mm²
 » Stripping length: 10 mm
 » The 24VDC supply for the control circuit (X4.2) must be protected with an external fuse (3A slow blow)

X7 - X8 RS485 / CAN (ON GP DRIVES ONLY)

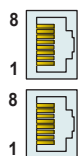

RJ-45

Nr		
1	RS485_Rx+	A
2	RS485_Rx-	B
3	RS485_Tx+	Y
4	NC	
5	GND (1k Ohm to GND)	
6	RS485_Tx-	Z
7	CAN_H	
8	CAN_L	
Case	Shield	

- » Use twisted pair (1-2, 3-6, 4-5, 7-8) cable for wiring.
- » The built in CAN and RS485 terminations can be activated by S4.2 and S4.3.
- » X7 is internally connected to X8 (1:1 connection)

S1 - S2 ADDRESS SELECTORS (ON GP DRIVES ONLY)



S1 (5...8)	Bus ID High (0 ... F). Bit 5 is the LSB, bit 8 the MSB.
------------	---

S2 (1...4)	Bus ID Low (0 ... F). Bit 1 is the LSB, bit 4 the MSB
------------	---

The use of these switches depends on the type of fieldbus which is used. Please see the corresponding manual for further information.

RT BUS LEDS



RT BUS State Display	
Green	OK
Red	Error

The use of these LEDs depends on the type of fieldbus which is used. Please see the corresponding manual for further information.

S4 BUS TERMINATION (ON GP DRIVES ONLY)



Switch 4	Bootstrap
Switch 3	Termination CAN on/off
Switch 2	Termination RS485 on/off
Switch 1	RS232 / RS485

Factory settings: Switch 3 “on”, all other switches “off”

S5 BOOTSTRAP (ON EC AND PN DRIVES ONLY)

S5	Bootstrap (Internal use only)
----	-------------------------------

X13 EXTERNAL POSITION SENSOR DIFFERENTIAL HALL SWITCHES

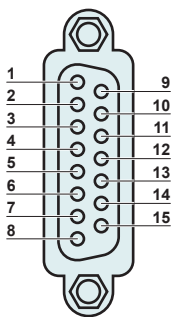

DSUB-15 (f)

Nr	ABZ with Hall Switches	SSI / Biss / EnDat
1	+5V DC	+5V DC
9	A+	A+
2	A-	A-
10	B+	B+
3	B-	B-
11	Z+	Data+
4	Z-	Data-
12	Encoder Alarm	Encoder Alarm
5	GND	GND
13	U+	nc
6	U-	nc
14	V+	nc
7	V-	nc
15	W+	Clk+
8	W-	Clk-
Case	Shield	Shield

Position Encoder Inputs (RS422):

Max. counting frequency: 10 Mcounts/s with quadrature decoding, 100ns edge separation

Differential Hall Switch Inputs (RS422):

Input Frequency: <1kHz

Enc. Alarm In:

5V / 1mA

Sensor Supply:

5VDC, max 100mA

X33 SAFETY RELAYS (ONLY FOR -1S)

X33. 4/8 Ksr+
 X33. 3/7 Ksr-
 X33. 2/6 Ksr f+
 X33. 1/5 Ksr f-

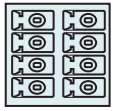

X33 STO RELAYS

Spring cage connector
 (has to be ordered
 separately)

- » Use 60/75°C copper conductors only
- » Conductor cross-section max. 1.5 mm²
- » Stripping length: 10 mm
- » Never connect the safety relays to the logic supply of the drive!

Nr		
4 / 8	Ksr +	Safety Relay 1 / 2 Input positive
3 / 7	Ksr -	Safety Relay 1 / 2 Input negative
2 / 6	Ksr f+	Safety Relay 1 / 2 feedback positive
1 / 5	Ksr f-	Safety Relay 1 / 2 feedback negative

X17 - X18 REALTIME ETHERNET 10/100 MBIT/S (ON EC AND PN DRIVES ONLY)



X17



X18

RJ-45

Nr		
X17	RT ETH In	Specification depends on RT-Bus. Please refer to according documentation.
X18	RT ETH Out	

LEDS STATE DISPLAY



Green	24V Logic Supply OK
Yellow	Motor Enabled / Error Code Low Nibble
Yellow	Warning / Error Code High Nibble
Red	Error

X19 SYSTEM

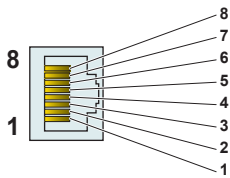

RJ-45

Nr	Descrption
1	(do not connect)
2	(do not connect)
3	RS232 RX
4	GND
5	GND
6	RS232 TX
7	(do not connect)
8	(do not connect)
case	Shield

Use isolated USB-RS232 converter (Art.-No. 0150-2473) for configuration over RS232

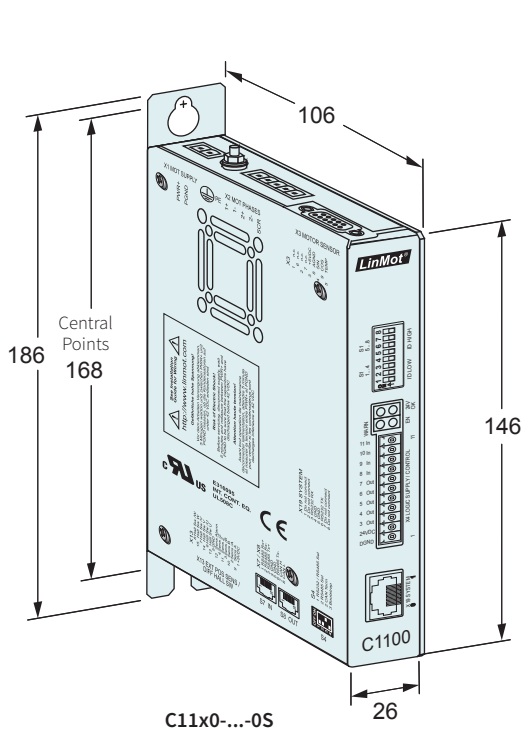

C11x0-...-0S

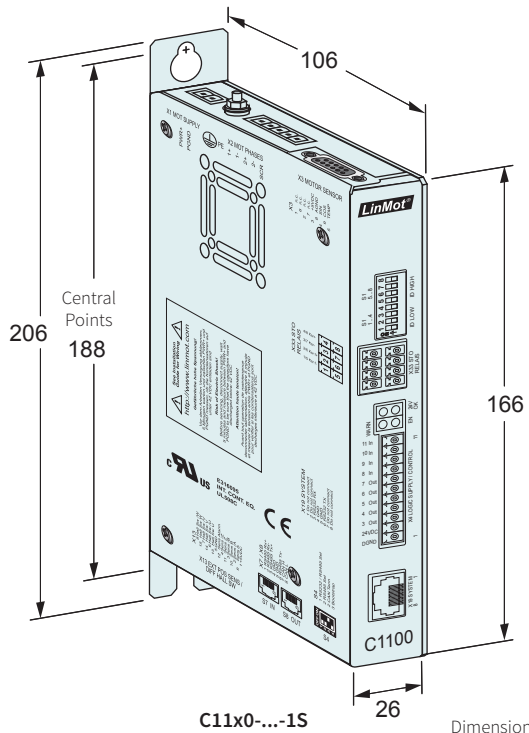

C11x0-...-1S

Dimensions in mm
Mounting points for M5 screws

Servo Drive Series		C11x0-...-0S	C11x0-...-1S
Width	mm (in)		26.0 (1.02)
Height	mm (in)	146 (5.8)	166 (6.5)
Height with fixings	mm (in)	186 (7.3)	206 (8.1)
Depth	mm (in)		106 (4.2)
Weight	kg (lb)	505 (1.21)	650 (1.43)
Mounting Screws		2 x M5	2 x M5
Mounting Distance	mm (in)	168 (6.61)	188 (7.4)
Case IP Code	IP	20	
Storage temperature	°C	-25...40	
Transport temperature	°C	-25...70	
Operating temperature	°C	0...40 at rated date 40...50 with power derating	
Relative humidity		95% (non-condensing)	
Pollution	IEC/EN 60664-1	Pollution degree 2	
Shock resistance (16 ms)	-1S option		3.5 g
Vibration resistance (10-200Hz)	-S option		1 g
Max. case temperature	°C	70	
Max. power dissipation	W	30	
Mounting place		in the control cabinet	
Mounting position		vertical	
Distance between Drives	mm (in)	Without Power Derating 20 (0.8) left/right / 50 (2) top/bottom With Power Derating: 5 (0.2) left/right / 20 (0.8) top/bottom	

Servo Drives		
Item	Description	Part Number
C1100-GP-XC-0S-000	General Purpose Drive (72VDC/25)	0150-2380
C1150-PN-XC-0S-000	ProfiNet Drive (72V/25A)	0150-2384
C1150-EC-XC-0S-000	EtherCAT Drive (72VDC/25A)	0150-2382
C1150-DS-XC-0S-000	EtherCAT CoE Drive (72VDC/25A)	0150-2417
C1150-SE-XC-0S-000	EtherCAT SoE Drive (72VDC/25A)	0150-2625
C1100-GP-XC-1S-000	General Purpose Drive (72VDC/25), STO	0150-2381
C1150-PN-XC-1S-000	ProfiNet Drive (72V/25A), STO	0150-2385
C1150-EC-XC-1S-000	EtherCAT Drive (72VDC/25A), STO	0150-2383
C1150-DS-XC-1S-000	EtherCAT CoE Drive (72VDC/25A), STO	0150-2418
C1150-SE-XC-1S-000	EtherCAT SoE Drive (72VDC/25A), STO	0150-2626

Accessories		
Item	Description	Part Number
DC01-C1X00-0S/X1/X4	Drive Connector Set for C1X00-0S	0150-3527
DC01-C1X00-1S/X1/X4/X33	Drive Connector Set for C1X00-1S	0150-3528
DC01-C1X00/X1	Drive Connector for PWR 72VDC Input	0150-3525
DC01-C1X00/X2	Drive Connector Motor Phases	0150-3526
DC01-Signal/X4	Drive Connector 24VDC & Logic	0150-3447
DC01-Safety/X33 yello	Drive Connector Safety	0150-3451

A series of horizontal dotted lines spanning the width of the page, intended for taking notes.

SERIES C1200



- ✓ Absolute / relative positioning commands
- ✓ Limited jerk motion commands
- ✓ Time Curves
- ✓ Real Time (Streaming)
- ✓ Synchronous control (Drive profiles)
- ✓ PLC or Stand-Alone Solutions
- ✓ Digital and Analog IO's
- ✓ Safe Torque Off
- ✓ Interface for optional incremental or absolute sensor
- ✓ Supports Plug and Play
- ✓ CE / UL / CSA

Servo Drive C1200

Series C1200 servo drives are axis controllers, with 32-bit position resolution and an integrated power stage, for linear and rotary motors. The controllers are suitable for standard and high-end positioning tasks with NC Synchronisation.



CONNECTION TO MACHINE CONTROL

The Series C1200 servo drives can be actuated by machine controls from many manufacturers or brands, via digital inputs and outputs over Industrial Ethernet.

Bus-Interfaces:

- » ProfiNet / ProfiDrive
- » EtherCat, SoE, CoE
- » Ethernet IP
- » PowerLink
- » Sercos III

PROCESS AND SENSOR INTERFACES

Fast process interfaces for direct processing of sensor signals are available as freely programmable analog and digital inputs, a fast trigger input, and a capture input.

The safety IO's on Servo Drives with the -1S option with industrial ETHERNET allows safe torque off (STO) of the drives via control signals, without interrupting the power supply.

Drives with -0S option comes without safety IO's and is easier to wire in applications without safety needs.

LOGIC AND POWER SUPPLY

The servo drives have two separate inputs for the logic and motor elements.

This has the advantage that the drive and linear motor do not need to be reinitialized when the machine is restarted, since all process data, including the actual position of the linear motor, is still up to date.

System Integration

Flexible hardware enables control of many 1/2/3-phase motors. Thus, low-power rotary servomotors, such as brushless DC motors, can be integrated in the same control concept.

Additionally, the drives can be equipped with optional peripherals, such as reference and end stop switches, high-precision external position sensors, or a mechanical holding brake.

Series C1200 servo drives have analog and digital inputs and outputs, serial interfaces, fieldbusses, and Ethernet. The user therefore is not dependent on the selection of the overlaid controller. An appropriate interface is available, with associated protocols, for many PLC or IPC solutions.

With flexibility and a compact form factor, LinMot Series C1200 servo drives provide a complete solution for a flexible drive concept in single and multiple axes applications, with linear motors and other actuators.

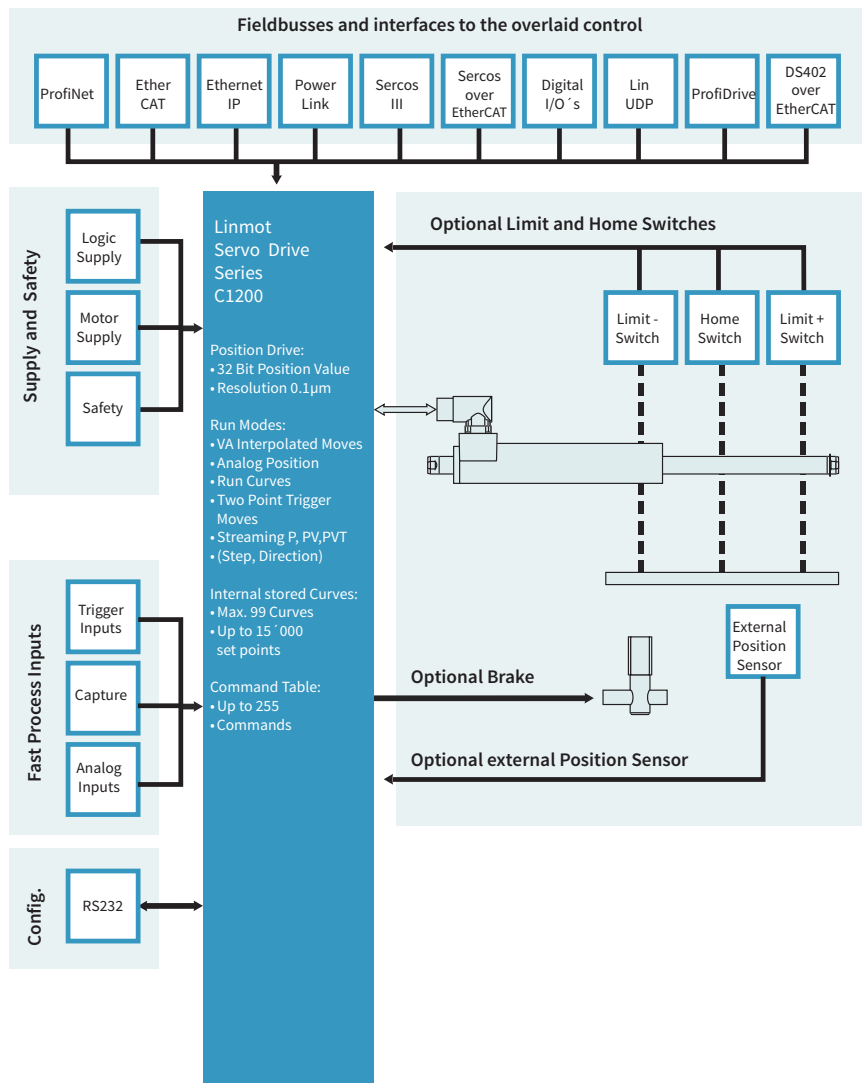

HIGH-END AND NC-MOTIONS MOTOR INTERFACES CONFIGURATION

The ultra-fast control cycle together with the high resolution A/D converters of the C1200 series drives guarantee perfect motor control for demanding Positioning tasks.

The various drive profiles available on the series C1200 drives makes it easy to integrate these drives into systems with synchronized axes and overlaid NC-position controllers with industrial Ethernet communication.

C1200 servo drives provide all necessary interfaces to operate linear or rotary motors with optional external peripherals, such as end position and reference switches, a mechanical brake, or a high-resolution external position sensor.

LinMot Talk, a user-friendly PC software is available for configuration. In addition to online documentation, LinMot Talk provides extensive debugging tools, such as an oscilloscope and an error inspector, for simple and rapid start-up of the Axis.

Fieldbus and Ethernet drives can also be configured directly by the overlaid control, by downloading the configuration parameters via Bus/Ethernet

INTERPOLATED MOVES

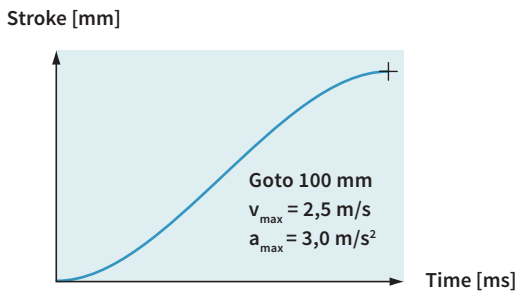

For direct position targets, using absolute or relative positioning, the desired position is reached using acceleration and velocity-limited motion profiles or jerk optimized profiles (example: Besthorn). Positioning commands can be invoked via serial Ethernet or a trigger input.

Stroke range:	±100 m
Position Resolution:	0.1 µm (32Bit)
Velocity Resolution:	1.0 µm/s (32Bit)
Acceleration Resol.:	10.0 µm/s ² (32Bit)

TIME CURVES

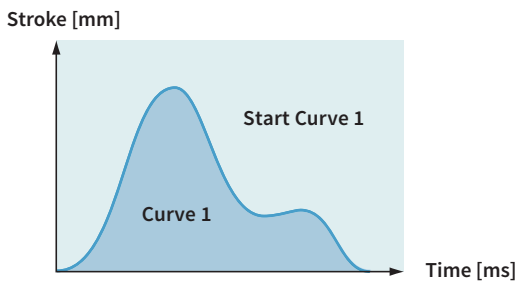

Up to 100 different time curves can be stored on Series C1200 drives, with up to 16,000 individual waypoints. The motor can thus travel along time curves of any complexity, such as those generated by CAD programs and stored in the drive (Excel CSV format). The time curves can be invoked via the serial interface, fieldbusses, Ethernet, or the trigger input.

Stroke range:	±100m
Position Resolution:	0.1 µm (32Bit)
Motion profiles:	Max. 100 Time Curves
Curve points:	Max. 16'000 points

PROFILED MOVES

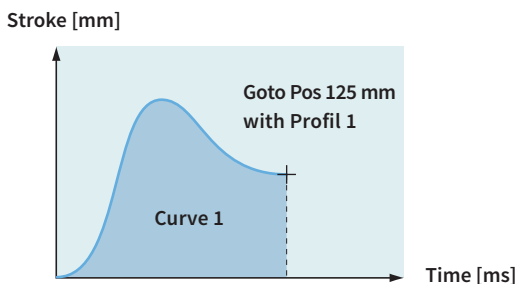

For travel to an absolute position, or shifting by a relative position, any desired motion rules can be stored besides the VA interpolator. They are stored in the drive as motion profiles (Excel CSV format). The positions can be approached, for example, with a sinusoidal motion to optimize power loss, or special reverse optimized motion profiles.

Stroke range:	±100m
Position Resolution:	0.1 µm (32Bit)
Motion profiles:	Max. 100 Time Curves
Curve points:	Max. 16'000 points

SETPOINT STREAMING

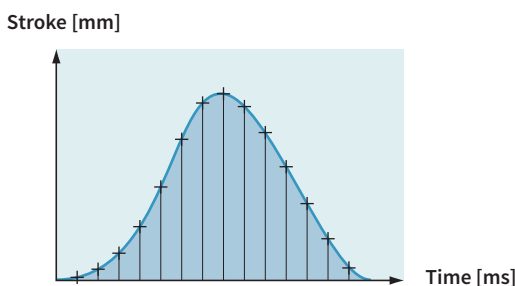

Overlaid NC drives with fieldbus or Ethernet interfaces communicate with the servo drives via "Position Streaming". The position and velocity calculated in the overlaid control is transmitted to the Servo Drive cyclically. The P, PV, or PVA mode is available for this transmission.

Position Resolution:	32 Bit
Velocity Resolution:	32 Bit
Interpolator:	8 kHz
Cycle times:	0.25 - 5 ms

EASY STEPS

Input 1	Pos 125 mm
Input 2	Pos 250 mm
Input 3	Curve 1
Input 4	Pos -30 mm

With the Easy Steps function, up to 4 positions or independent travel commands can be stored on the drive, and addressed via 4 digital inputs or fieldbus interfaces/Ethernet.

Digital inputs: 4
Interface: X4
Scanning rate: 250 µsec

COMMAND TABLE

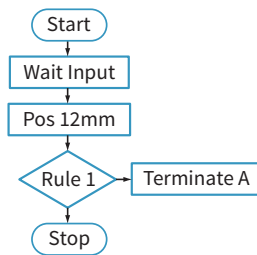

Entire motion sequences with up to 255 individual motion commands can be stored in the Command Table. This is primarily advantageous if complete motion sequences need to be executed very quickly, without dead time from the overlaid PLC. In the Command Table, the programmer has access to all motion commands, internal parameters, and digital inputs and outputs.

Commands: max. 255
Cycle time: 125 µsec

ANALOG POSITION

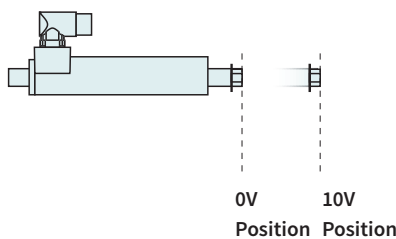

For an analog position target, the linear motor travels to a position proportional to the input voltage. The position is either scanned continuously, or only after a rising edge of the trigger signal. In order to prevent uncontrolled jumps in position, the motor travels to the positions with a programmable maximum acceleration and velocity (VA interpolator).

Inputs: Analog Input X4
Voltage range: 0-10VDC or ±10V
Resolution: 12 Bit
Scanning rate: >=125 µsec (adjustable)

EASY STEPS PARAMETER SCALE

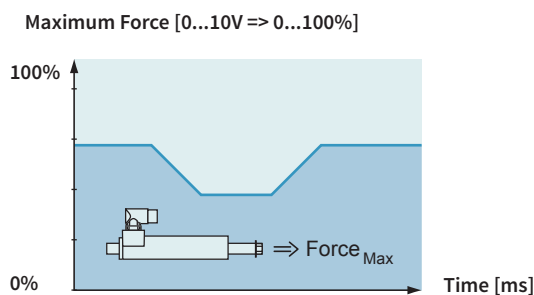

Easy Steps provide the ability to parameterize internal parameters using two analog inputs. If, for example, the maximum motor current is read at an analog input, then the maximum motor force can be provided as analog for freely programmable joining processes.

Inputs: 2 x Analog
Voltage range: 0-10VDC
Resolution: 12 Bit
Scanning rate: 250 µsec

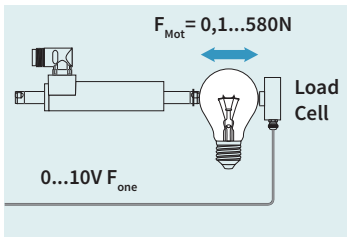
CLOSED LOOP FORCE CONTROL

Using the force control technology function, precise joining processes can be implemented reliably and reproducibly with high-precision force control. For force control, the current motor force is measured with a load cell and controlled in the drive. Joining process or quality checks with high requirements for applied force can be implemented.

Analog input:	0-10V or $\pm 10V$
Resolution:	12 Bit
Min. Force Resolution:	0.1N

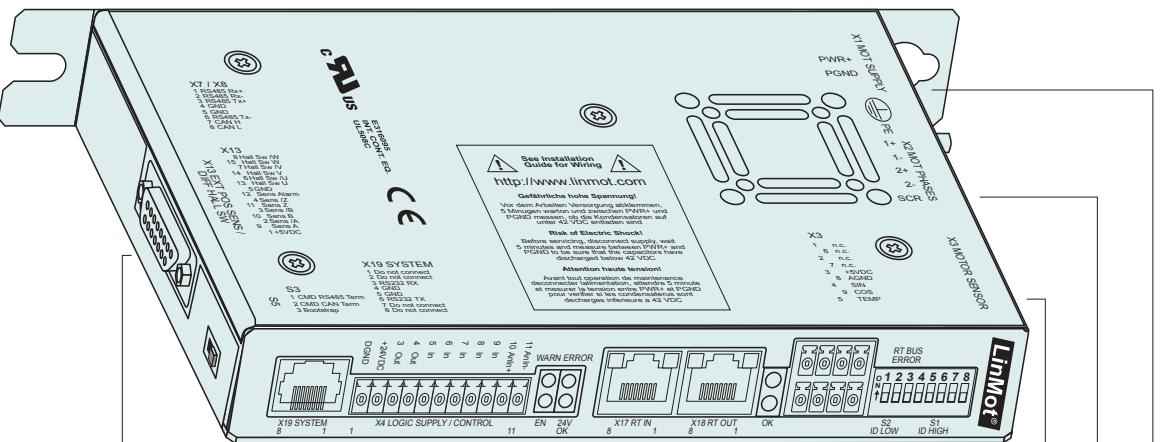

- X1: Motor Supply
- X2: Motor Phases
- X3: Motor Signal
- S1-2: Bus Address
- X33: STO Relais (only for 1S option)
- LED: RT Bus
- X17: RT ETH In
- X18: RT ETH Out
- LED: State Indicator
- X4: Logic Supply / Control
- X19: System Configuration RS232
- X13: External Position Sensor
Differential Hall Switch

Interfaces	C1250-PN-XC	C1250-PD-XC	C1250-EG-XC	C1250-DS-XC	C1250-SE-XC	C1250-IP-XC	C1250-PL-XC	C1250-SC-XC	C1250-LU-XC
PROFINET	•								
PROFINET ProfDrive		•							
ETHERCAT				•					
ETHERCAT CIA402					•				
ETHERCAT SOE						•			
ETHERNET IP						•			
POWERLINK							•		
SERCOS III								•	
LinUDP									•



- C1250-PN-XC
- C1250-EC-XC
- C1250-IP-XC
- C1250-PL-XC
- C1250-SC-XC
- C1250-SE-XC
- C1250-PD-XC
- C1250-DS-XC
- C1250-LU-XC

- » Absolute & Relative Positioning
- » Time based motion profiles
- » Internally stored Motion Sequences
- » Position Streaming
- » Analog Position Target
- » Analog Parameter Scaling
- » Force Control Technology Function
- » Customer-Specific Functions

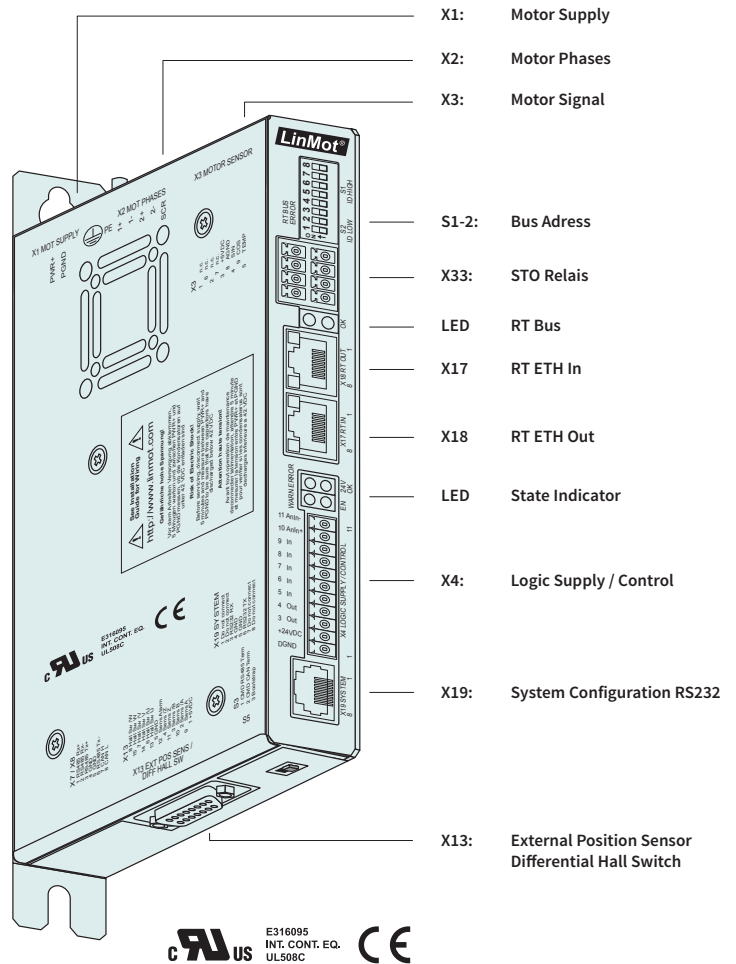

INDUSTRIAL ETHERNET

Series C1200 drives allow integration of LinMot linear motors in controls concepts with industrial Ethernet interfaces. The user can integrate Series C1200 drives regardless of the provider of the overlaid control.

LinMot drives are available with common industrial Ethernet protocols. Since all Ethernet drives have the same motion command interface, and the control and status word are identical, software blocks that have been implemented once can be transferred to other drives without a problem.

The series C1200 servo drives support the following industrial Ethernet protocols:

- » Profinet
- » EtherCAT
- » Ethernet IP
- » PowerLink
- » Sercos III
- » Sercos over EtherCAT
- » ProfiDrive
- » CiA 402
- » LinUDP

The appropriate drive is available for each protocol.

TECHNICAL DATA

Type:	Realtime ETHERNET
Switch/Hub:	Integrated 2-Port Hub/Switch
Transfer rate:	10/100MBit/sec
Minimal cycle times:	
Bus cycle:	250 µs
IO update:	250 µs
Trigger Input:	125 µs
Position control loop:	125 µs
Current control loop:	62.5 µs

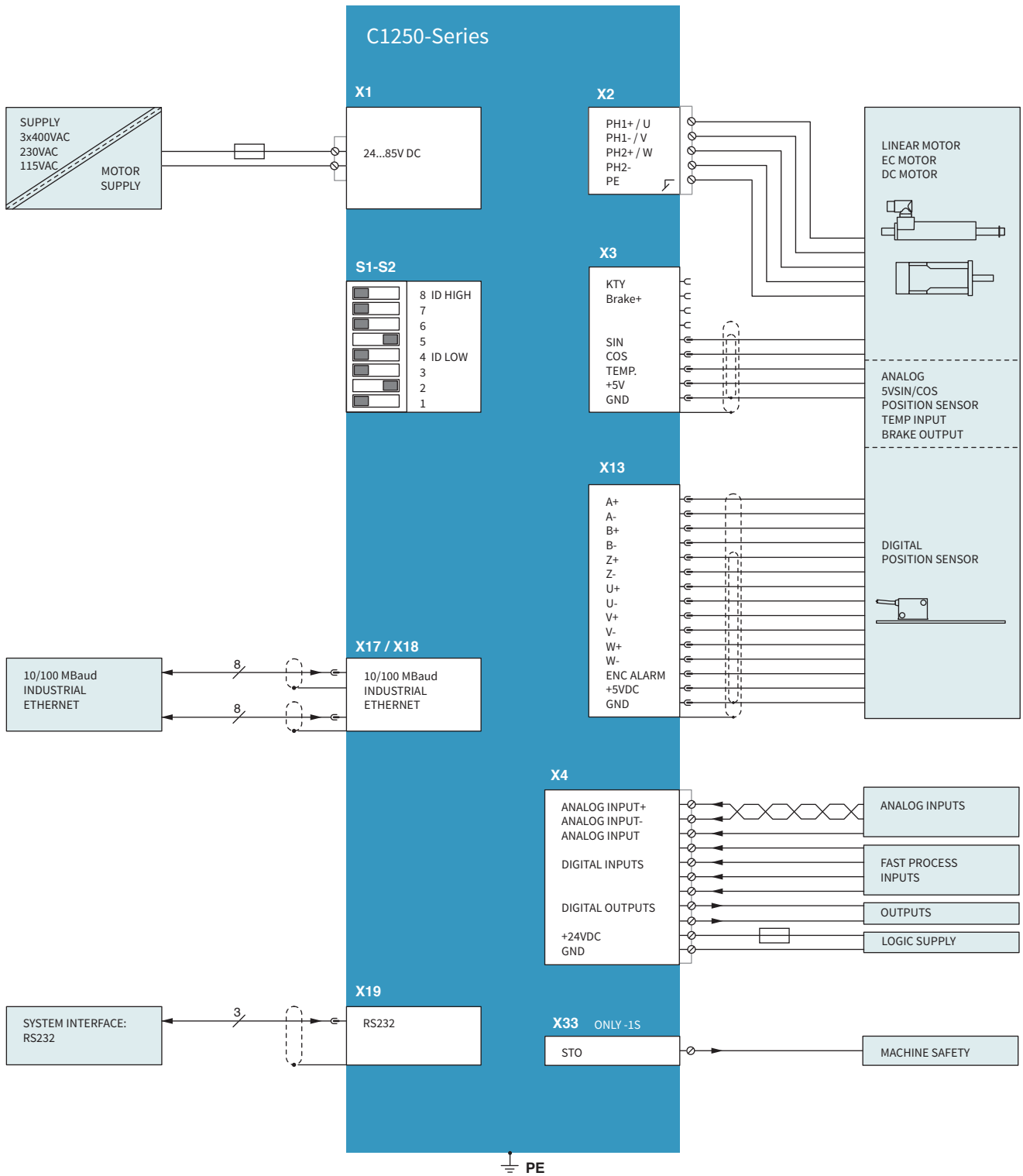

X1 + PE MOTOR SUPPLY / REGENERATION RESISTOR

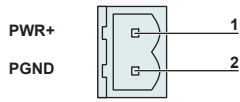

Connector has to be ordered separately

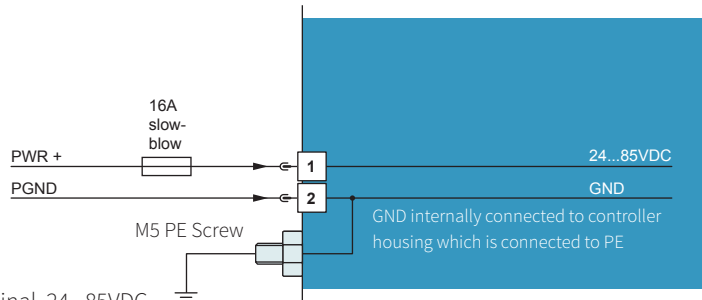

Motor Supply: 72VDC nominal, 24...85VDC
 Absolute max. Rating: 72VDC +20%.
 External Fuse: 16A slow-blow / min. 100VDC
 If motor supply voltage exceeds 90VDC, the drive will go into error state.

- » Use 60/75°C copper conductors only
- » Conductor Cross-Section 2.5mm² (AWG14) max Length 3 m

X2 MOTOR PHASES

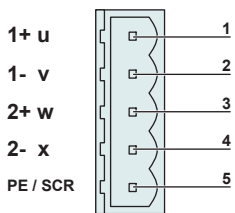

Connector has to be ordered separately

Nr	Designation	LinMot Linear Motor	Color	3-Phase EC-Motor	Color
1	PH1+	Motor Phase 1+	red	Motor Phase U	red
2	PH1-	Motor Phase 1-	pink	Motor Phase V	pink
3	PH2+	Motor Phase 2+	blue	Motor Phase W	blue
4	PH2-	Motor Phase 2-	grey	Motor Phase X	grey
5	PE/SCR	Shield		Shield	

- » Use 60/75°C copper conductors only
- » Conductor cross-section: 0.5 – 2.5mm² (depends on Motor current) / AWG 21 -14

X3 MOTOR SENSOR / BRAKE

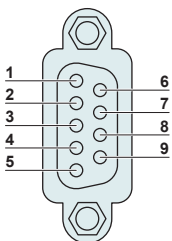

DSUB-9

Nr		LinMot Motor	EC Motor
1		Do not connect	Do not connect
	6	Brake+	Brake+
2		Do not connect	Do not connect
	7	Do not connect	KTY
3		+5VDC	+5VDC
	8	AGND	AGND
4		Sensor Sine	Sensor Sine / Hall Switch U
	9	Sensor Cosine	Sensor Cosine / Hall Switch V
5		Temp In	Hall Switch W
	Case	Shield	Shield

- » Use +5V (X3.3) and AGND (X3.8) only for motor internal hall sensor supply (max. 100mA)
- » Cable length < 30 m
- » Brake+: 24V / max. 500mA, Peak 1.4mA (will shut down if exceeded)
- » Caution: Do NOT connect AGND (X3.8) to ground or earth!

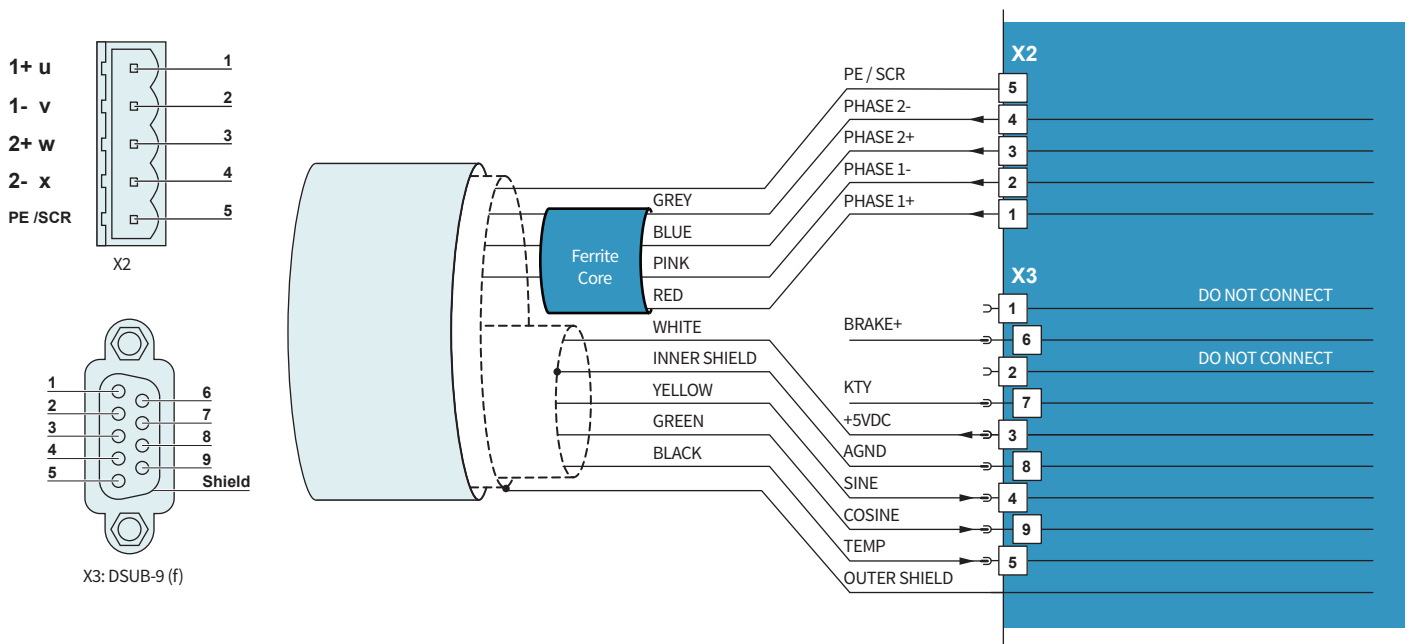

Use Y-style motor cables only (for example K15-Y/C)!
A W-style cable has a different shielding, so it cannot be modified to a Y-style cable!

X4 LOGIC SUPPLY / IO CONNECTION

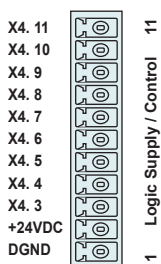

DSUB-9 (f)
Spring cage connector
(has to be ordered separately)

Nr			
11	AnIn-	X4.11	Configurable Analog Input differential (with X4.10)
10	AnIn+	X4.10	Configurable Analog Input differential (with X4.11)
9	AnIn	X4.9	Configurable Analog Input single ended
8	In	X4.8	Configurable Input
7	In	X4.7	Configurable Input
6	In	X4.6	Configurable Input
5	In	X4.5	Configurable Input
4	Out	X4.4	Configurable Output
3	Out	X4.3	Configurable Output
2	+24VDC	Supply	Logic Supply 22-26 VDC
1	GND	Supply	Ground

Inputs: (X4.5...X4.8)
Outputs: (X4.3 & 4.4)
Analog inputs:
X4.9:
X4.10/X4.11:

Supply 24V:

24V / 5mA (Low Level: -0.5 to 5VDC, High Level: 15 to 30VDC)
24V / max. 500mA, Peak 1.4mA (will shut down if exceeded)
12 bit A/D converted.
Single ended analog input to GND, 0..10V, Input Resistance: 51kΩ to GND
Differential analog input, +/- 10V. Common mode range: +/- 5VDC to GND.
Input Resistance: 11.4kΩ for each signal to GND
typically 500mA / max. 2.5A (if all outputs "on" with max. load.)
» Use 60/75°C copper conductors only
» Conductor cross-section max. 1.5 mm²
» Stripping length: 10 mm
» The 24VDC supply for the control circuit (X4.2) must be protected with an external fuse (3A slow blow)

X13 EXTERNAL POSITION SENSOR PIN CONFIGURATION

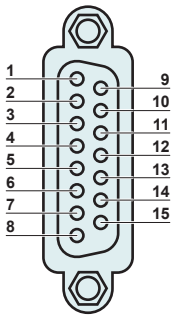

DSUB-15 (f)

Nr	ABZ with Hall Switches	SSI / BiSS / EnDat
1	+5V DC	+5V DC
9	A+	A+
2	A-	A-
10	B+	B+
3	B-	B-
11	Z+	Data+
4	Z-	Data-
12	Encoder Alarm	Encoder Alarm
5	GND	GND
13	U+	nc
6	U-	nc
14	V+	nc
7	V-	nc
15	W+	Clk+
8	W-	Clk-
Case	Shield	Shield

Position Encoder Inputs (RS422):

Max. counting frequency: 25 M counts/s with quadrature decoding. A minimum of 40ns edge separation must be guaranteed by the encoder under any circumstances! The maximal frequency of each signal is 6.25 MHz.

Differential Hall Switch Inputs (RS422):

Input Frequency: <1kHz

Enc. Alarm In:

5V / 1mA

Sensor Supply:

5VDC, max 100mA

X17 - X18 REALTIME ETHERNET 10/100 MBIT/S

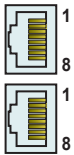

RJ-45

Nr		
X17	RT ETH In	Specification depends on RT-Bus Type. Please refer to interface documentation.
X18	RT ETH Out	

X19 SYSTEM

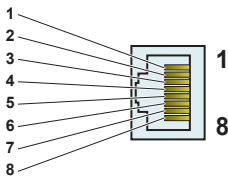

RJ-45

Nr	
1	(do not connect)
2	(do not connect)
3	RS232 RX
4	GND
5	GND
6	RS232 TX
7	(do not connect)
8	(do not connect)
case	Shield

Use isolated USB-RS232 converter (Art.-No. 0150-2473) for configuration over RS232

X33 SAFETY RELAYS (ONLY FOR -1S)

X33. 4/8 Ksr+
 X33. 3/7 Ksr-
 X33. 2/6 Ksr f+
 X33. 1/5 Ksr f-

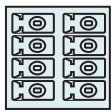

X33 STO RELAYS

Spring cage connector

Nr		
4 / 8	Ksr +	Safety Relay 1 / 2 Input positive
3 / 7	Ksr -	Safety Relay 1 / 2 Input negative
2 / 6	Ksr f+	Safety Relay 1 / 2 feedback positive
1 / 5	Ksr f-	Safety Relay 1 / 2 feedback negative



- » Use 60/75°C copper conductors only
- » Conductor cross-section max. 1.5 mm²
- » Stripping length: 10 mm
- » Never connect the safety relays to the logic supply of the drive!

S1 - S2 ADDRESS SELECTORS



S1 (5...8)	Bus ID High (0 ... F). Bit 5 is the LSB, bit 8 the MSB.
S2 (1...4)	Bus ID Low (0 ... F). Bit 1 is the LSB, bit 4 the MSB

Setting the ID high & low to FF resets the drive to manufacturer settings!

The use of these switches depends on the type of fieldbus which is used. Please see the corresponding manual for further information.

S5 BUS TERMINATION



Default position
 View: X13 Connector is left next to S5 switch.

S5	Bootstrap (Internal use only)
----	-------------------------------

LEDS STATE DISPLAY



24VOK	Green	24V Logic Supply OK
En	Yellow	Motor Enabled / Error Code Low Nibble
Warn	Yellow	Warning / Error Code High Nibble
Error	Red	Error

RT BUS LEDES



BUS OK	Green	OK
BUS Error	Red	Error

The use of these LEDs depends on the type of fieldbus which is used. Please see the corresponding manual for further information.

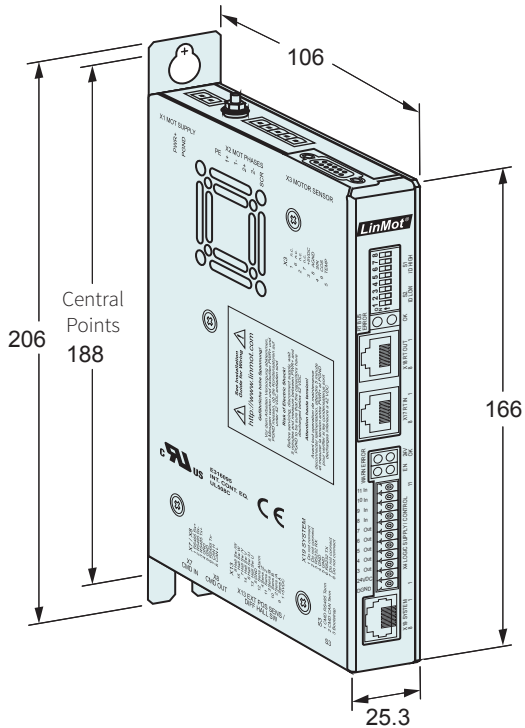

C1250-...-0S

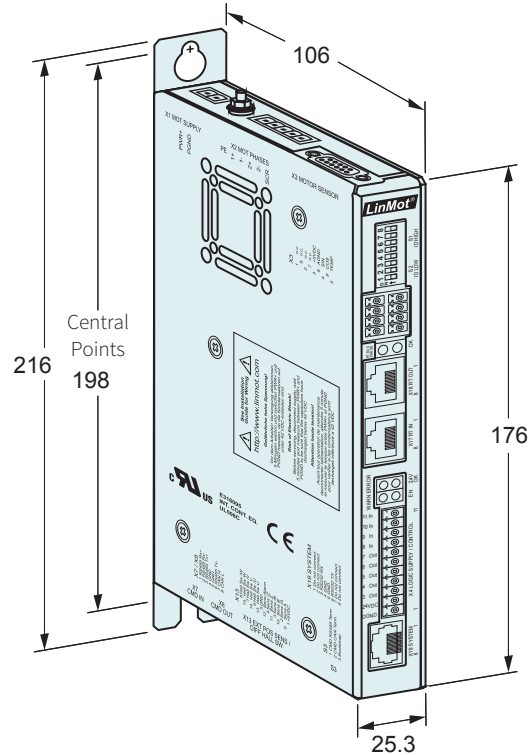

C1250-...-1S

Dimensions in mm
Mounting points for M5 screws

Servo Drive Series		C1250-...-0S	C1250-...-1S
Width	mm (in)	106 (4.2)	106 (4.2)
Height	mm (in)	166 (6.5)	176 (6.9)
Height with fixings	mm (in)	206 (8.1)	216 (8.5)
Depth	mm (in)	25.3 (1.0)	25.3 (1.0)
Weight	g (lb)	630 (1.4)	700 (1.54)
Mounting Screws		2 x M5	2 x M5
Mounting Distance between screw holes	mm (in)	168 (6.61)	188 (7.4)
Case IP Code	IP	20	
Storage temperature	°C	-25...40	
Transport temperature	°C	-25...70	
Operating temperature	°C	0...40 at rated date 40...50 with power derating	
Relative humidity		95% (non-condensing)	
Pollution	IEC/EN 60664-1	Pollution degree 2	
Shock resistance (16 ms)	-1S option		3.5g
Vibration resistance (10-200Hz)	-1S option		1g
Max. case temperature	°C	70	
Max. power dissipation	W	30	
Mounting place		in the control cabinet	
Mounting position		vertical	
Distance between Drives	mm (in)	Without Power Derating: 20 (0.8) left/right / 50 (2) top/bottom With Power Derating: 5 (0.2) left/right / 20 (0.8) top/bottom	

Servo Drives		
Item	Description	Part Number
C1250-PN-XC-0S-000	ProfiNet Drive (72V/25A)	0150-1888
C1250-PD-XC-0S-000	ProfiNet ProfiDrive (72V/25A)	0150-2618
C1250-EC-XC-0S-000	EtherCAT Drive (72V/25A)	0150-1884
C1250-DS-XC-0S-000	EtherCAT CoE Drive (72V/25A)	0150-2415
C1250-SE-XC-0S-000	EtherCAT SoE Drive (72V/25A)	0150-1897
C1250-IP-XC-0S-000	Ethernet/IP Drive (72V/25A)	0150-1886
C1250-PL-XC-0S-000	Powerlink Drive (72V/25A)	0150-1885
C1250-SC-XC-0S-000	Sercos III Drive (72V/25A)	0150-1887
C1250-LU-XC-0S-000	ETHERNET LinUDP Drive (72V/25A)	0150-2491
C1250-PN-XC-1S-000	Profinet Drive (72V/25A), STO	0150-2348
C1250-PD-XC-1S-000	ProfiNet ProfiDrive (72V/25A), STO	0150-2619
C1250-EC-XC-1S-000	EtherCAT Drive (72V/25A), STO	0150-2345
C1250-DS-XC-1S-000	EtherCAT CoE Drive (72V/25A), STO	0150-2416
C1250-SE-XC-1S-000	EtherCAT SoE Drive (72V/25A), STO	0150-2350
C1250-IP-XC-1S-000	Ethernet/IP Drive (72V/25A), STO	0150-2346
C1250-PL-XC-1S-000	Powerlink Drive (72V/25A), STO	0150-2347
C1250-SC-XC-1S-000	Sercos III Drive (72V/25A), STO	0150-2349
C1250-LU-XC-1S-000	ETHERNET LinUDP Drive (72V/25A), STO	0150-2492

Accessories		
Item	Description	Part Number
DC01-CX000-0S/X1/X4	Connector set C1250-...-0S (X1, X4)	0150-3527
DC01-CX000-1S/X1/X4/X33	Connector set C1250-...-1S (X1, X4, X33)	0150-3528
DC01-C1X00/X1	Drive Connector for PWR 72DC Input	0150-3525
DC01-CX000-X2	Motor connector (X2)	0150-3526
DC01-Signal/X4	Drive Connector 24VDC & Logic	0150-3447
DC01-Safety/X33	Drive Connector Safety	0150-3451

A series of horizontal dotted lines spanning the width of the page, intended for taking notes.

SERIES E1200



- ✓ Absolute / relative positioning commands
- ✓ Limited jerk motion commands
- ✓ Time Curves
- ✓ Real Time (Streaming)
- ✓ Synchronous control (Drive profiles)
- ✓ Master Encoder Synchronization (In/Out)
- ✓ PLC or Stand-Alone Solutions
- ✓ Industrial Ethernet Configuration / Remote Access Ethernet
- ✓ Digital and Analog IO's
- ✓ Interface for optional incremental and absolute sensor
- ✓ Position Encoder Simulation (RS 422)
- ✓ Master / Slave Solutions
- ✓ ± 10 VDC Force / Speed Control
- ✓ Supports Plug and Play
- ✓ CE

Servo Drive E1200

Series E1200 Servo Drives are modular axis drives, with 32-bit position resolution and an integrated power stage, for linear and rotary motors.

The drives are suitable for simplest, standard, and high-end positioning tasks, across the entire force range of the LinMot product range.



CONNECTION TO MACHINE DRIVE

The Series E1200 Servo Drives can be actuated by machine controls from many manufacturers or brands, via digital inputs and outputs, RS232 or RS485 serial interface, CanBus CANopen and DeviceNet interfaces, Profibus DP, or industrial ETHERNET.

PROCESS AND SAFETY INTERFACES

Fast process interfaces for direct processing of sensor signals are available as freely programmable analog and digital inputs, a fast trigger input, and a capture input.

The safe pulse inhibitor on Servo Drive with fieldbus interfaces or industrial ETHERNET allows safe stop of the drives via control signals, per EN 954-1, without interrupting the power supply.

LOGIC AND POWER SUPPLY

The Servo Drives have two separate power supply inputs for the logic and power elements.

In an E-stop and safe stop of the drive, only the power element supply is cut off from the drive. The logic supply and the drive continue to run.

This has the advantage that the drive and linear motor do not need to be reinitialized when the machine is restarted, since all process data, including the current position of the linear motor, are still up to date.

System Integration

Flexible hardware enables control of many 1/2/3- phase motors. Thus, low-power rotary servomotors, such as brushless DC motors, can be integrated in the same controls concept.

Additionally, the drives can be equipped with optional peripherals, such as reference and end stop switches, high-precision external position sensors, or a mechanical holding brake.

Series E1200 Servo Drives have analog and digital inputs and outputs, serial interfaces, fieldbusses, and ETHERNET connections. The user is therefore not dependent on the selection of the overlaid drive. An appropriate interface is available, with associated protocols, for any PLC or IPC solution.

With flexibility and a compact form factor, LinMot Series E1200 Servo Drives provide a complete solution for a flexible drive concept in single and multiple axes applications, with linear motors and other actuators.

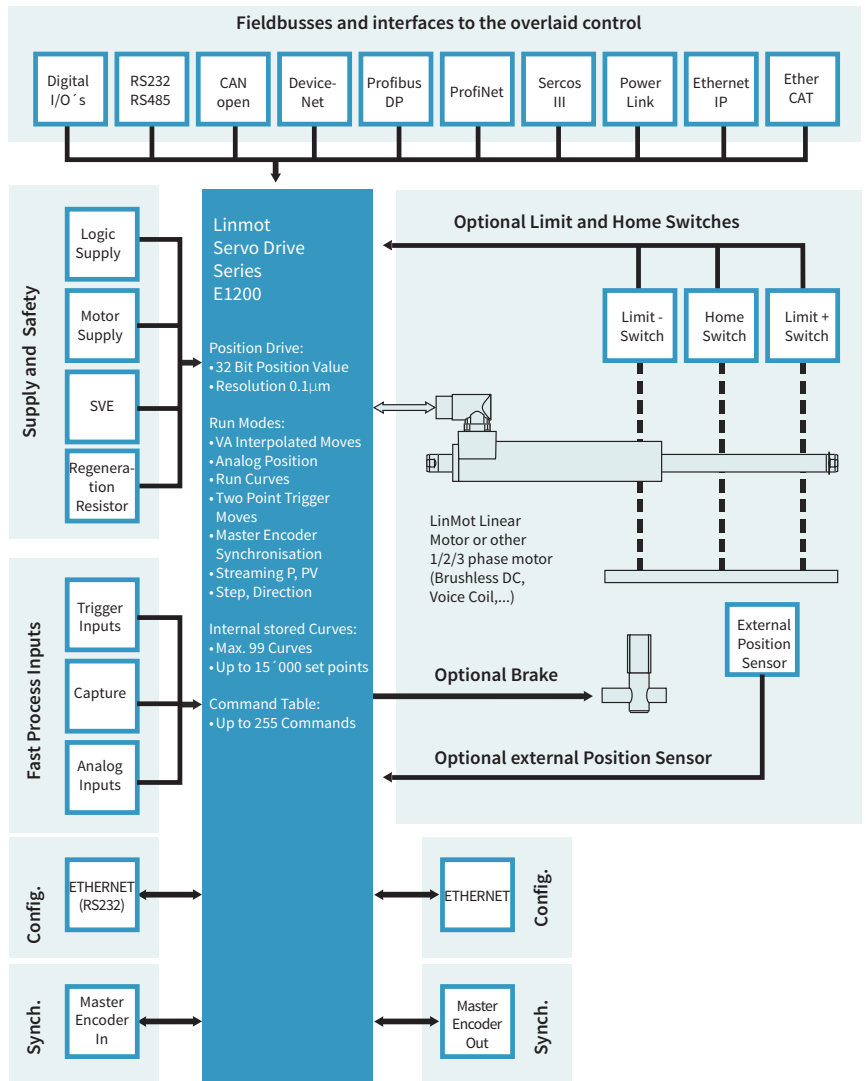

MASTER ENCODER

For synchronization to a mechanical master shaft, or a rotating main drive, the Axis (linear motors and rotary motors) can be coupled to an electronic main shaft via the Master Encoder Interface.

The encoder signal from the main shaft can be passed through by the Master Encoder Interface, so that any number of linear motors can be synchronized to the main shaft.

MOTOR INTERFACES

E1200 Servo Drives provide all necessary interfaces to operate linear or rotary motors with optional external peripherals, such as end position and reference switches, a mechanical brake, or a high-resolution external position sensor.

In special applications, two drives can be synchronized with each other using the synchronization interface in master booster mode.

CONFIGURATION

Parameterization and configuration of the Servo Drive is done via the Ethernet interface on the front side for simultaneous configuration of several drives.

LinMot Talk user-friendly PC software is available for configuration. In addition to online documentation, LinMot Talk provides extensive debugging tools, such as an oscilloscope and an error inspector, for simple and rapid start-up of the Axis.

Fieldbus and ETHERNET drives can also be configured directly by the overlaid control.

INTERPOLATED MOVES

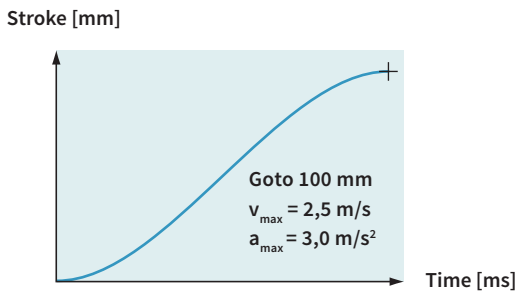

For direct position targets, using absolute or relative positioning, the desired position is reached using acceleration and velocity-limited motion profiles or jerk optimized profiles (jerk limited and Bestehorn). Positioning commands can be invoked via the serial interfaces, CANopen, DeviceNet, Profibus, Ethernet or a trigger input.

Stroke range:	±100 m
Position Resolution:	0.1 µm (32Bit)
Velocity Resolution:	1.0 µm/s (32Bit)
Acceleration Resol.:	10.0 µm/s ² (32Bit)

TIME CURVES

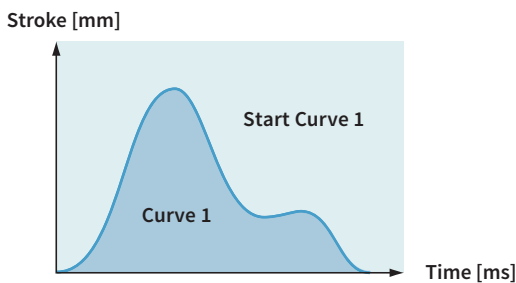

Up to 100 different time curves can be stored Series E1200 drives, with up to 16,000 individual waypoints. The motor can thus travel along time curves of any complexity, such as those generated by CAD programs and stored in the drive (Excel CSV format). The time curves can be invoked via the serial interface, fieldbuses, ETHERNET, or the trigger input.

Stroke range:	±100m
Position Resolution:	0.1 µm (32Bit)
Motion profiles:	Max. 100 Time Curves
Curve points:	Max. 16'000 points

PROFILED MOVES

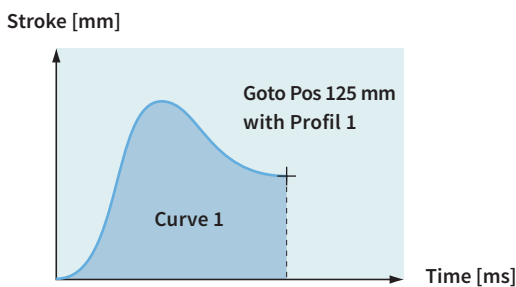

For travel to an absolute position, or shifting by a relative position, any desired motion rules can be stored besides the VA interpolator. They are stored in the drive as motion profiles (Excel CSV format). The positions can be approached, for example, with a sinusoidal motion to optimize power loss, or special reverse optimized motion profiles.

Stroke range:	±100m
Position Resolution:	0.1 µm (32Bit)
Motion profiles:	Max. 100 Time Curves
Curve points:	Max. 16'000 points

SETPOINT STREAMING

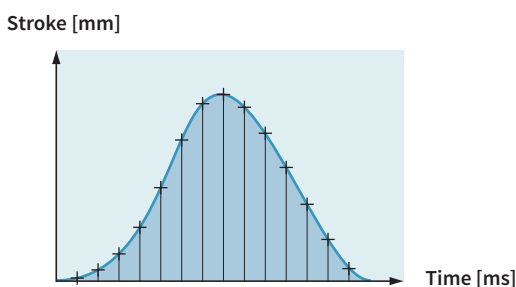

Overlaid NC drives with fieldbus or ETHERNET interfaces communicate with the Servo Drives via "Position Streaming". The position and velocity calculated in the overlaid control is transmitted to the Servo Drive cyclically. The P, PV, or PVT mode is available for this transmission.

Position Resolution:	32 Bit
Velocity Resolution:	32 Bit
Interpolator:	10 kHz
Cycle times:	0.4 - 5 ms

EASY STEPS

Input 1	Pos 125 mm
Input 2	Pos 250 mm
Input 3	Curve 1
Input 4	Pos -30 mm
Input 5	Pos +12,5 mm
Input 6	Curve 2
Input 7	Pos 2 mm
Input 8	Pos -12,5 mm

With the Easy Steps function, up to 8 positions or independent travel commands can be stored on the drive, and addressed via 8 digital inputs or fieldbus interfaces/ETHERNET.

Digital inputs: max. 8
Interface: X4
Scanning rate: 200 µsec

COMMAND TABLE

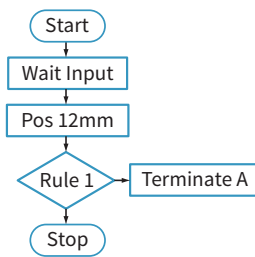

Entire motion sequences with up to 255 individual motion commands can be stored in the Command Table. This is primarily advantageous if complete motion sequences need to be executed very quickly, without dead time from the overlaid drive. In the Command Table, the programmer has access to all motion commands, internal parameters, and digital inputs and outputs.

Commands: max. 255
Cycle time: 100 µsec

MASTER ENCODER SYNCHRONIZATION (MT)

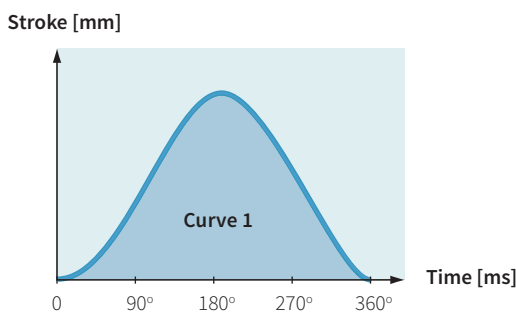

For synchronization to an external main or master shaft, the linear motor travels along the motion profiles stored in the drive, at the machine speed (machine angle 0...360°). Using this function, mechanical cam discs can be replaced with highly dynamic linear motors. The motion profiles can be freely defined, and the correct motion profile can be invoked during product changeover with no changeover time.

Motion profiles: Max. 100 curve profiles
Curve points: Max. 16'000 points
Encoder Counter: 32 Bit
Encoder Input: A/B/Z (RS422)
Max. counting frequency: Max. 4.5 MHz

BELT SYNCHRONIZATION

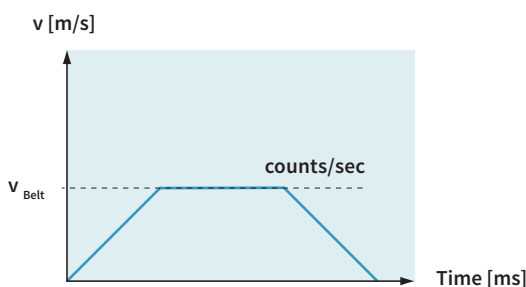

Synchronization to a belt speed can be done using the Master Encoder Interface or Step/Direction/ Zero interface. Applications such as the "flying saw", synchronous loading or unloading, synchronous filling or labeling of bottles or containers on a conveyor belt, and many other applications can be implemented in this way.

Encoder Counter: 32 Bit
Encoder Input: A/B/Z (RS422), max. 5 MHz
 STEP/DIR/ZERO
Max. counting frequency: Max. 4.5 MHz

ANALOG POSITION

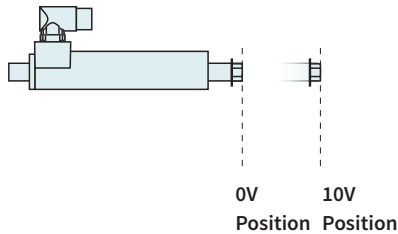

For an analog position target, the linear motor travels to a position proportional to the input voltage. The position is either scanned continuously, or only after a rising edge of the trigger signal. In order to prevent uncontrolled jumps in position, the motor travels to the positions with a programmable maximum acceleration and velocity (VA interpolator).

Inputs:	Analog Input X4 or X20
Voltage range:	0-10VDC or ±10V
Resolution:	12 Bit
Scanning rate:	>=100 µsec (adjustable)

EASY STEPS PARAMETER SCALE

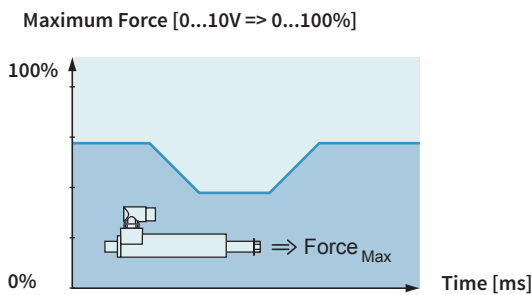

Easy Steps provide the ability to parameterize internal parameters using two analog inputs. If, for example, the maximum motor current is read at an analog input, then the maximum motor force can be provided as analog for freely programmable joining processes.

Inputs:	2 x Analog (X4.4, X4.7)
Voltage range:	0-10VDC
Resolution:	12 Bit
Scanning rate:	200 µsec

CLOSED LOOP FORCE CONTROL

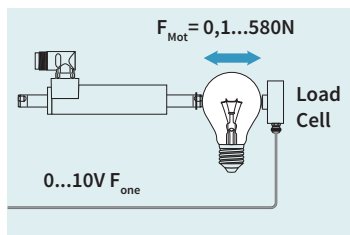

Using the force control technology function, precise joining processes can be implemented reliably and reproducibly with high-precision force control. For force control, the current motor force is measured with a load cell and controlled in the drive. Joining process or quality checks with high requirements for applied force can be implemented.

Analog Input:	0-10V or ±10V
Resolution:	12 Bit
Min. Force Resolution:	0.1N

WINDING APPLICATION

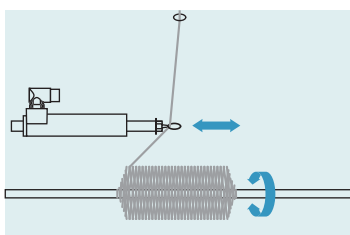

For winding textile yarns, glass fiber optics, or wires, a complete functional block is available that controls the entire sequence of a complete winding process.

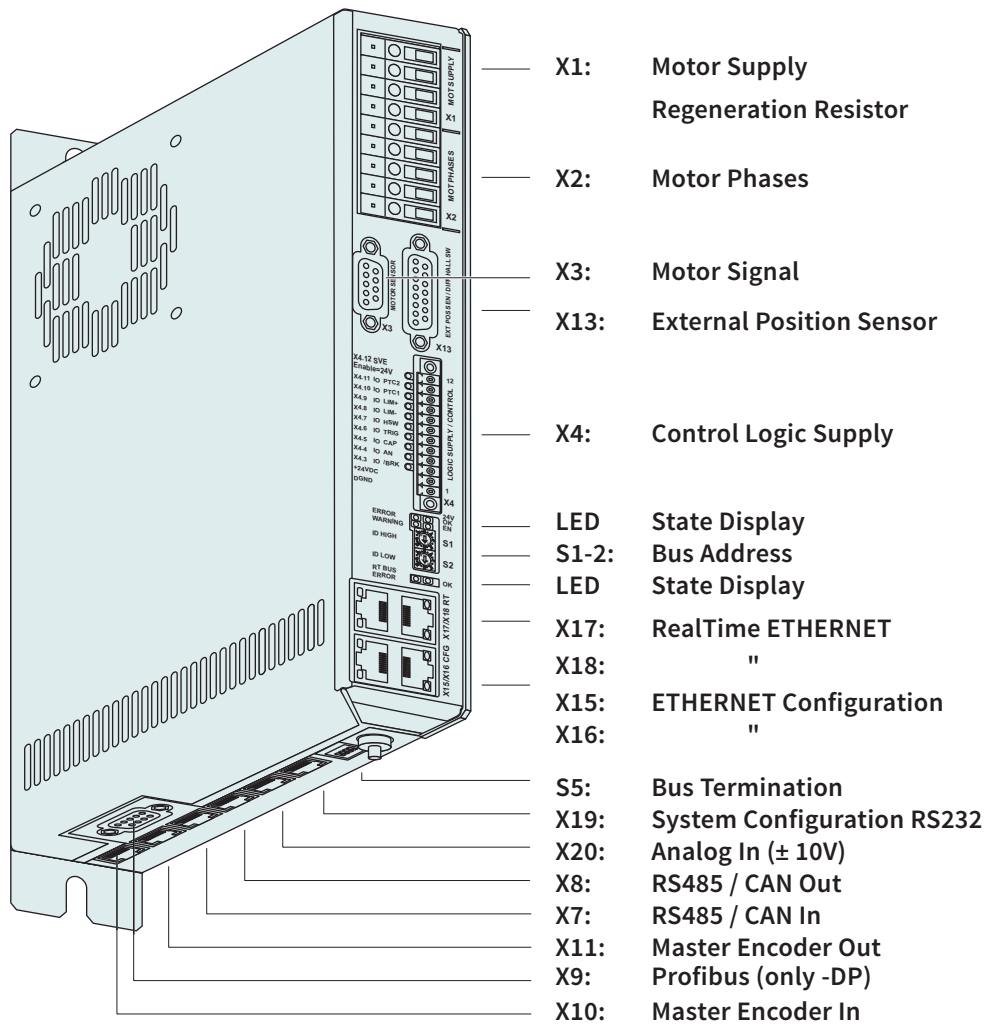

Interfaces	E1250-PL-UC	E1250-PN-UC	E1250-SC-UC	E1250-IP-UC	E1250-LU-UC	E1250-EC-UC	E1250-SE-UC	E1250-DS-UC	E1230-DP-UC	E1200-GP-UC
CANopen										•
LinRS										•
POWERLINK	•									
PROFINET		•								
sercos			•							
sercos over EtherCAT							•			
ETHERNET IP				•						
LinUDP					•					
EtherCAT						•				
ETHERCAT CiA402								•		
PROFIBUS-DP									•	

- E1250-PL-UC**
- E1250-PN-UC**
- E1250-PD-UC**
- E1250-SC-UC**
- E1250-IP-UC**
- E1250-LU-UC**
- E1250-EC-UC**
- E1250-SE-UC**
- E1250-DS-UC**
- E1200-GP-UC**



- » Absolute & Relative Positioning
- » Travel Along Time Curves
- » Positioning using Motion Profiles
- » Internally stored Motion Commands
- » Internally stored Motion Sequences
- » Master Encoder Synchronization
- » Synchronization to Belt Speed
- » Position Streaming
- » Analog Position Target
- » Analog Parameter Scaling
- » Winding Function Block
- » Force Control Technology Function
- » Customer-Specific Functions

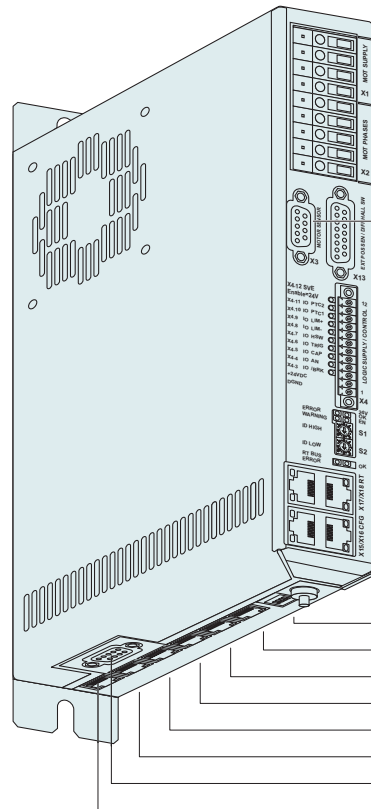

- X1: Motor Supply
Regeneration Resistor
- X2: Motor Phases
- X3: Motor Signal
- X13: External Position Sensor
- X4: Control Logic Supply
- LED State Display
- S1-2: Bus Address
- LED State Display
- X17: RealTime ETHERNET
- X18: "
- X15: ETHERNET Configuration
- X16: "
- S5: Bus Termination
- X19: System Configuration RS232
- X20: Analog In (± 10V)
- X8: RS485 / CAN Out
- X7: RS485 / CAN In
- X11: Master Encoder Out
- X9: Profibus (only -DP)
- X10: Master Encoder In

INDUSTRIAL ETHERNET

Series E1200 drives allow integration of LinMot linear motors in controls concepts with industrial ETHERNET interfaces. The user can integrate Series E1200 drives regardless of the provider of the overlaid control.

LinMot drives are available with common industrial ETHERNET protocols. Since all ETHERNET drives have the same motion command interface, and the control and status word are identical, software blocks that have been implemented once can be transferred to other drives without a problem.

TECHNICAL DATA

Series E1200 Servo Drives support the following industrial ETHERNET protocols:

- » Profinet
- » ETHERNET IP
- » PowerLink
- » EtherCat
- » Sercos III

The appropriate drive is available for each protocol.

TECHNICAL DATA

Type: Realtime ETHERNET
 Switch/Hub: Integrated 2-Port Hub/Switch
 Transfer rate: 10/100MBit/sec

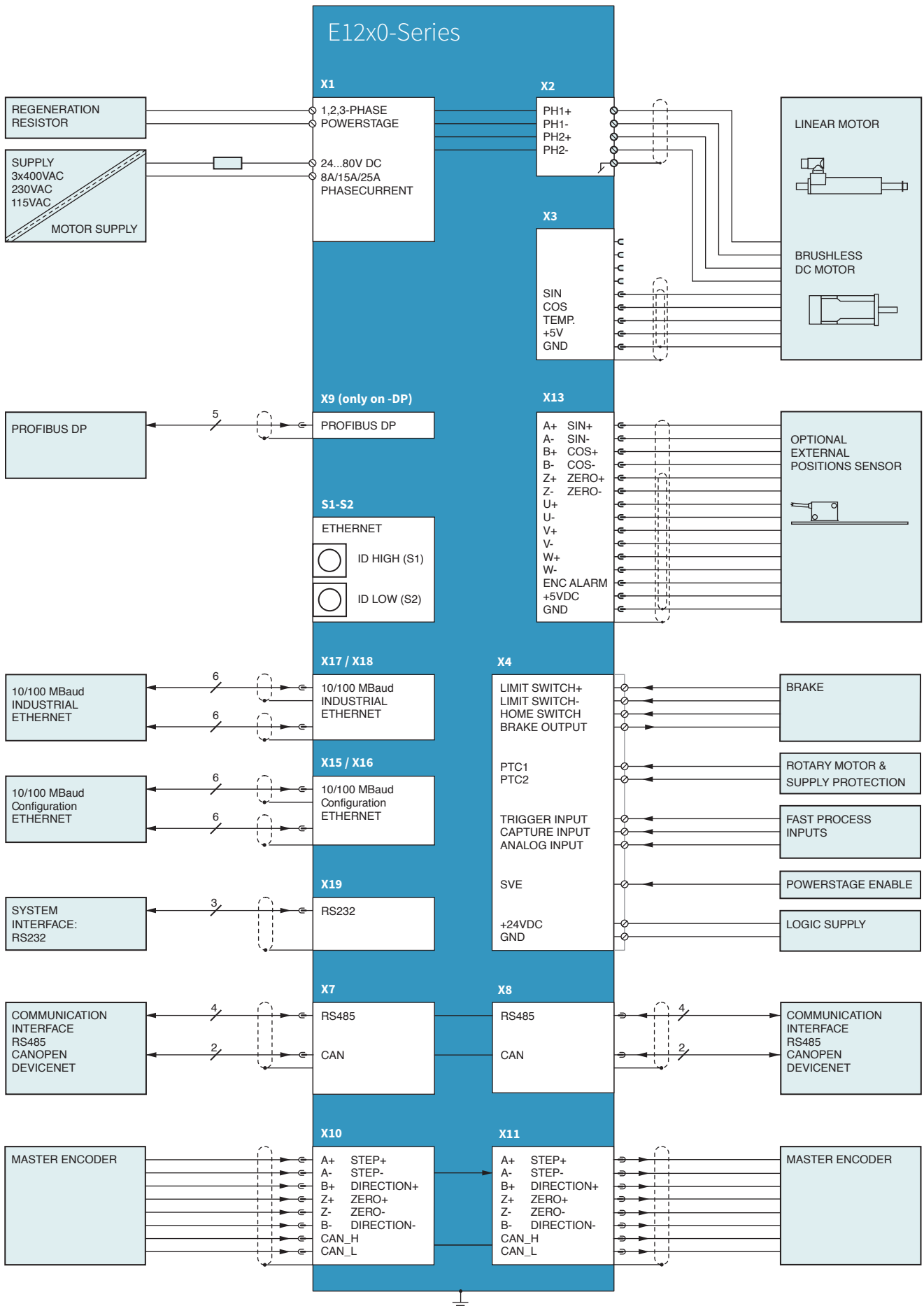

X1 MOTOR SUPPLY / REGENERATION RESISTOR

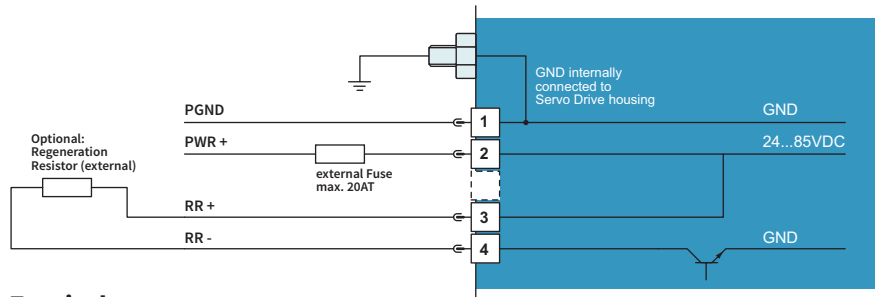
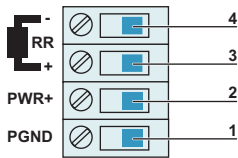

Screw Terminals:

External Regeneration Resistor (RR01-10/60, Art. Nr. 0150-3088)
 External Fuse: max. 20AT
 Supply nominal 72VDC (24...85VDC)
 (See chapter Power Supply Requirements for compatible power supplies.)
 Absolute max. Rating 72VDC +20%.

If motor supply voltage is exceeds 90VDC, the drive will go into error state.

- » Tightening torque: 0.5 - 0.6 Nm (4.4 – 5.3 lbin)
- » Screw thread: M2.5
- » Use 60/75°C copper conductors only
- » Conductor cross-section: use only 2.5 mm² / AWG 14
- » Stripping length: 13-15 mm
- » Max. length: 4 m

X2 MOTOR PHASES

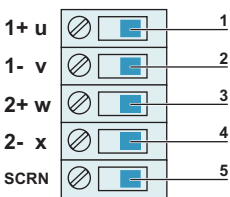

Nr	Designation	LinMot Linear Motor	Color	3-Phase-Motor
1	PH1+ /U	Motor Phase 1+	red	Motor Phase U
2	PH1- /V	Motor Phase 1-	pink	Motor Phase V
3	PH2+ /W	Motor Phase 2+	blue	Motor Phase W
4	PH2- /X	Motor Phase 2-	grey	Motor Phase X
5	SCRND	Shield		

Screw Terminals:

- » Tightening torque: 0.5 - 0.6 Nm (4.4 – 5.3 lbin)
- » Screw thread: M2.5
- » Use 60/75°C copper conductors only
- » Conductor cross-section: 0.5 – 2.5 mm² (depends on Motor current) / AWG 21 -14
- » Stripping length 13-15 mm

X3 MOTOR ENCODER

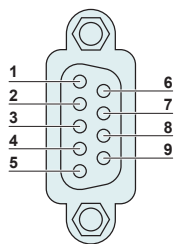

DSUB-9 (f)

Nr	LinMot Linear Motor	3-Phase-Motor
1		
2		
3	+5VDC	+5VDC (Hall Supply)
4	Sensor Sine	Hall 1
5	Temperature In	Hall 3
6		
7		
8	AGND	AGND (Hall Supply)
9	Sensor Cosine	Hall 2
Case	Shield	



Use +5VDC (X3.3) and AGND (X3.8) only for motor internal hall sensor supply (max. 100mA).

Caution :

Do NOT connect AGND (X3.8) to ground or earth!

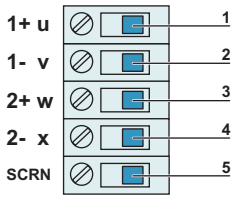

X2: Screw Terminals

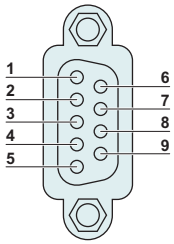

X3: DSUB-9 (f)

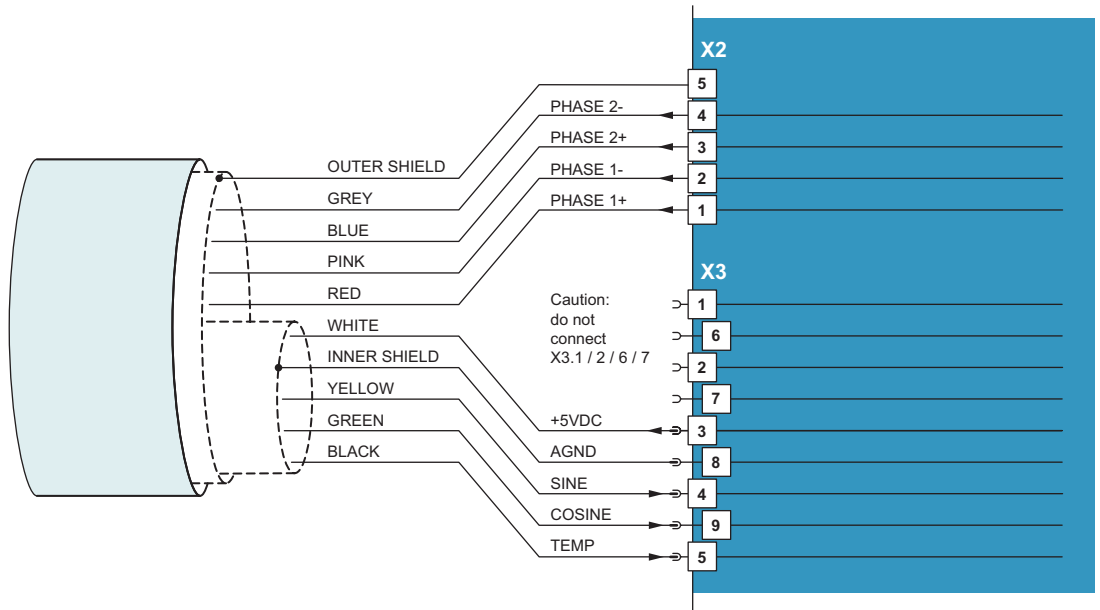

X4: 12PIN LOGIC CONTROL / SUPPLY

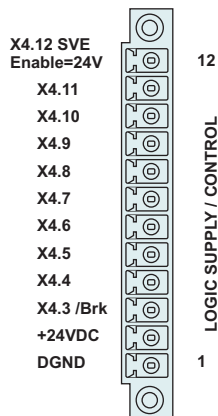

Phoenix MC1,5/12-STF-3,5 (delivered with drive)

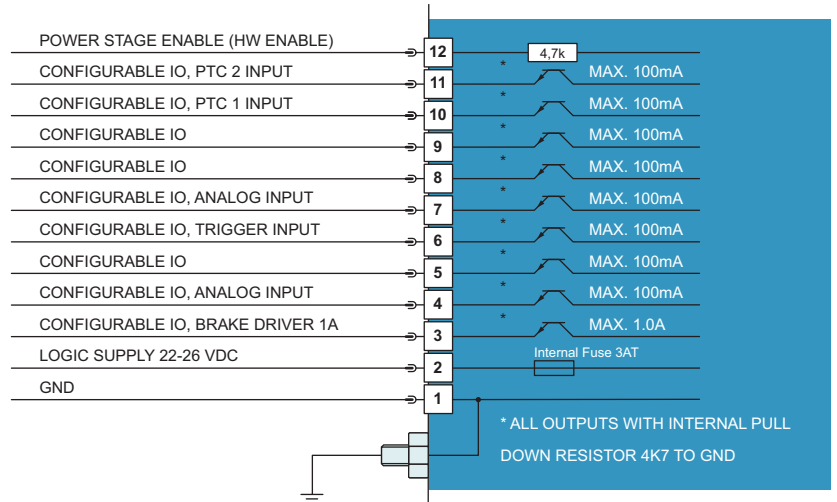

- Inputs (X4.3 .. X4.12):** 24V / 5mA (Low Level: -0.5 to 5VDC, High Level: 15 to 30VDC)
- Outputs (X4.4 .. X4.11):** 24V / max.100mA, Peak 370mA (will shut down if exceeded)
- Brake Output (X4.3):** 24V / max.1.0A

Input X4.12: SVE (PowerStage Enable) must be high for enabling the power stage). If it goes low for more than 0.5ms the PWM generation of the power stage is disabled by hardware.

Supply 24V / typ. 1.1A / max. 2.1A (if all outputs “on” with max. load and brake.)

- » Tightening torque: min 0.22Nm
- » Screw thread: M2
- » Use 60/75°C copper conductors only
- » Conductor cross-section: max. 1.5mm²
- » Internal Fuse (F2):3AT (slow blow, Schurter OMT125, 3404.0118.xx, UL File Number: E41599)



CAUTION: For continued protection against risk of fire, replace only with same type and rating of fuse.

X7 - X8 RS485/CAN

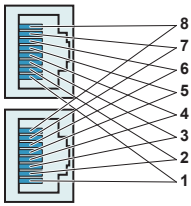

RJ-45

Nr		
1	RS485_Rx+	A
2	RS485_Rx-	B
3	RS485_Tx+	Y
4	GND	
5	GND	
6	RS485_Tx-	Z
7	CAN_H	
8	CAN_L	
Case	Shield	

- » Use twisted pair (1-2, 3-6, 4-5, 7-8) cable for wiring.
- » The built in CAN and RS485 terminations can be activated by S5.2 and S5.3.
- » X7 is internally connected to X8 (1:1 connection)

X9 PROFIBUS DP (ONLY AVAILABLE ON E1230-DP-UC)

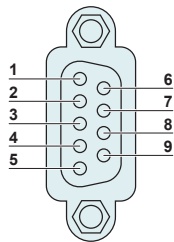

DSUB-9 (f)

Nr		
1	-	
2	-	
3	RxD/TxD-P	
4	CNTR-P	
5	GND	(isolated)
6	+5V	(isolated)
7	-	
8	RxD/TxD-N	
9	-	
Case	Shield	

Max. Baud rate: 12 Mbaud

X10-X11 MASTER ENCODER IN (X10) / MASTER ENCODER OUT (X11)

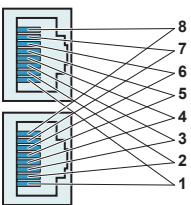

RJ-45

Nr	Incremental	Step/Direction	EIA/TIA 568A colors
1	A+	Step+	Green/White
2	A-	Step-	Green
3	B+	Direction+	Orange/White
4	Z+	Zero+	Blue
5	Z-	Zero-	Blue/White
6	B-	Direction-	Orange
7	CAN_H	CAN_H	Brown/White
8	CAN_L	CAN_L	Brown
Case	Shield	Shield	

Use twisted pair (1-2, 3-6, 4-5, 7-8) cable for wiring.

Master Encoder Inputs: Diff. RS422, max. counting frequency 25 Mcounts/s, quadrature evaluation, 40ns edge separation

Master Encoder Outputs: Amplified RS422 differential signals from Master Encoder IN (X10)

The CAN bus can be terminated with S5.4.

All devices, which are connected to X10/X11 must be referenced to the same ground.

X13 EXTERNAL POSITION SENSOR DIFFERENTIAL HALL SWITCHES / SSI

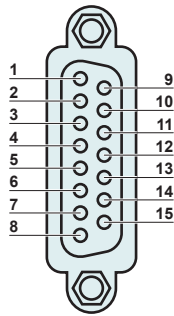

DSUB-15 (f)

Nr	ABZ with Hall Switches	Sin / Cos 1 Vpp	SSI (only position recovery)
1	+5V DC	+5V DC	+5VDC
2	9 A+	Sin+	
3	10 A-	Sin-	
4	11 B+	Cos+	
5	12 B-	Cos-	
6	13 Z+		Data+
7	14 Z-		Data-
8	12 Encoder Alarm	Encoder Alarm	
9	GND	GND	GND
10	13 U+		
11	14 U-		
12	15 V+		
13	16 V-		
14	17 W+		Clock+
15	18 W-		Clock-
Case	Shield	Shield	Shield

Position Encoder Inputs (RS422):

Encoder Simulation Outputs (RS422):

Differential Hall Switch Inputs (RS422):

Enc. Alarm In:

Sensor Supply:

Max. counting frequency: 25 Mcounts/s with quadrature decoding, 40ns edge separation
 Max Output Frequency: 2.5MHz, 5 M counts/s with quadrature decoding, 200ns edge separation
 Input Frequency: <1kHz
 5V / 1mA
 5VDC max 100mA

X15-X16 ETHERNET CONFIGURATION 10/100MBIT/S

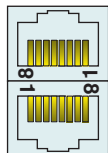

RJ-45

X15	Internal 2-Port 10BASE-T and 100BASE-TX Ethernet Switch with Auto MDIX. LEDs on the lower side of the device indicate "Link/Activity" per port, the upper ones are not used.
X16	

X17-X18 REALTIME ETHERNET 10/100 MBIT/S

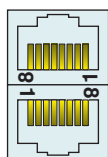

RJ-45

X17 RT ETH In	Specification depends on RT-Bus Type. Please refer to according documentation.
X18 RT ETH Out	

X19 RS232 CONFIGURATION

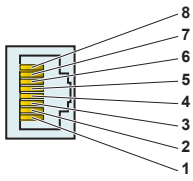

RJ-45

Nr	Description
1	Do not connect
2	Do not connect
3	RS232 RX
4	GND
5	GND
6	RS232 TX
7	Do not connect
8	Do not connect
case	Shield

Use isolated USB-RS232 converter (Art.-No. 0150-2473) for configuration over RS232.

X20 ANALOG IN (+-10V DIFFERENTIAL ANALOG INPUT)

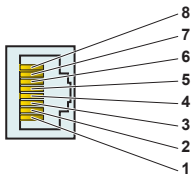

RJ-45

Nr	Description
1	Do not connect
2	Do not connect
3	Analog In-
4	GND
5	GND
6	Analog In+
7	Do not connect
8	Do not connect
case	Shield

S5 BUS TERMINATION / ANIN2 PULL DOWN



S5

Switch	E1200
S5	Switch 1: AnIn2 Pulldown (4k7 Pulldown on X4.4). Set to ON, if X4.4 is used as digital Output. Switch 2: Termination Resistor for RS485 on CMD (120R between pin 1 and 2 on X7/X8) on/off Switch 3: CAN Termination on CMD (120R between pin 7 and 8 on X7/X8) on/off Switch 4: CAN Termination on ME (120R between pin 7 and 8 on X10/X11) on/off Factory settings: all switches "off"

LEDS STATE DISPLAY



240VOK	Green	24V Logic Supply OK
EN	Yellow	Motor Enabled / Error Code Low Nibble
Warn	Yellow	Warning / Error Code High Nibble
Error	Red	Error

RT BUS LEDS



BUS OK	Green	OK
BUS Error	Red	Error

The use of these LEDs depends on the type of fieldbus which is used. Please see the corresponding manual for further information.

S1-2 ADDRESS SELECTORS / BUS TERMINATION

E12x0 V1



S1



S2

Switch	
S1	Bus ID High (0...F). Bit 5 is LSB, bit 8 MSB
S2	Bus ID Low(0...F). Bit 1 is LSB, bit 4 MSB

The use of these switches depends on the type of fieldbus which is used. Please see the corresponding manual for further information.

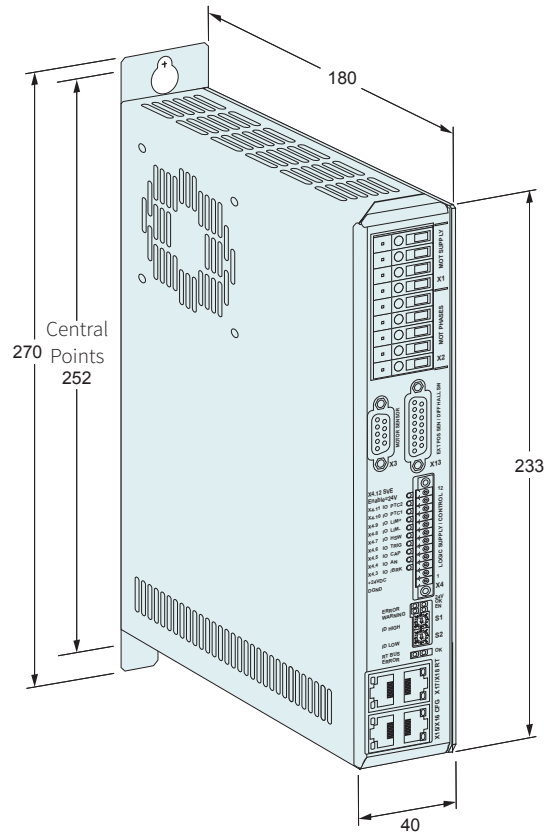

Dimensions in mm

11

Servo Drive Series		E1200
Width	mm (in)	40 (1.6)
Height	mm (in)	270 (10.6)
Height without fixings	mm (in)	233 (9.2)
Depth	mm (in)	180 (7.1)
Weight	kg (lb)	1.5 (3.3)
Case IP Code	IP	20
Mounting screws	mm (in)	2 x M5
Mounting distance	mm (in)	252 (9.92)
Storage temperature	°C	-25...40
Transport temperature	°C	-25...70
Operating temperature	°C	0...40 at rated date 40...50 with power derating
Relative humidity		95% (non-condensing)
Max. case temperature	°C	65
Max. power dissipation	W	30
Distance between Drives	mm (in)	20 (0.8) left/right 50 (2) top/bottom

Servo Drives		
Item	Description	Part Number
E1250-PL-UC	POWERLINK Servo Drive 72VDC/32A	0150-1760
E1250-PN-UC	PROFINET Servo Drive 72VDC/32A	0150-1762
E1250-PD-UC	ProfiDrive Servo Drive 72VDC/32A	0150-2620
E1250-EC-UC	EtherCAT Servo Drive 72VDC/32A	0150-1763
E1250-SE-UC	sercos over EtherCAT Servo Drive 72VDC/32A	0150-1898
E1250-DS-UC	EtherCAT CoE Servo Drive 72VDC/32A	0150-2410
E1250-SC-UC	sercos Servo Drive 72VDC/32A	0150-1764
E1250-IP-UC	ETHERNET IP Servo Drive 72VDC/32A	0150-1761
E1250-LU-UC	LinUDP Servo Drive 72VDC/32A	0150-2493
E1230-DP-UC	PROFIBUS-DP Servo Drive 72VDC/32A	0150-1766
E1200-GP-UC	GENERAL PURPOSE Servo Drive 72VDC/32A	0150-1771

Accessories		
Item	Description	Part Number
Connector for X4	Connector MC 1,5/12-STF-3,5, delivered with drive	0150-3300

Dotted lines for notes.

SERIES C1400



- ✓ Input voltage 230VAC
- ✓ 15A rms peak phase current
- ✓ Integrated Line Filter
- ✓ For LinMot P10 Linearmotors & AC servomotors
- ✓ Integrated Cooling Fan
- ✓ 100 programmable motion profiles
- ✓ 255 storable motion commands
- ✓ Interface for incremental or absolute sensors

Servo Drive Series C1400

Series C1400 Servo Drives are modular axis drives, with 32-bit position resolution and an integrated power stage 1x240VAC, for linear motors and rotary motors.

The drives are suitable for simplest, standard, and high-end positioning tasks.



CONNECTION TO MACHINE DRIVE

The Series C1400 Servo Drives can be actuated by machine controls from many manufacturers or brands, via digital inputs and outputs, or industrial ETHERNET.

PROCESS AND SAFETY INTERFACES

Fast process interfaces for direct processing of sensor signals are available as freely programmable analog and digital inputs, a fast trigger input, and a capture input.

The safety IO's on Servo Drives with the -1S option with industrial ETHERNET allows safe torque off (STO) of the drives via control signals, without interrupting the power supply.

LOGIC AND POWER SUPPLY

In an E-stop and safe stop of the drive, only the motor power supply is cut off from the drive. The logic supply and the drive continue to run.

This has the advantage that the drive and linear motor do not need to be reinitialized when the machine is restarted, since all process data, including the position of the linear motor are still up to date (as long as the logic supply is not turned off).

System Integration

Flexible hardware enables control of any 1/2/3- phase motors. Thus, low-power rotary servomotors, such as brushless DC motors, can be integrated in the same controls concept.

Additionally, the drives can be equipped with optional peripherals, such as reference and end stop switches, high-precision external position sensors, or a mechanical holding brake.

Series C1400 Servo Drives have analog and digital inputs and outputs and ETHERNET connections. The user is therefore not dependent on the selection of the overlaid drive. An appropriate interface is available, with associated protocols, for many PLC or IPC solutions.

With flexibility and a compact form factor, LinMot Series C1400 Servo Drives provide a complete solution for a flexible drive concept in single and multiple axes applications, with linear motors and other actuators.

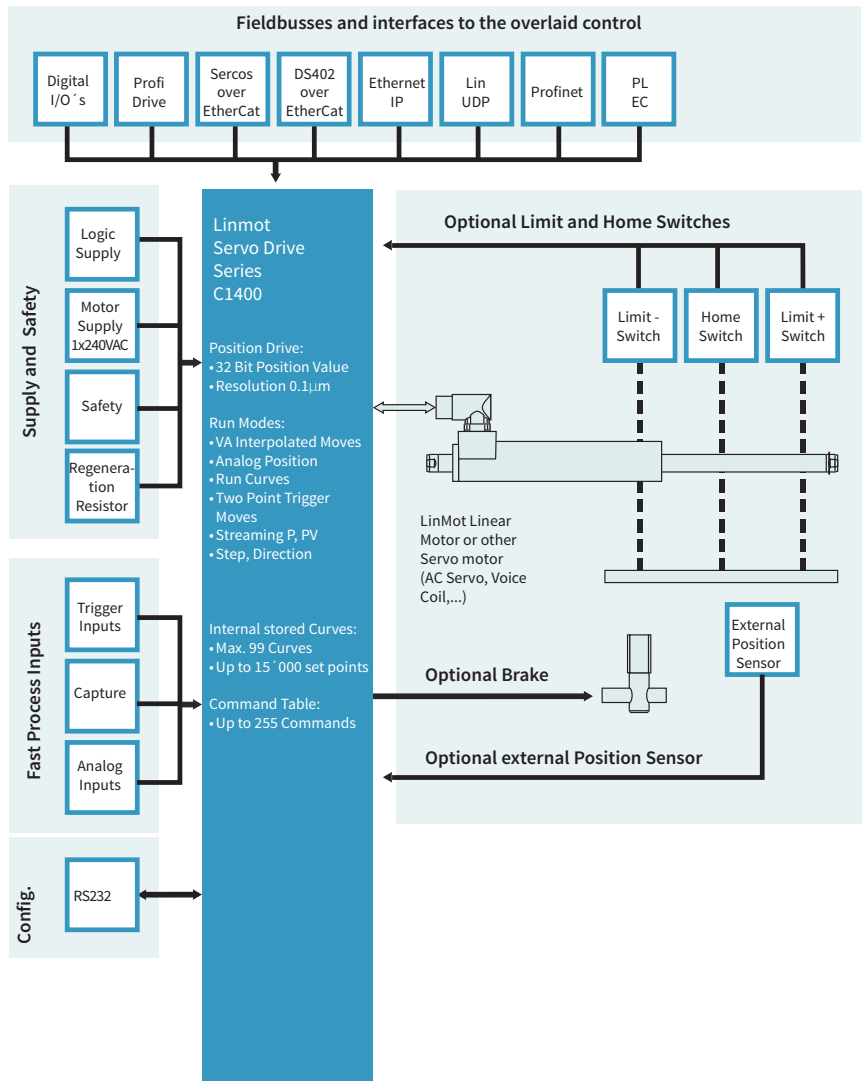

MOTOR INTERFACES

C1400 Servo Drives provide all necessary interfaces to operate linear or rotary motors with optional external peripherals, such as end position and reference switches, a mechanical brake, or a high-resolution external position sensor.

CONFIGURATION

LinMot Talk user-friendly PC software is available for configuration. In addition to online documentation, LinMot Talk provides extensive debugging tools, such as an oscilloscope and an error inspector, for simple and rapid start-up of the Axis.

Fieldbus and ETHERNET drives can also be configured directly by the overlaid control.

INTERPOLATED MOVES

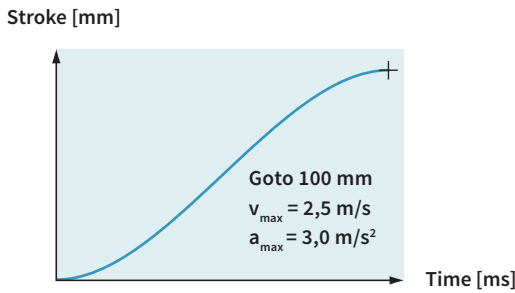

For direct position targets, using absolute or relative positioning, the desired position is reached using acceleration and velocity-limited motion profiles or jerk optimized profiles (jerk limited and Bestehorn). Positioning commands can be invoked via the serial interfaces, CANopen, DeviceNet, Profibus, Ethernet or a trigger input.

Stroke range:	±100 m
Position Resolution:	0.1 µm (32Bit)
Velocity Resolution:	1.0 µm/s (32Bit)
Acceleration Resol.:	10.0 µm/s ² (32Bit)

TIME CURVES

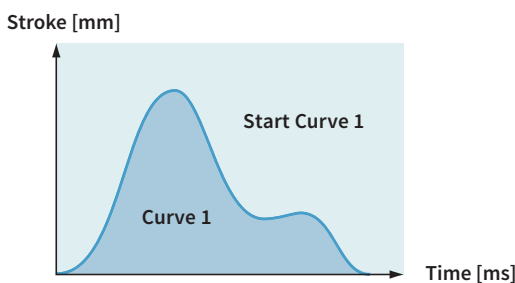

Up to 100 different time curves can be stored Series C1200 drives, with up to 16,000 individual waypoints. The motor can thus travel along time curves of any complexity, such as those generated by CAD programs and stored in the drive (Excel CSV format). The time curves can be invoked via the serial interface, fieldbuses, Ethernet, or the trigger input.

Stroke range:	±100m
Position Resolution:	0.1 µm (32Bit)
Motion profiles:	Max. 100 Time Curves
Curve points:	Max. 16'000 points

PROFILED MOVES

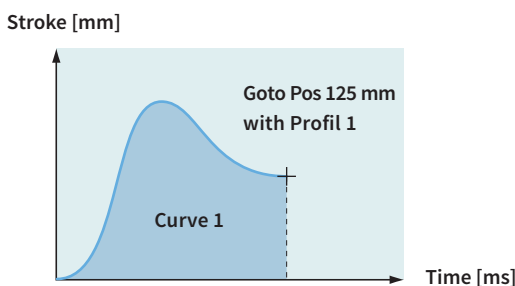

For travel to an absolute position, or shifting by a relative position, any desired motion rules can be stored besides the VA interpolator. They are stored in the drive as motion profiles (Excel CSV format). The positions can be approached, for example, with a sinusoidal motion to optimize power loss, or special reverse optimized motion profiles.

Stroke range:	±100m
Position Resolution:	0.1 µm (32Bit)
Motion profiles:	Max. 100 Time Curves
Curve points:	Max. 16'000 points

SETPOINT STREAMING

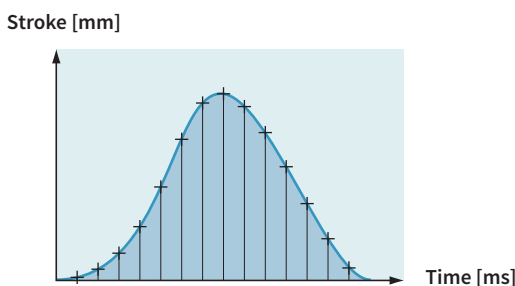

Overlaid NC drives with fieldbus or Ethernet interfaces communicate with the servo drives via "Position Streaming". The position and velocity calculated in the overlaid control is transmitted to the Servo Drive cyclically. The P, PV, or PVT mode is available for this transmission.

Position Resolution:	32 Bit
Velocity Resolution:	32 Bit
Interpolator:	8 kHz
Cycle times:	0.25 - 5 ms

EASY STEPS

Input 1	Pos 125 mm
Input 2	Pos 250 mm
Input 3	Curve 1
Input 4	Pos -30 mm

With the Easy Steps function, up to 4 positions or independent travel commands can be stored on the drive, and addressed via 4 digital inputs or fieldbus interfaces/Ethernet.

Digital inputs: max. 4
Interface: X4
Scanning rate: 250 µsec

COMMAND TABLE

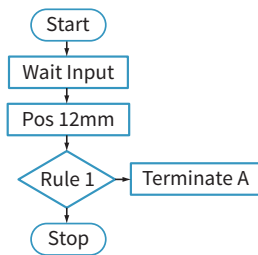

Entire motion sequences with up to 255 individual motion commands can be stored in the Command Table. This is primarily advantageous if complete motion sequences need to be executed very quickly, without dead time from the overlaid drive. In the Command Table, the programmer has access to all motion commands, internal parameters, and digital inputs and outputs.

Commands: max. 254
Cycle time: 125 µsec

ANALOG POSITION

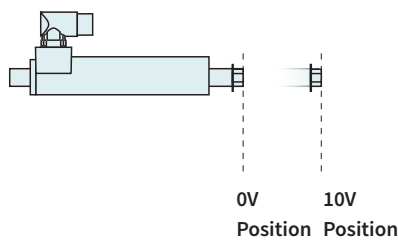

For an analog position target, the linear motor travels to a position proportional to the input voltage. The position is either scanned continuously, or only after a rising edge of the trigger signal. In order to prevent uncontrolled jumps in position, the motor travels to the positions with a programmable maximum acceleration and velocity (VA interpolator).

Inputs: Analog Input X4
Voltage range: 0-10VDC or ±10V
Resolution: 12 Bit
Scanning rate: >=125 µsec (adjustable)

EASY STEPS PARAMETER SCALE

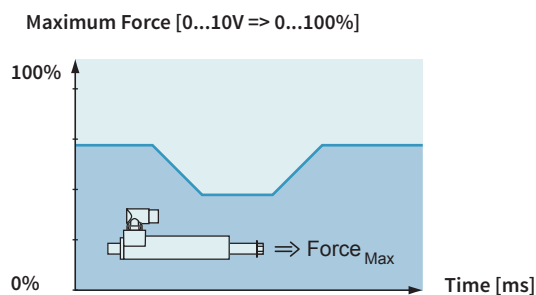

Easy Steps provide the ability to parameterize internal parameters using two analog inputs. If, for example, the maximum motor current is read at an analog input, then the maximum motor force can be provided as analog for freely programmable joining processes.

Inputs: 2 x Analog
Voltage range: 0-10VDC
Resolution: 12 Bit
Scanning rate: 250 µsec

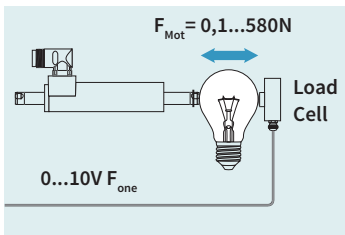
CLOSED LOOP FORCE CONTROL

Using the force control technology function, precise joining processes can be implemented reliably and reproducibly with high-precision force control. For force control, the current motor force is measured with a load cell and controlled in the drive. Joining process or quality checks with high requirements for applied force can be implemented.

Analog input:	0-10V or $\pm 10V$
Resolution:	12 Bit
Min. Force Resolution:	0.1N

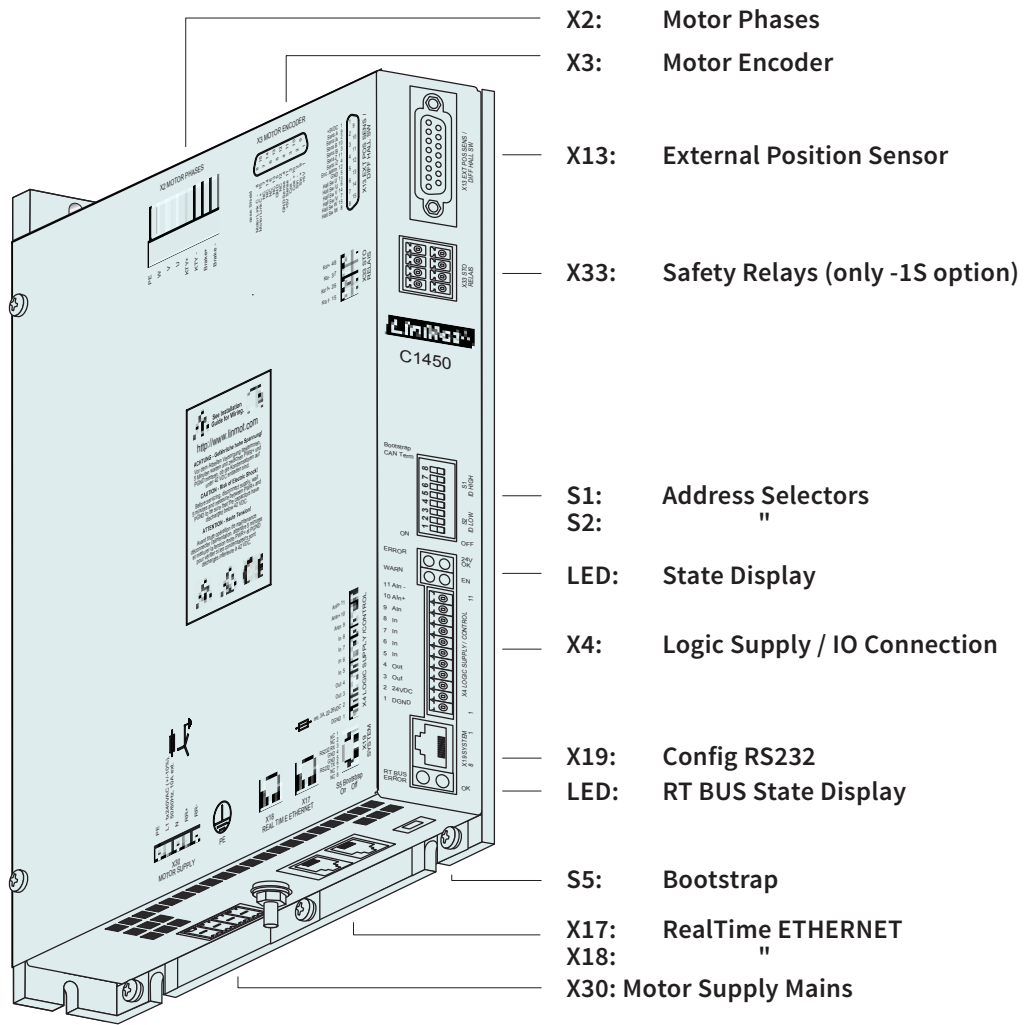

Interfaces	C1450-PN-VS-1S	C1450-PD-VS-1S	C1450-SC-VS-1S	C1450-IP-VS-1S	C1450-LU-VS-1S	C1450-EC-VS-1S	C1450-DS-VS-1S	C1450-SE-VS-1S	C1450-PL-QN-1S
PROFINET	•								
PROFINET Profidrive		•							
SERCOS III			•						
ETHERNET IP				•					
LinUDP					•				
ETHERCAT						•			
ETHERCAT CiA402							•		
ETHERCAT SoE								•	
POWERLINK									•



- C1450-PN-VS -1S**
- C1450-PD-VS -1S**
- C1450-SC-VS -1S**
- C1450-IP-VS -1S**
- C1450-LU-VS -1S**
- C1450-EC-VS -1S**
- C1450-DS-VS -1S**
- C1450-SE-VS -1S**
- C1450-PL-QN -1S**

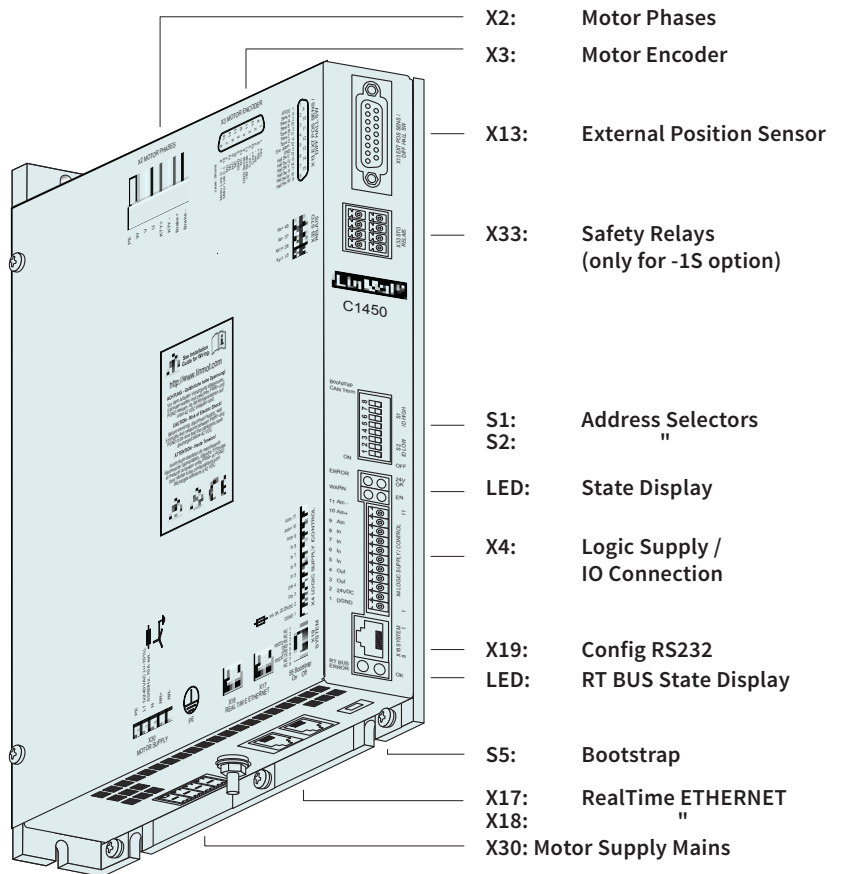

- » Absolute & Relative Positioning
- » Time based motion profiles
- » Internally stored Motion Sequences
- » Position Streaming
- » Analog Position Target
- » Analog Parameter Scaling
- » Winding Function Block
- » Force Control Technology Function
- » Customer-Specific Functions

INDUSTRIAL ETHERNET

Series C1400 drives allow integration of LinMot linear motors in controls concepts with industrial Ethernet interfaces. The user can integrate Series C1400 drives regardless of the provider of the overlaid control.

LinMot drives are available with common industrial Ethernet protocols. Since all Ethernet drives have the same motion command interface, and the control and status word are identical, software blocks that have been implemented once can be transferred to other drives without a problem.

Series C1400 servo drives support the following industrial Ethernet protocols:

- » Profinet
- » EtherCAT
- » Ethernet IP
- » PowerLink
- » Sercos III
- » Sercos over EtherCAT

The appropriate drive is available for each protocol.

TECHNICAL DATA

Type: Realtime ETHERNET
 Switch/Hub: Integrated 2-Port Hub/Switch
 Transfer rate: 10/100MBit/sec

Minimal cycle times:
 Bus cycle: 250 µs
 IO update: 250 µs
 Trigger Input: 125 µs
 Position control loop: 125 µs
 Current control loop: 125 µs

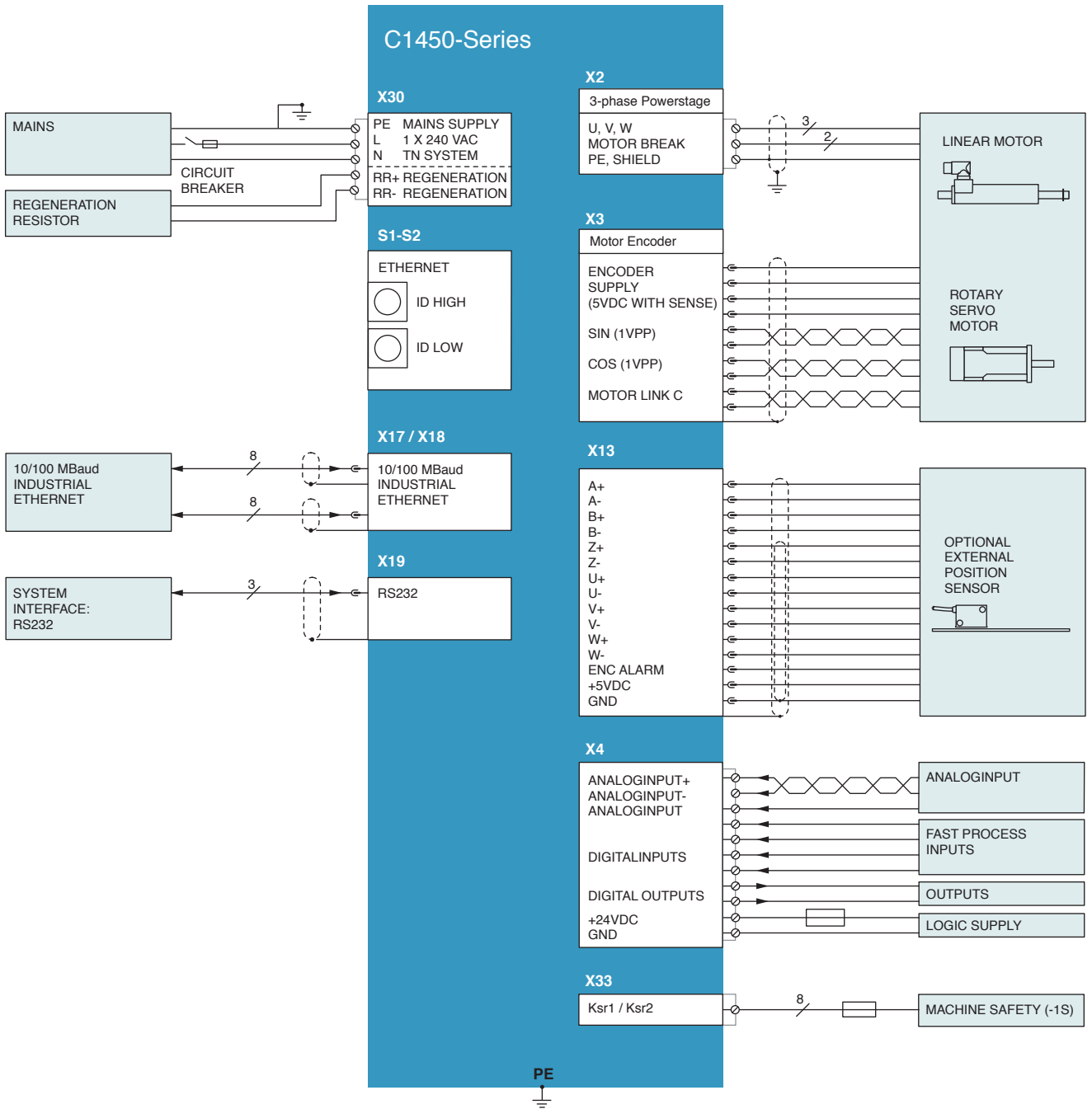

X30 MOTOR SUPPLY MAINS / REGENERATION RESISTOR

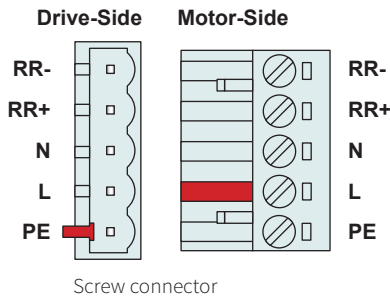

	Designation
RR-	Regeneration Resistor
RR+	Regeneration Resistor
N	Neutral (TN system with grounded Neutral)
L	Line 1 (1x240VAC (+-10%) 50/60Hz external fuse: max.10A)
PE	Protective Earth

Line filter is integrated into the drive.

Screw Terminals:

- » Tightening torque: 0.5 - 0.6 Nm
- » Screws: M3
- » Use 60/75°C copper conductors only
- » Conductor cross-section: 2.5 mm² (AWG 12)
- » Stripping length 7 mm

LinMot Article Number:
0150-3607 (DC01-C1400/X30)



Operating of the drive is only allowed with the above article! No other type of connector shall be used!

X2 MOTOR PHASES

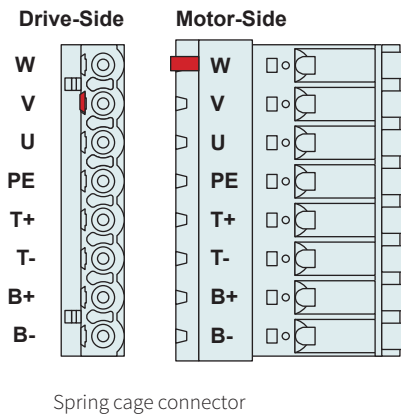

Nr	Designation
W	Motor Phase W
v	Motor Phase V
U	Motor Phase U
PE	Protective Earth
T+	Temperature Sensor KTY+
T-	Temperature Sensor KTY-
B+	Motor Brake+
B-	Motor Brake-



The Shield of the motor cable has to be mounted with a surface as large as possible (low ohm, low impedance). Use an EMC shield clamp for fixing.

Attention: An isolated thermistor is necessary! Especially LinMot D01 and D02 Motors can not be connected!

Screw Terminals:

- » Spring-cage connector
- » Use 60/75°C copper conductors only
- » Conductor cross-section: 0.2–2.5 mm² (depends on Motor current)/AWG 24-12
- » Stripping length 10 mm

LinMot Article Number:
0150-3605



Operating of the drive is only allowed with the above article! No other type of connector shall be used!

X3 MOTOR ENCODER (MOTOR LINK C) / NOT AVAILABLE ON -CO DRIVES!

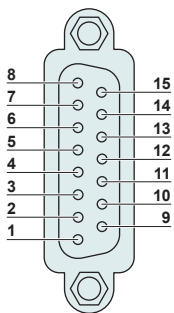

DSUB-15 (m)

Nr	Description
8	Motor Link C-
15	Motor Link C+
7	do not connect
14	do not connect
6	do not connect
13	do not connect
5	GND
12	do not connect
4	GND Sense
11	+5V Sense
3	Cos-
10	Cos+
2	Sin-
9	Sin+
1	+5V-
Case	Shield

Motor Link C is a high speed serial communication protocol to the motor encoder

X4 LOGIC SUPPLY / IO CONNECTION

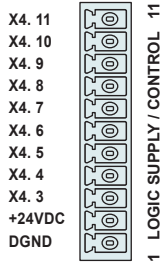

Spring cage connector

LinMot Article Number:
0150-3447 (DC01-Signal/X4)



Operating of the drive is only allowed with the above article! No other type of connector shall be used!

Nr	Description	
11	AnIn-	X4.11 Configurable Analog Input deifferentiell (with X4.10)
10	AnIn+	X4.10 Configurable Analog Input deifferentiell (with X4.11)
9	AnIn	X4.9 Configurable Analog Input single ended
8	In	X4.8 Configurable Input
7	In	X4.7 Configurable Input
6	In	X4.6 Configurable Input
5	In	X4.5 Configurable Input
4	Out	X4.4 Configurable Output
3	Out	X4.3 Configurable Output
2	+24VDC	Supply Logic Supply 22-26 VDC
1	GND	Supply Ground

Inputs (X4.5 .. X4.8): 24V / 5mA (Low Level: -0.5 to 5VDC, High Level: 15 to 30VDC)
Outputs (X4.3 .. X4.4): 24V / max.100mA, Peak 370mA (will shut down if exceeded)

Analog Inputs: 12 bit A/D converted
X4.9: Single ended analog input to GND, 0..10V, Input Resistance 51kΩhm to GND
X4.10/X4.11: Differential analog input, +/-10V, Common mode range +/-5VDC to GND
 Input resistance 11.4kΩhm for each signal to GND.

- » Use 60/75°C copper conductors only
- » Conductor cross-section max. 1.5 mm²
- » Stripping length: 10 mm
- » The 24VDC supply for the control circuit (X4.2) must be protected with an external fuse (3A slow blow)

X13 EXTERNAL POSITION SENSOR DIFFERENTIAL HALL SWITCHES

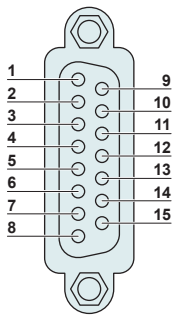

DSUB-15 (f)

Nr	SSI / BiSS / EnDat	
1	+5V DC	
2	9	A+
3	10	A-
4	11	B+
5	12	B-
6	13	Z+
7	14	Z-
8	15	Encoder Alarm
9	GND	
10	13	U+
11	14	U-
12	15	V+
13	1	V-
14	2	W+
15	3	W-
Case	Shield	

Position Encoder Inputs (RS422): Max Input Frequency: 25 M counts/s with quadrature decoding, 40ns edge separation
Encoder Simulation Outputs (RS422): Max Output Frequency: 4 M counts/s with quadrature decoding, 250ns edge separation
Differential Hall Switch Inputs (RS422): Input Frequency: <1kHz
Enc. Alarm In: 5V / 1mA
Sensor Supply: 5VDC max. 100mA / 9VDC 100mA (SW selectable)

X17 - X18 REALTIME ETHERNET 10/100 MBIT/S (NOT AVAILABLE ON -CO DRIVES)

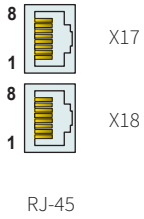

Nr		
X17	RT ETH In	Specification depends on RT-Bus. Please refer to interface documentation.
X18	RT ETH Out -	

X19 SYSTEM

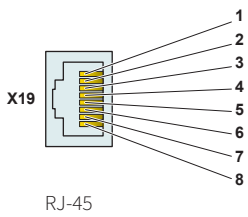

Nr	Description
1	Do not connect
2	Do not connect
3	RS232 Rx
4	GND
5	GND
6	RS232 Tx
7	Do not connect
8	Do not connect

Use isolated USB-RS232 converter (Art.-No. 0150-2473) for configuration over RS232.

LEDS

STATE DISPLAY



24VOK	Green	24V Logic Supply OK
EN	Yellow	Motor Enabled / Error Code Low Nibble
Warn	Yellow	Warning / Error Code High Nibble
Error	Red	Error

RT BUS LEDS



BUS OK	Green	OK
BUS Error	Red	Error

The use of these LEDs depends on the type of fieldbus which is used. Please see the corresponding manual for further information.

S1 -S2

ADDRESS SELECTORS



Switch	
S1 (5..8)	Bus ID High (0 ... F). Bit 5 is the LSB, bit 8 the MSB.
S2 (1..4)	Bus ID Low (0 ... F). Bit 1 is the LSB, bit 4 the MSB.

The use of these switches depends on the type of fieldbus which is used. Please see the corresponding manual for further information.

S5

BOOTSTRAP

The switch is used for initial programming. Make sure the switch is in position "off". Otherwise the drive will not start up.

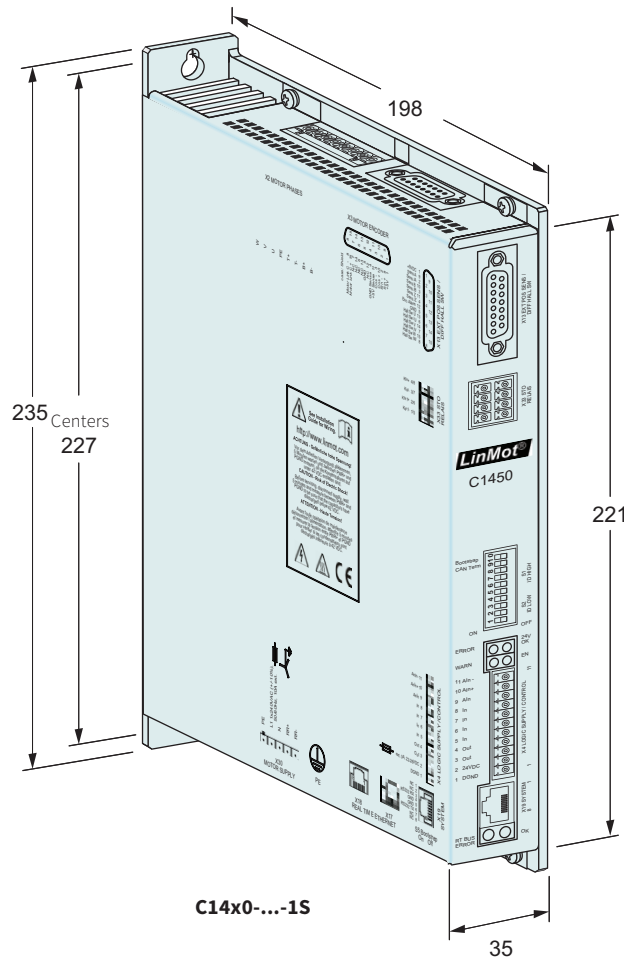

Dimensions in mm

Servo Drive Series		C14x0-...-1S
Width	mm (in)	43.5 (1.71)
Height	mm (in)	235 (9.25)
Depth	mm (in)	193 (7.60)
Weight	kg (lb)	
Mounting		Backside 2 x M4 Bottom Side 4 x M4
Case IP Code	IP	20
Storage temperature	°C	-25...40
Transport temperature	°C	-25...70
Operating temperature	°C	0...40
Relative humidity		95% (non-condensing)
Pollution	IEC/EN 60664-1	Pollution degree 2
Shock resistance (16 ms)	-1S option	2 g
Vibration resistance (10-200 Hz)	-1S option	1 g
Max. Case Temperature	°C	90
Max. Power Dissipation	W	100
Mounting place		In the control cabinet
Mounting position		vertical
Distance between drives	mm (in)	≥ 200 (8) top /bottom Drives with fans can be mounted vertically side by side

Servo Drives		
Item	Description	Part Number
C1450-SE-VS-1S-000	EtherCAT SoE Drive (1x240V/20A), STO	0150-2660
C1450-SC-VS-1S-000	Sercos III Drive (1x240V/20A), STO	0150-2659
C1450-PN-VS-1S-000	ProfiNet Drive (1x240V/20A), STO	0150-2658
C1450-PL-VS-1S-000	POWERLINK Drive (1x240V/20A), STO	0150-2656
C1450-PD-VS-1S-000	PROFIdrive Drive (1x240V/20A), STO	0150-2664
C1450-IP-VS-1S-000	Ethernet/IP Drive (1x240V/20A), STO	0150-2666
C1450-EC-VS-1S-000	EtherCAT Drive (1x240V/20A), STO	0150-2657
C1450-DS-VS-1S-000	EtherCAT CoE Drive (1x240V/20A), STO	0150-2665
C1400-LU-VS-1S-000	LinUDP Drive (1x240V/20A), STO	0150-2667

SERIES E1400



- ✓ 3x400...480VAC
- ✓ Controls LinMot motors / AC servomotors
- ✓ Time Curves
- ✓ Real Time (Streaming)
- ✓ Synchronous control (Drive profiles)
- ✓ Master Encoder Synchronization (In/Out)
- ✓ PLC or Stand-Alone Solutions
- ✓ Industrial Ethernet Configuration / Remote Access Ethernet
- ✓ Safe Torque Off
- ✓ Safe Limited Speed Ready
- ✓ Interface for optional incremental and absolute sensor
- ✓ Position Encoder Simulation (RS 422)
- ✓ Master / Slave Solutions
- ✓ ± 10 VDC Force / Speed Control
- ✓ Supports Plug and Play

Servo Drive Series E1400

Series E1400 Servo Drives are modular axis drives, with 32-bit position resolution and an integrated power stage 3x400VAC, for linear motors and rotary motors.

The drives are suitable for simplest, standard and high-end positioning tasks across the entire force range of the LinMot product range.



CONNECTION TO MACHINE DRIVE

The Series E1400 Servo Drives can be actuated by machine controls from many manufacturers or brands, via digital inputs and outputs, RS232 or RS485 serial interface, CanBus CANopen and DeviceNet interfaces, Profibus DP, or industrial ETHERNET.

PROCESS AND SAFETY INTERFACES

Fast process interfaces for direct processing of sensor signals are available as freely programmable analog and digital inputs, a fast trigger input, and a capture input.

The safety interface on Servo Drive with fieldbus interfaces or industrial ETHERNET allows safe stop of the drives via control signals, per EN 954-1, without interrupting the power supply.

LOGIC AND POWER SUPPLY

The Servo Drives have two separate power supply inputs for the logic and power elements.

In an E-stop and safe stop of the drive, only the power element supply is cut off from the drive. The logic supply and the drive continue to run.

This has the advantage that the drive and linear motor do not need to be reinitialized when the machine is restarted, since all process data, including the current position of the linear motor, are still up to date.

System Integration

Flexible hardware enables control of any 1/2/3- phase motors. Thus, low-power rotary servo-motors, such as brushless DC motors, can be integrated in the same control concept.

Additionally, the drives can be equipped with optional peripherals, such as reference and end stop switches, high-precision external position sensors, or a mechanical holding brake.

Series E1400 Servo Drives have analog and digital inputs and outputs, serial interfaces, field-busses, and ETHERNET connections. The user is therefore not dependent on the selection of the overlaid drive. An appropriate interface is available, with associated protocols, for any PLC or IPC solution.

With flexibility and a compact form factor, LinMot Series E1400 Servo Drives provide a complete solution for a flexible drive concept in single and multiple axes applications, with linear motors and other actuators.

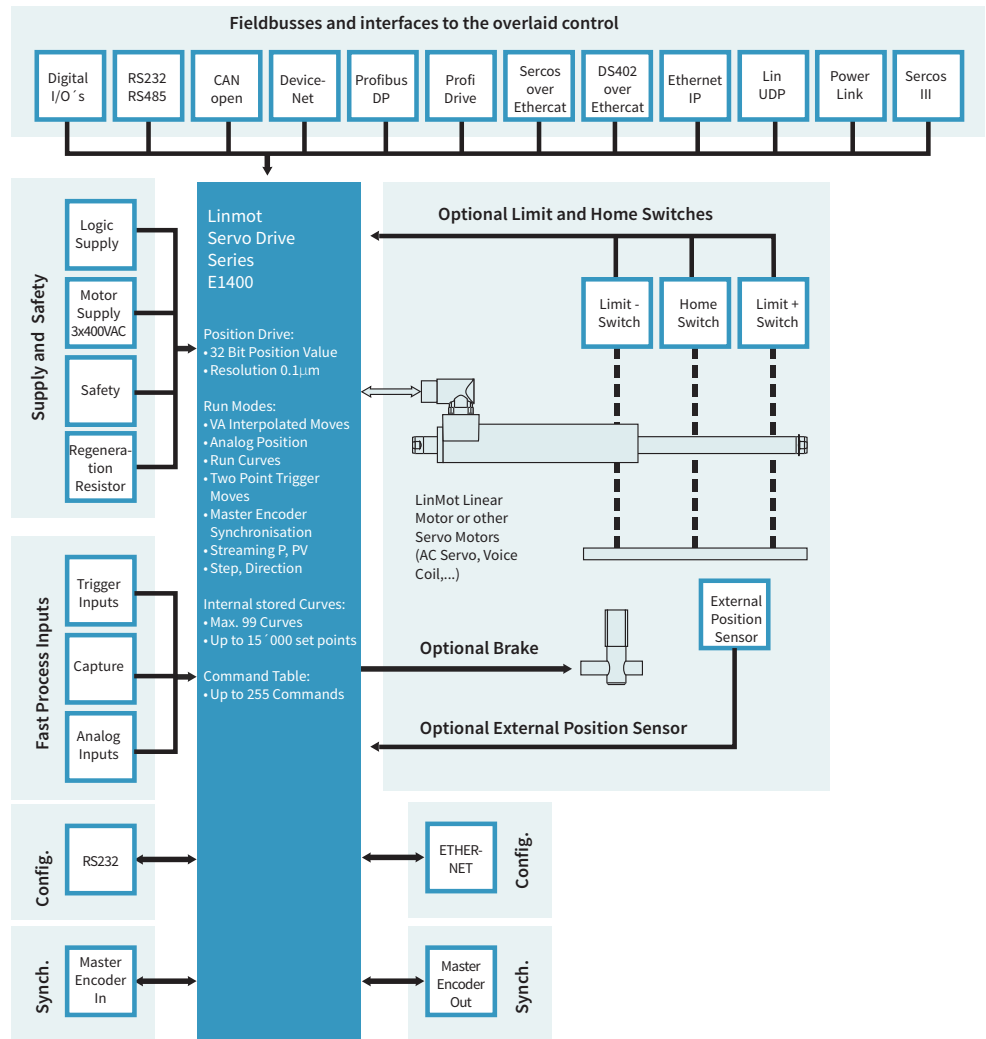

MASTER ENCODER

For synchronization to a mechanical master shaft, or a rotating main drive, the Axis (linear motors and rotary motors) can be coupled to an electronic main shaft via the Master Encoder Interface.

The encoder signal from the main shaft can be passed through by the Master Encoder Interface, so that any number of linear motors can be synchronized to the main shaft.

MOTOR INTERFACES

E1400 Servo Drives provide all necessary interfaces to operate linear or rotary motors with optional external peripherals, such as end position and reference switches, a mechanical brake, or a high-resolution external position sensor.

CONFIGURATION

Parameterization and configuration of the Servo Drive is done via the Ethernet interface on the front side for simultaneous configuration of several drives.

LinMot Talk user-friendly PC software is available for configuration. In addition to online documentation, LinMot Talk provides extensive debugging tools, such as an oscilloscope and an error inspector, for simple and rapid start-up of the Axis.

Fieldbus and ETHERNET drives can also be configured directly by the overlaid control.

INTERPOLATED MOVES

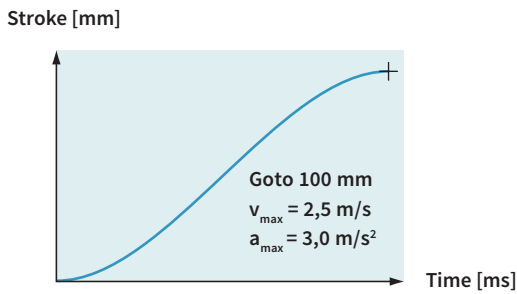

For direct position targets, using absolute or relative positioning, the desired position is reached using acceleration and velocity-limited motion profiles or jerk optimized profiles (jerk limited and Bestehorn). Positioning commands can be invoked via the serial interfaces, CANopen, DeviceNet, Profibus, Ethernet or a trigger input.

Stroke range:	±100 m
Position Resolution:	0.1 µm (32Bit)
Velocity Resolution:	1.0 µm/s (32Bit)
Acceleration Resol.:	10.0 µm/s ² (32Bit)

TIME CURVES

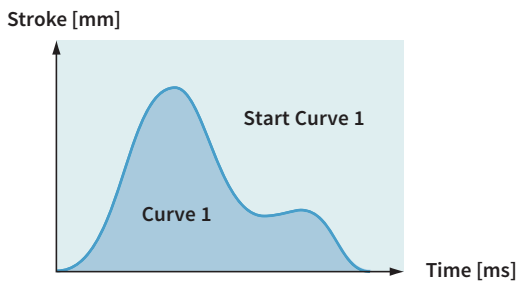

Up to 100 different time curves can be stored on Series E1400 drives, with up to 16`000 individual waypoints. The motor can thus travel along time curves of any complexity, such as those generated by CAD programs and stored in the drive (Excel CSV format). The time curves can be invoked via the serial interface, fieldbusses, ETHERNET, or the trigger input.

Stroke range:	±100m
Position Resolution:	0.1 µm (32Bit)
Motion profiles:	Max. 100 Time Curves
Curve points:	Max. 16'000 points

11

PROFILED MOVES

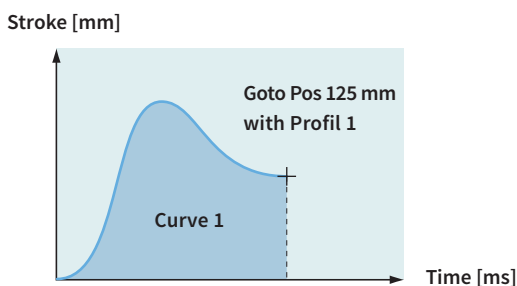

For travel to an absolute position, or shifting by a relative position, any desired motion rules can be stored besides the VA interpolator. They are stored in the drive as motion profiles (Excel CSV format). The positions can be approached, for example, with a sinusoidal motion to optimize power loss, or special reverse optimized motion profiles.

Stroke range:	±100m
Position Resolution:	0.1 µm (32Bit)
Motion profiles:	Max. 100 Time Curves
Curve points:	Max. 16'000 points

SETPOINT STREAMING

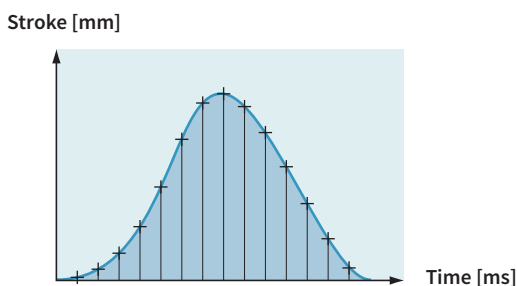

Overlaid NC drives with fieldbus or ETHERNET interfaces communicate with the Servo Drives via "Position Streaming". The position and velocity calculated in the overlaid control is transmitted to the Servo Drive cyclically. The P, PV, or PVT mode is available for this transmission.

Position Resolution:	32 Bit
Velocity Resolution:	32 Bit
Interpolator:	8 kHz
Cycle times:	0.25 - 5 ms

EASY STEPS

Input 1	Pos 125 mm
Input 2	Pos 250 mm
Input 3	Curve 1
Input 4	Pos -30 mm
Input 5	Pos +12,5 mm
Input 6	Curve 2
Input 7	Pos 2 mm
Input 8	Pos -12,5 mm

With the Easy Steps function, up to 8 positions or independent travel commands can be stored on the drive, and addressed via 8 digital inputs or fieldbus interfaces/ETHERNET.

Digital inputs: max. 8
Interface: X4
Scanning rate: 200 µsec

COMMAND TABLE

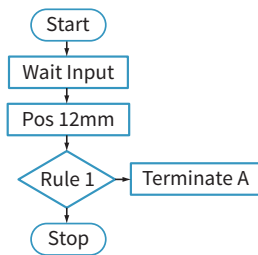

Entire motion sequences with up to 255 individual motion commands can be stored in the Command Table. This is primarily advantageous if complete motion sequences need to be executed very quickly, without dead time from the overlaid drive. In the Command Table, the programmer has access to all motion commands, internal parameters, and digital inputs and outputs.

Commands: max. 255
Cycle time: 100 µsec

MASTER ENCODER SYNCHRONIZATION (MT)

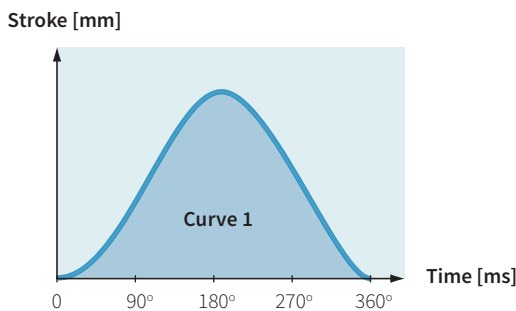

For synchronization to an external main or master shaft, the linear motor travels along the motion profiles stored in the drive, at the machine speed (machine angle 0...360°). Using this function, mechanical cam discs can be replaced with highly dynamic linear motors. The motion profiles can be freely defined, and the correct motion profile can be invoked during product changeover with no changeover time.

Motion profiles: Max. 100 curve profiles
Curve points: Max. 16'000 points
Encoder counter: 32 Bit
Encoder input: A/B/Z (RS422)
Max. counting frequency: Max. 4.5 MHz

BELT SYNCHRONIZATION

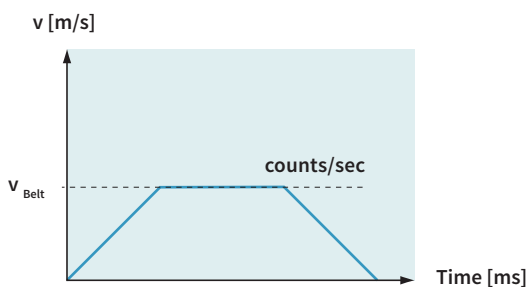

Synchronization to a belt speed can be done using the Master Encoder Interface or Step/Direction/ Zero interface. Applications such as the "flying saw", synchronous loading or unloading, synchronous filling or labeling of bottles or containers on a conveyor belt, and many other applications can be implemented in this way.

Encoder Counter: 32 Bit
Encoder Input: A/B/Z (RS422), max. 5 MHz
 STEP/DIR/ZERO
Max. counting frequency: Max. 4.5 MHz

ANALOG POSITION

For an analog position target, the linear motor travels to a position proportional to the input voltage. The position is either scanned continuously, or only after a rising edge of the trigger signal. In order to prevent uncontrolled jumps in position, the motor travels to the positions with a programmable maximum acceleration and velocity (VA interpolator).

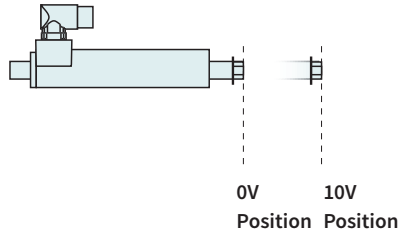

Inputs:	Analog Input X4 or X20
Voltage range:	0-10VDC or ±10V
Resolution:	12 Bit
Scanning rate:	>=100 µsec (adjustable)

EASY STEPS PARAMETER SCALE

Easy Steps provide the ability to parameterize internal parameters using two analog inputs. If, for example, the maximum motor current is read at an analog input, then the maximum motor force can be provided as analog for freely programmable joining processes.

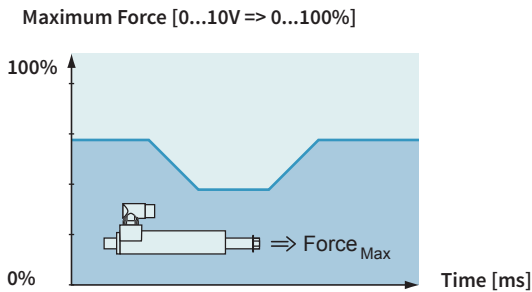

Inputs:	2 x Analog (X4.4, X4.7)
Voltage range:	0-10VDC
Resolution:	12 Bit
Scanning rate:	200 µsec

CLOSED LOOP FORCE CONTROL

Using the force control technology function, precise joining processes can be implemented reliably and reproducibly with high-precision force control. For force control, the current motor force is measured with a load cell and controlled in the drive. Joining process or quality checks with high requirements for applied force can be implemented.

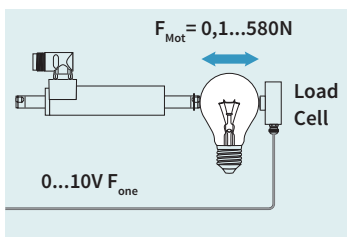

Analog Input:	0-10V or ±10V
Resolution:	12 Bit
Min. force resolution:	0.1N

WINDING APPLICATION

For winding textile yarns, glass fiber optics, or wires, a complete functional block is available that controls the entire sequence of a complete winding process.

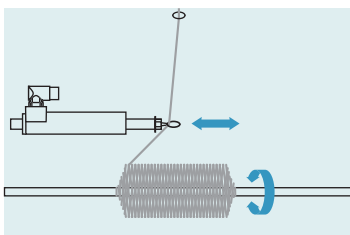

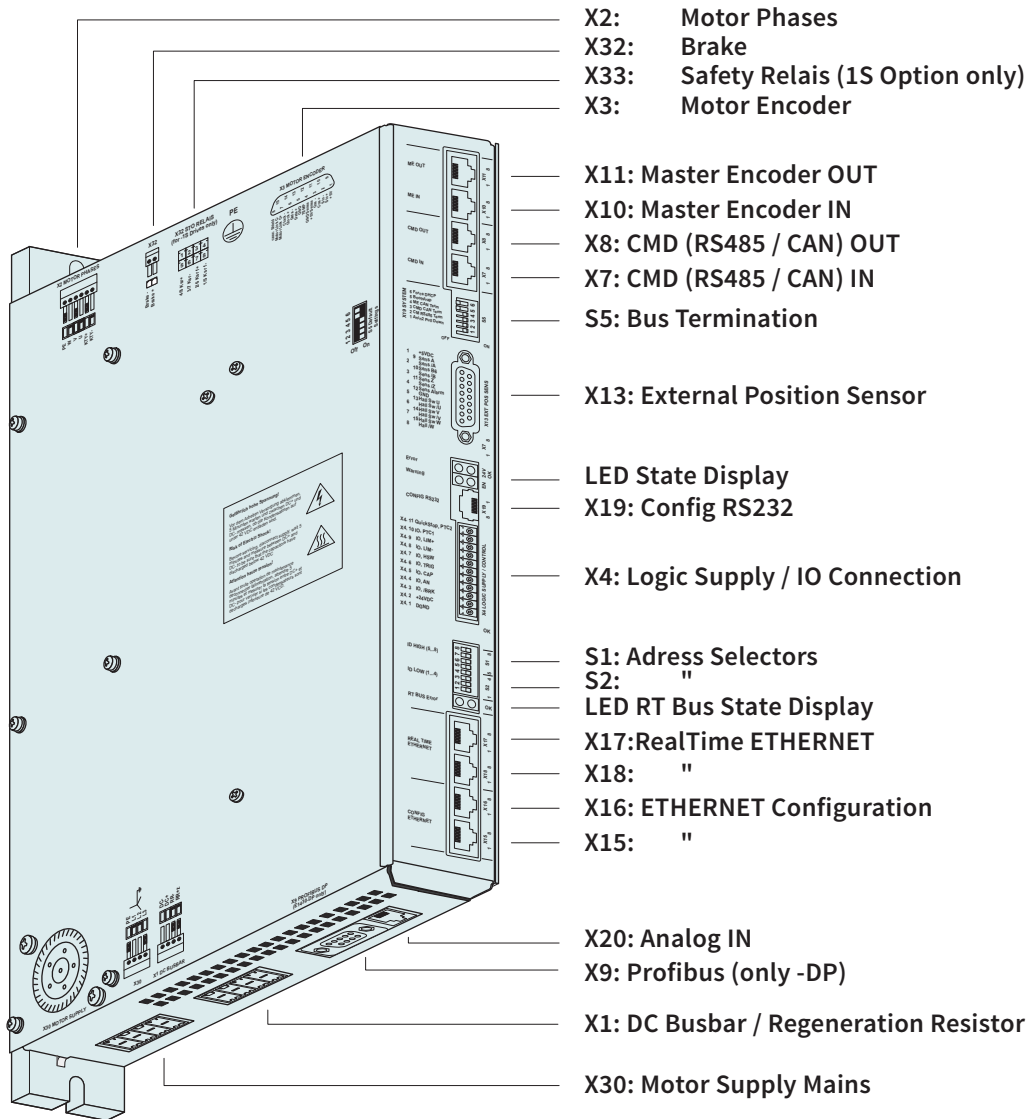

Interfaces	E1450-PL-QN	E1430-PN-QN	E1450-PD-QN	E1450-SC-QN	E1450-IP-QN	E1450-LU-QN	E1450-EC-QN	E1450-DS-QN	E1450-SE-QN	E1430-DP-QN	E1400-GP-QN
CANopen											•
LinRS											•
POWERLINK	•										
PROFINET		•									
PROFINET Profidrive			•								
SERCOS III				•							
ETHERNET IP					•						
LinUDP						•					
ETHERCAT							•				
ETHERCAT CiA402								•			
ETHERCAT SoE									•		
PROFIBUS DP										•	



- E1450-PL-QN**
- E1450-PN-QN**
- E1450-PD-QN**
- E1450-SC-QN**
- E1450-IP-QN**
- E1450-LU-QN**
- E1450-EC-QN**
- E1450-DS-QN**
- E1450-SE-QN**
- E1430-DP-QN**
- E1400-GP-QN**

- » Absolute & Relative Positioning
- » Travel Along Time Curves
- » Positioning using Motion Profiles
- » Internally stored Motion Commands
- » Internally stored Motion Sequences
- » Master Encoder Synchronization
- » Synchronization to Belt Speed
- » Position Streaming
- » Analog Position Target
- » Analog Parameter Scaling
- » Winding Function Block
- » Force Control Technology Function
- » Customer-Specific Functions

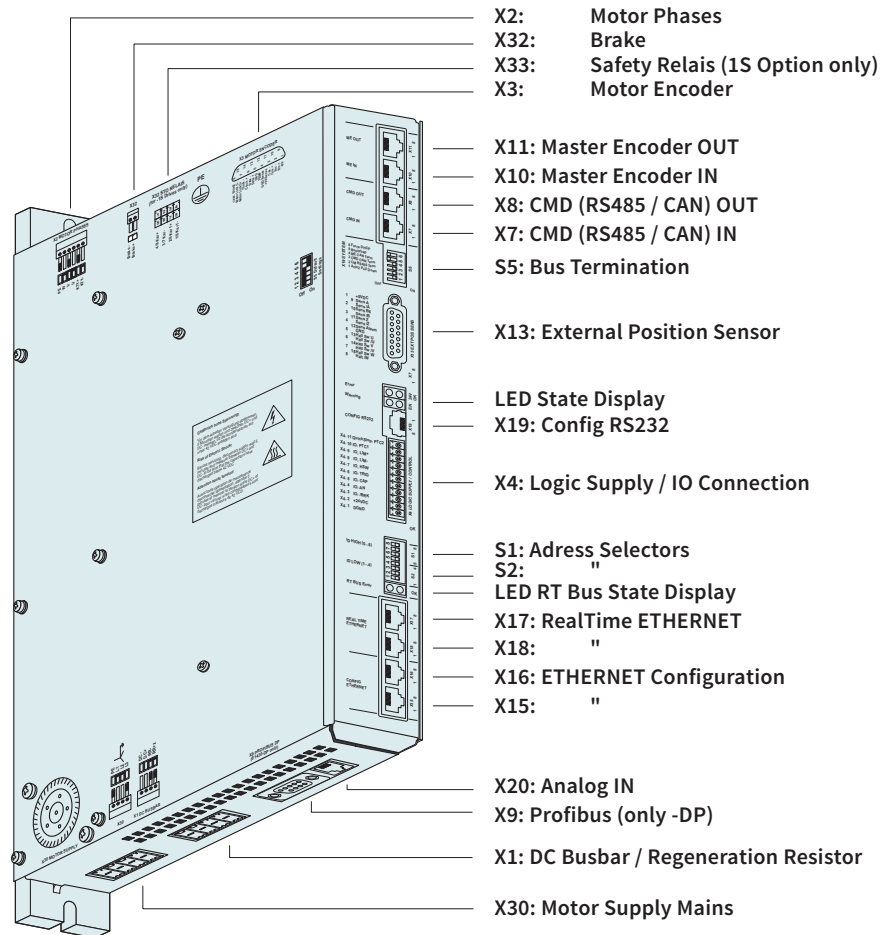

INDUSTRIAL ETHERNET

Series E1400 drives allow integration of LinMot linear motors in control concepts with industrial ETHERNET interfaces. The user can integrate Series E1400 drives regardless of the provider of the overlaid control.

LinMot drives are available with common industrial ETHERNET protocols. Since all ETHERNET drives have the same motion command interface and the control and status word are identical, software blocks that have been implemented once can be transferred to other drives without any problem.

Series E1400 Servo Drives support the following industrial ETHERNET protocols:

- » Profinet
- » ETHERNET IP
- » PowerLink
- » EtherCat
- » Sercos III
- » Profibus

The appropriate drive is available for each protocol.

TECHNICAL DATA

Type:	Realtime ETHERNET
Switch/Hub:	Integrated 2-Port Hub/Switch
Transfer rate:	10/100MBit/sec
Minimal cycle times:	
Bus cycle:	250 µs
IO update:	250 µs
Trigger Input:	125 µs
Position control loop:	125 µs
Current control loop:	125 µs

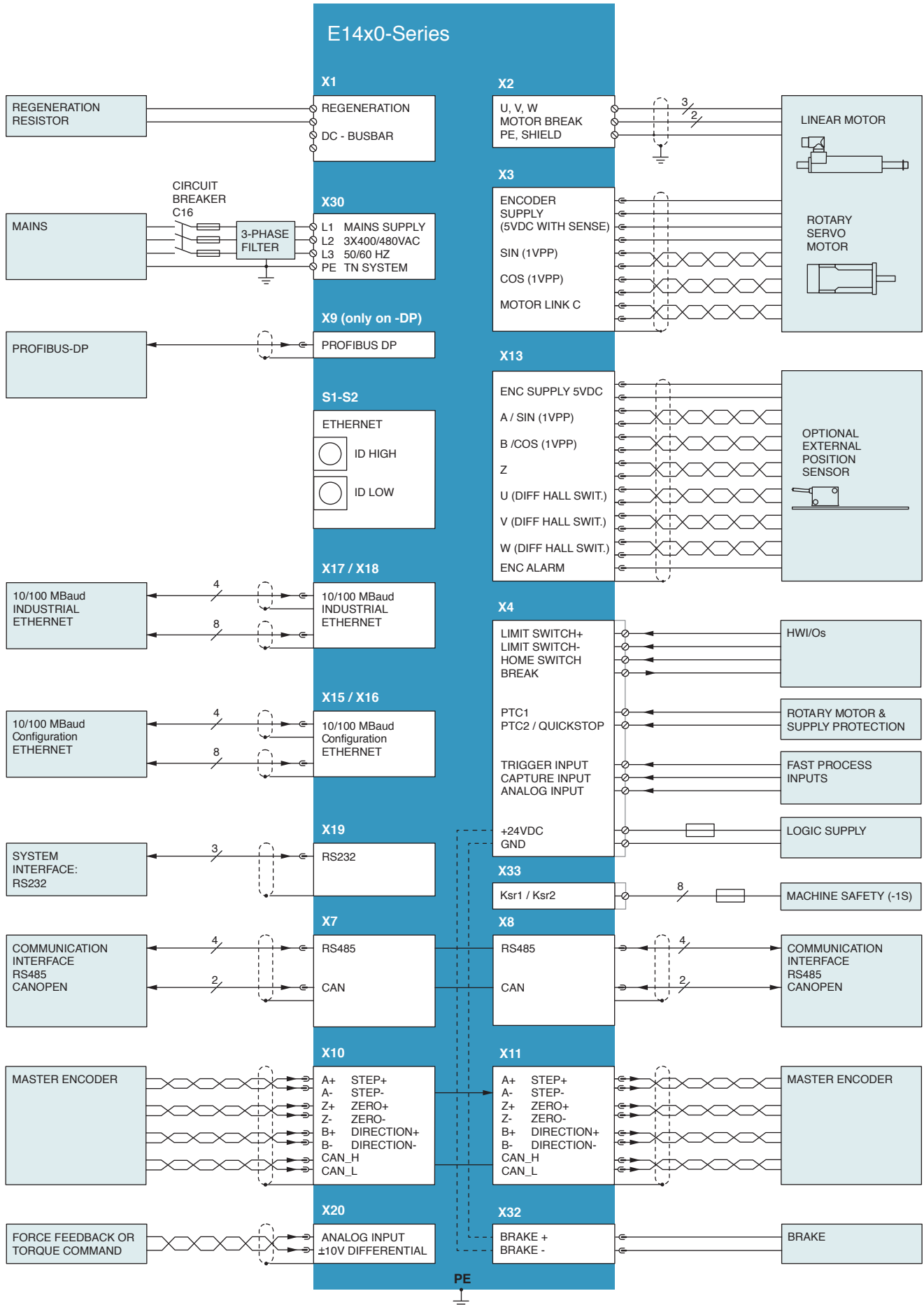

X1 DC BUSBAR / REGENERATION RESISTOR

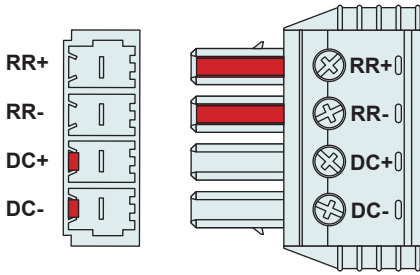

Nr	Designation
RR+	Positive connection for Regeneration Resistor
RR-	Negative connection for Regeneration Resistor
DC+	DC busbar +
DC-	DC busbar -

For coupling the DC busbar of different drives, contact support@linmot.com for additional information.



It's not allowed to power the drives through DC+ and DC-!

Screw Terminals:

- » Tightening torque: 0.7 - 0.8 Nm (6.2 – 7.0 lbin)
- » Use a cross-head screw driver (PH1)
- » Use 60/75°C copper conductors only
- » Conductor cross-section: 0.25–4 mm² (depends on Motor current)/AWG 24-12
- » Stripping length 10 mm

X30 MOTOR SUPPLY MAINS

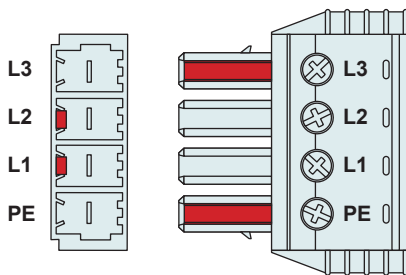

Nr	Designation
L1 - L3	3 x 400/480VAC 50/60 Hz
PE	Protective Earth

Screw Terminals:

- » Tightening torque: 0.7 - 0.8 Nm (6.2 – 7.0 lbin)
- » Use a cross-head screw driver (PH1)
- » Use 60/75°C copper conductors only
- » Conductor cross-section: 2.5–4 mm² (depends on Motor current) / AWG 24 -12
- » Stripping length 10 mm

X2 MOTOR PHASES

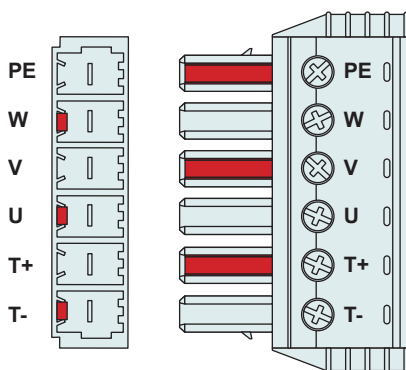

Nr	Designation
PE	Protective Earth
W	Motor Phase W
V	Motor Phase V
U	Motor Phase U
T+	Temperature Sensor KTY+ (on DC- voltage level!)
T-	Temperature Sensor KTY- (on DC- voltage level!)

The Shield of the motor cable has to be mounted with a surface as large as possible (low ohm, low impedance). Use an EMC shield clamp for fixing.



Attention:
An isolated thermistor is necessary! Especially LinMot D01 and D02 Motors can not be connected!

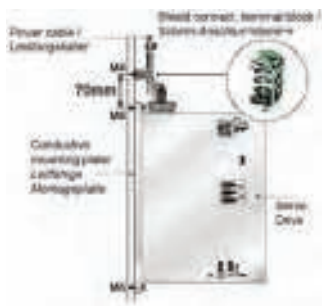

Screw Terminals:

- » Tightening torque: 0.7 - 0.8 Nm (6.2 – 7.0 lbin)
- » Use a cross-head screw driver (PH1)
- » Use 60/75°C copper conductors only
- » Conductor cross-section: 0.25–4 mm² (depends on Motor current)/AWG 24 -12
- » Stripping length 10 mm

X32 MOTOR BRAKE

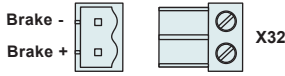

Brake -
Brake +
The brake is powered internally by 24VDC from X4! It's suitable for driving inductive loads up to 1.5A (preliminary). The V1 Drives had a separate connector for the brake supply (X31).

X3 MOTOR ENCODER (MOTOR LINK C)

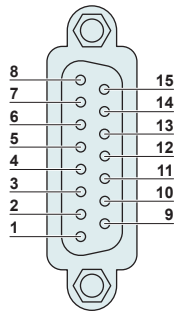

DSUB-15 (m)

Nr	Description
8	Motor Link C-
15	Motor Link C+
7	do not connect
14	do not connect
6	do not connect
13	do not connect
5	GND
12	do not connect
4	GND Sense
11	+5V Sense
3	Cos-
10	Cos+
2	Sin-
9	Sin+
1	+5V
Case	Shield

Motor Link C is a high speed serial communication protocol to the motor encoder

X4 LOGIC SUPPLY / IO CONNECTION

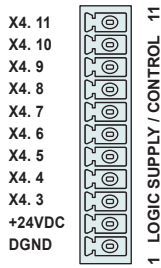

Spring cage connector

Nr	Description		
11	Input	Quickstop	Quickstop, PTC2 Input
10	I/O	X4.10	Configurable IO, PTC 1 Input
9	I/O	X4.9	Configurable IO
8	I/O	X4.8	Configurable IO
7	I/O	X4.7	Configurable IO, Analog Input for EasySteps Application
6	I/O	X4.6	Configurable IO, Trigger Input
5	I/O	X4.5	Configurable IO
4	I/O	X4.4	Configurable IO, Analog Input (configurable as high imp. Input)
3	I/O	X4.3	Configurable IO
2	+24VDC	Supply	Logic Supply 22-26 VDC
1	GND	Supply	Ground

Inputs (X4.3 .. X4.11): shortcut 24V / 5mA (Low Level: -0.5 to 5VDC, High Level: 15 to 30VDC)
Outputs (X4.3 .. X4.10): 24V / max.100mA, Peak 370mA (will shut down if exceeded)

Supply 24V / type. 1A / max. 2.5A (if all outputs “on” with max. load.)

- » Use 60/75°C copper conductors only
- » Conductor cross-section max. 1.5 mm²
- » Stripping length: 10 mm

X33 SAFETY RELAYS (ONLY WITH THE -1S OPTION)

X33. 4/8 Ksr+
 X33. 3/7 Ksr-
 X33. 2/6 Ksr f+
 X33. 1/5 Ksr f-

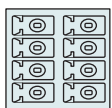

Spring cage connector

X33 STO RELAYS

Nr	Description	
4/8	Ksr +	Safety Relay 1 / 2 Input positive
3/7	Ksr -	Safety Relay 1 / 2 Input negative
2/6	Ksr f+	Safety Relay 1 / 2 feedback positive
1/5	Ksr f-	Safety Relay 1 / 2 feedback negative



- » Use 60/75°C copper conductors only
- » Conductor cross-section max. 1.5mm² (AWG 16)
- » Stripping length: 10 mm
- » Never connect the safety relays to the logic supply of the drive!

X7-X8 CMD (RS485/CAN)

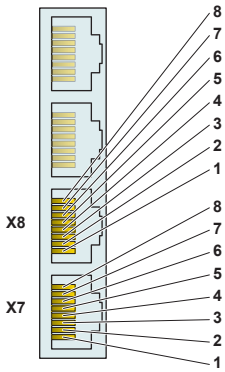

RJ-45

Nr	Description	
1	RS485_Rx+	A
2	RS485_Rx-	B
3	RS485_Tx+	Y
4	GND	
5	GND	
6	RS485_Tx-	Z
7	CAN_H	
8	CAN_L	
Case	Shield	

Use twisted pair (1-2, 3-6, 4-5, 7-8) cable for wiring.
The built in RS485 and CAN terminations can be activated by S5.2 and S5.3. X7 is internally connected to X8 (1:1 connection)

X9 PROFIBUS DP (ONLY AVAILABLE ON E1430-DP-QN)

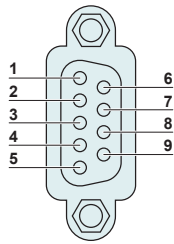

DSUB-9 (f)

Nr	Description	
1	Not connected	
6	+5V	(isolated)
2	Not connected	
7	Not connected	
3	RxD/TxD-P	
8	RxD/TxD-N	
4	CNTR-P	
9	Not connected	
5	GND	(isolated)
Case	Shield	

Max. Baud rate: 12 Mbaud

X10-X11 MASTER ENCODER IN (X10) / MASTER ENCODER OUT (X11)

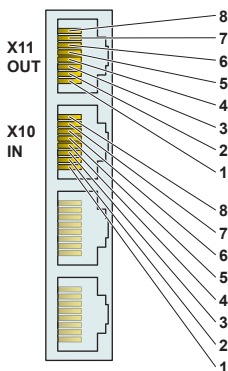

RJ-45

Nr	Incremental	Step/Direction	EIA/TIA 568A colors
1	A+	Step+	Green/White
2	A-	Step-	Green
3	B+	Direction+	Orange/White
4	Z+	Zero+	Blue
5	Z-	Zero-	Blue/White
6	B-	Direction-	Orange
7	CAN_H	CAN_H	Brown/White
8	CAN_L	CAN_L	Brown
Case	Shield	Shield	

Use twisted pair (1-2, 3-6, 4-5, 7-8) cable for wiring.

Master Encoder Inputs: Differential RS422, max. 25 M counts/s, 40ns edge separation
Master Encoder Outputs: Amplified RS422 differential signals from Master Encoder IN (X10)

The CAN bus can be terminated with S5.4.
All devices, which are connected to X10/X11 must be referenced to the same ground.

X13 EXTERNAL POSITION SENSOR DIFFERENTIAL HALL SWITCHES

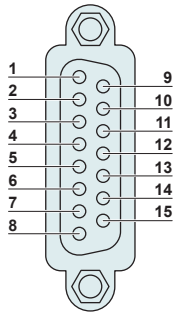

DSUB-15 (f)

Nr	Description		SSI / BiSS / EnDat	
1	+5V DC		+5V DC	
9	A+		A+	
2	A-		A-	
10	B+		B+	
3	B-		B-	
11	Z+		Data+	
4	Z-		Data-	
12	Encoder Alarm		Encoder Alarm	
5	GND		GND	
13	U+		nc	
6	U-		nc	
14	V+		nc	
7	V-		nc	
15	W+		Clk+	
8	W-		Clk-	
Case	Shield		Shield	

Position Encoder Inputs (RS422):

Encoder Simulation Outputs (RS422):

Differential Hall Switch Inputs (RS422):

Enc. Alarm In:

Sensor Supply:

Max Input Frequency: 25 M counts/s with quadrature decoding, 40ns edge separation
 Max Output Frequency: 4 M counts/s with quadrature decoding, 250ns edge separation
 Input Frequency: <1kHz
 5V / 1mA
 5VDC max. 100mA / 9VDC 100mA (SW selectable)

X15-X16 ETHERNET CONFIGURATION 10/100 MBIT/S

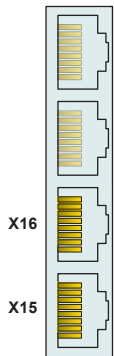

RJ-45

Nr	Description
X16	Internal 2-Port 10BASE-T and 100BASE-TX Ethernet Switch with Auto MDIX.
X15	

X17 - X18 REALTIME ETHERNET 10/100 MBIT/S

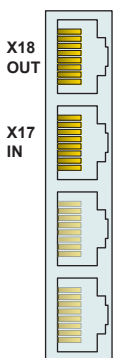

RJ-45

Nr	Description	
X18	RT ETH Out	Specification depends on RT-Bus Type. Please refer to according documentation.
X17	RT ETH In	

X19 SYSTEM

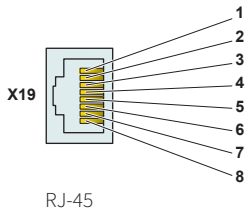

Nr	Description
1	Do not connect
2	Do not connect
3	RS232 Rx
4	GND
5	GND
6	RS232 Tx
7	Do not connect
8	Do not connect
case	Shield

Use isolated USB-RS232 converter (Art.-No. 0150-2473) for configuration over RS232.

X20 ANALOG IN (+-10V DIFFERENTIAL ANALOG INPUT)

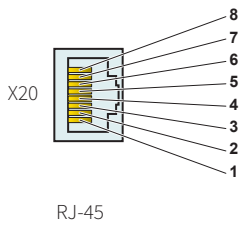

Nr	Description
1	Do not connect
2	Do not connect
3	Analog In-
4	GND
5	GND
6	Analog In+
7	Do not connect
8	Do not connect
case	Shield

S5 BUS TERMINATION / ANIN2 PULL DOWN

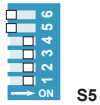

Switch	E1400
S5	Switch 6: Override Configuration Ethernet to DHCP
	Switch 5: Bootstrap: Must be off for normal operation
	Switch 4: CAN termination on ME (120R between pin 7 and 8 on X10/X11) on/off
	Switch 3: CAN termination on CMD (120R between pin 7 and 8 on X7/X8) on/off
	Switch 2: Termination resistor for RS485 on CMD (120R between pin 1 and 2 on X7/X8) on/off
	Switch 1: AnIn2 pull down (4k7 Pull down on X4.4). Set to ON, if X4.4 is used as digital output.

Factory setting: all switches “on” except S5.5 (Bootstrap) and S5.6 (Override to DHCP)

LEDS STATE DISPLAY



24VOK	Green	24V Logic Supply OK
EN	Yellow	Motor Enabled / Error Code Low Nibble
Warn	Yellow	Warning / Error Code High Nibble
Error	Red	Error

LEDS RT BUS LED



BUS OK	Green	OK
BUS Error	Red	Error

The use of these LEDs depends on the type of fieldbus which is used. Please see the corresponding manual for further information.

S1 - S2 ADDRESS SELECTORS



Switch	
S1 (5...8)	Bus ID High (0...F) Bit 5 is the LSB, bit 8 the MSB
S2 (1...4)	Bus ID Low (0...F) Bit 1 is the LSB, bit 4 the MSB

The use of these switches depends on the type of fieldbus which is used. Please see the corresponding manual for further information.

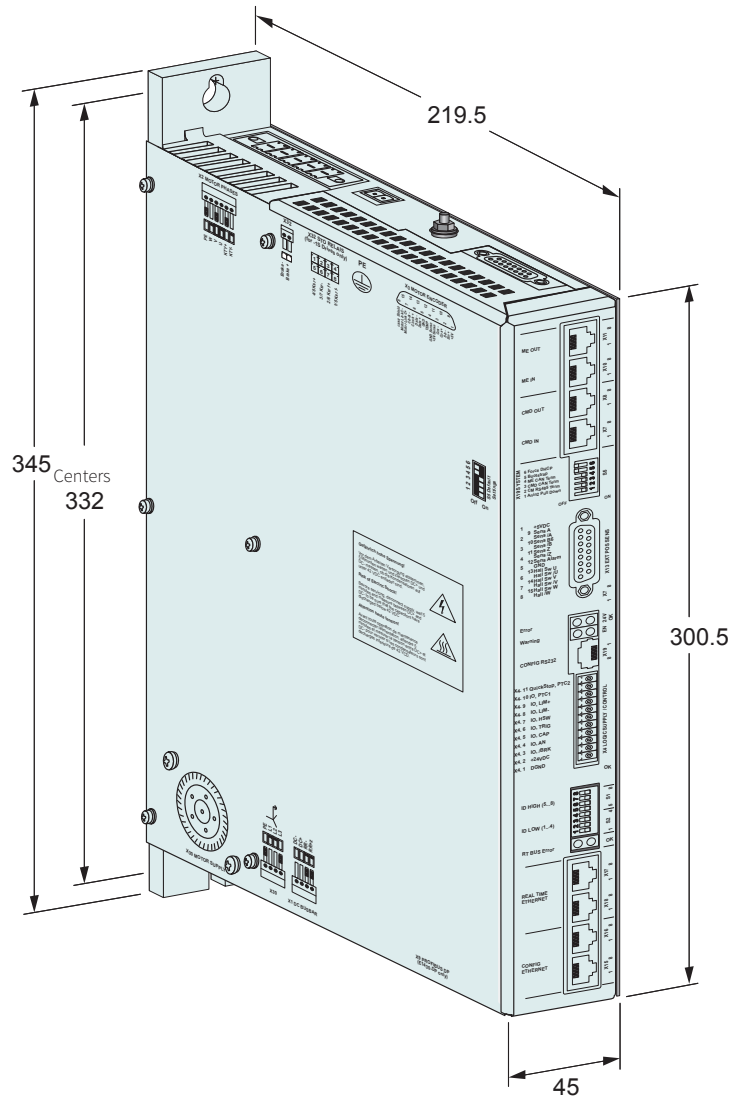

Dimensions in mm

E1400		
Width	mm (in)	45 (1.8)
Height	mm (in)	300 (11.8)
Height with fixings	mm (in)	345 (13.6)
Depth	mm (in)	219.5 (8.7)
Weight	kg (lb)	3.7 (8.2)
Mounting	mm (in)	2 x M5, Distance 332 (13.07)
Case IP Code	IP	20
Storage temperature	°C	-25...40
Transport temperature	°C	-25...70
Operating temperature	°C	0...40 at rated data 40...50 with power derating
Relative humidity		95% (non-condensing)
Pollution	IEC/EN 60664-1	Pollution degree 2
Shock resistance (16 ms)	-1S option	3.5g
Vibration resistance (10-200Hz)	-1S option	1g
Max. case temperature	°C	90
Max. power dissipation	W	100
Mounting place		In the control cabinet
Mounting position		vertical
Distance between Drives (fan cooling is integrated on V2 Drives)	mm (in)	≥ 15 (0.6) left and right ≥ 200 (8) top / bottom

Servo Drives		
Item	Description	Part Number
E1400-GP-QN-0S	GENERAL PURPOSE Drive (3x400/480VAC/ 28A / 50/60Hz)	0150-1779
E1430-DP-QN-0S	PROFIBUS-DP Drive (3x400/480VAC/ 28A / 50/60Hz)	0150-1786
E1450-DS-QN-0S	ETHERCAT CoE (3x400/480VAC/ 28A / 50/60Hz)	0150-2411
E1450-EC-QN-0S	ETHERCAT Drive (3x400/480VAC/ 28A / 50/60Hz)	0150-1784
E1450-IP-QN-0S	ETHERNET IP Drive (3x400/480VAC/ 28A / 50/60Hz)	0150-1782
E1450-LU-QN-0S	LinUDP Drive (3x400/480VAC/ 28A / 50/60Hz)	0150-2494
E1450-PD-QN-0S	PROFIdrive Drive (3x400/480VAC/ 28A / 50/60Hz)	0150-2621
E1450-PL-QN-0S	POWERLINK Drive (3x400/480VAC/ 28A / 50/60Hz)	0150-1791
E1450-PN-QN-0S	PROFINET Drive (3x400/480VAC/ 28A / 50/60Hz)	0150-1783
E1450-SC-QN-0S	SERCOS III Drive (3x400/480VAC/ 28A / 50/60Hz)	0150-1785
E1450-SE-QN-0S	SERCOS over ETHERCAT Drive (3x400/480VAC/ 28A / 50/60Hz)	0150-1899
E1400-GP-QN-1S	GENERAL PURPOSE Drive (3x400/480VAC/ 28A / 50/60Hz / STO)	0150-2351
E1430-DP-QN-1S	PROFIBUS-DP Drive (3x400/480VAC/ 28A / 50/60Hz / STO)	0150-2352
E1450-DS-QN-1S	ETHERCAT CoE (3x400/480VAC/ 28A / 50/60Hz / STO)	0150-2412
E1450-EC-QN-1S	ETHERCAT Drive (3x400/480VAC/ 28A / 50/60Hz / STO)	0150-2353
E1450-IP-QN-1S	ETHERNET IP Drive (3x400/480VAC/ 28A / 50/60Hz / STO)	0150-2354
E1450-LU-QN-1S	LinUDP Drive (3x400/480VAC/ 28A / 50/60Hz / STO)	0150-2495
E1450-PD-QN-1S	PROFIdrive Drive (3x400/480VAC/ 28A / 50/60Hz / STO)	0150-2622
E1450-PL-QN-1S	POWERLINK Drive (3x400/480VAC/ 28A / 50/60Hz / STO)	0150-2355
E1450-PN-QN-1S	PROFINET Drive (3x400/480VAC/ 28A / 50/60Hz / STO)	0150-2356
E1450-SC-QN-1S	SERCOS III Drive (3x400/480VAC/ 28A / 50/60Hz / STO)	0150-2357
E1450-SE-QN-1S	SERCOS over ETHERCAT Drive (3x400/480VAC/ 28A / 50/60Hz / STO)	0150-2358

Accessories		
Item	Description	Part Number
DC01-E1400/X4/X30	Drive Connector Set for E1400-0S	0150-3452
DC01-E1400/X4/X30/X33	Drive Connector Set for E1400-1S	0150-3453
DC01-E1400/X1	Drive Connector Regeneration / Busbar	0150-3445
DC01-E1400/X30	Drive Connector 3x400VAC Supply	0150-3449
DC01-E1400/X32	Drive Connector Brake	0150-3450