LinMot[®]

Documentation of *LinMot-Talk 5* Configuration Software



LinMot-Talk 5 User Manual

© 2012 NTI AG

This work is protected by copyright.

Under the copyright laws, this publication may not be reproduced or transmitted in any form, electronic or mechanical, including photocopying, recording, microfilm, storing in an information retrieval system, not even for didactical use, or translating, in whole or in part, without the prior written consent of NTI AG.

LinMot® is a registered trademark of NTI AG.

Note

The information in this documentation reflects the stage of development at the time of press and is therefore without obligation. NTI AG reserves itself the right to make changes at any time and without notice to reflect further technical advance or product improvement.

Document version 5.1/ October 2012

Table of Content

1 INTRODUCTION.....	4
1.1 SYSTEM GENERATIONS (SG).....	4
2 OVERVIEW.....	5
2.1 TOOL BUTTON BAR.....	6
2.2 CONTROL PANEL.....	7
2.3 MESSAGES.....	8
2.4 ERRORS.....	8
2.5 OSCILLOSCOPE.....	9
2.6 CURVES.....	10
2.7 PARAMETERS.....	11
2.8 VARIABLES.....	11
2.9 COMMAND TABLE.....	13
2.10 ACCESS CODES.....	14
3 QUICK START GUIDE.....	15
3.1 CABLING E1100.....	15
3.2 CABLING E1200.....	16
3.3 CABLING E1400.....	17
3.4 CABLING B1100.....	18
3.5 CABLING B8050-ML.....	19
3.6 FIRMWARE DOWNLOAD.....	20
3.7 LOGIN.....	20
3.8 SCANNING CAN BUS.....	21
3.9 SCANNING ETHERNET	22
3.10 MOTOR WIZARD.....	23
3.11 CONTINUOUS CURVE MODE.....	31
3.12 DEFINING CURVES.....	32
3.13 CONTROL STATUS.....	36
3.14 OSCILLOSCOPE.....	37
3.15 CONTINUOUS TWO POINT MODE.....	38
3.16 EXPORT CONFIGURATION.....	39
3.17 IMPORT CONFIGURATION.....	40
3.18 OPEN OFFLINE CONFIGURATION.....	40
3.19 CREATE OFFLINE CONFIGURATION.....	41
4 TROUBLE SHOOTING.....	42
4.1 SETTING ALL PARAMETERS TO DEFAULT VALUES.....	42
4.2 INTERFACE DOES NOT RUN.....	42
4.3 STOPPING FIRMWARE.....	42
5 CONTACT ADDRESSES.....	43

1 Introduction

The LinMot-Talk 5 software is a PC based tool, which helps the user in a comfortable way installing firmware on the drive, setting up the drive's configuration, defining and programming motion profiles, emulating the PLC, watching variables and reading messages and errors. The LinMot-Talk 5 works with the drive series B1100, E1100, E1200, E1400 and B8050. It replaces the LinMot-Talk1100 software. For the rest of this document and all other documents, the more general term "LinMot-Talk" will be used for the Linmot- PC configuration software.

1.1 System Generations (SG)

The LinMot drive families are based on different hardware platforms, which are called system generations. The abbreviation is "SG". Whereas differences of hardware of software functionality exist between the system generations, the documentation is marked with the "SG" term. The following table gives an overview of which drive family belongs to which SG:

SG	Drives
SG1	Families E400, E4000 V1
SG2	Families E400, E4000 V2
SG3	Family E1100 (GP, CO, DN, DP) (LC/HC/XC)
SG4	Family B1100 (VF, PP, GP, ML) (LC/HC/XC)
SG5	Family E1200 (GP, PL, EC, IP, DP, PN, SC) Family E1400 (GP, PL, EC, IP, DP, PN, SC) Family B8050-ML (PL, EC, IP, PN, SC)

2 Overview

The following screen shot gives an overview of the different functions integrated in the LinMot-Talk software.

The screenshot shows the LinMot-Talk software interface with several callout boxes pointing to specific areas:

- Configuration and Setup Tools:** Points to the top-left menu area.
- Drive Selection:** Points to the top-center menu area.
- Shortcuts to Tools:** Points to the top-right menu area.
- Control/Status Window:** Points to the main control and status display area.
- Project tree window:** Points to the left sidebar showing the project structure.
- IO Panel:** Points to the bottom-left section showing digital input status.
- Motion Command Window:** Points to the bottom-center section for sending motion commands.
- Monitoring Window:** Points to the bottom-right section showing motor status and position.





















The interface includes a menu bar (File, Search, Drive, Services, Options, Window, Tools, Manuals, Help), a toolbar, and a main workspace divided into several panels:

- Control Panel:** Lists various control functions like Switch On, Safety Volt. Enable, Quick Stop, etc.
- Status Panel:** Shows operational status, status word (40F2h), and warning word (0080h).
- Monitoring Panel:** Displays connection status (Online), firmware status (Running), motor status (Switched Off), and motor position (0.00 mm).
- IO Panel:** Shows digital input status for X4.12 through X4.3.
- Motion Command Interface:** Includes fields for command category, type, and count nibble, along with a table for command details.

2.1 Tool button bar



The tool button bar is always present and consists of the following buttons (from left):

-  ➤ **Show/Hide Tree** shows or hides the project tree window.
-  ➤ **Up** sets the focus in the project tree to the parent of the selection.
-  ➤ **Toggle** toggles between the last two displayed tree branches.
-  ➤ **Import Configuration** imports a drive's configuration.
-  ➤ **Export Configuration** exports a drive's configuration. Different parts, such as parameters, variables, oscilloscope or curves, can be selected to be exported.
-  ➤ **Print** prints items like curves, parameter configurations etc.
-  ➤ **Install Firmware** Start the drive's firmware installation.
-  ➤ **Reboot** restarts the firmware on the drive.
-  ➤ **Stop** stops the firmware on the drive, used for downloading and software configuration.
-  ➤ **Blink** sends a blink LED command to the drive, which is selected.
-  ➤ **Go Offline** logs out from actual drive.
-  ➤ **Start Motor Wizard** starts the motor configuration setup wizard.
-  ➤ **Show Control Panel** switches to the control panel.
-  ➤ **Show Parameters** switches to the variables.
-  ➤ **Show Variables** switches to the variables.
-  ➤ **Show Oscilloscope** switches to the oscilloscope.
-  ➤ **Show Messages** switch to the message viewer.
-  ➤ **Show Errors** switches to error viewer.
-  ➤ **Show Curves** switches to the curve tool.
-  ➤ **Show Command Table** switches to the command table editor.
-  ➤ **Show Object Inspector** displays a window in which shows help information to each selected object.

2.2 Control Panel

The Control Panel helps the user to access directly to the control and status word of the MC Software. The drive can be commanded from the PC, thus no PLC is necessary to be used for the first commissioning.

The screenshot displays the LinMot Control Panel software interface. It is divided into several sections:

- Control Word:** Shows 16 flags (0-15) with their states (0 or 1) and a Control Word value of 003Fh. An 'Enable Manual Override' checkbox is present.
- Status Word:** Shows 16 flags (0-15) with their states (0 or 1) and a Status Word value of 40F6h. It also shows Op. Main State (00h) and Op. Sub State (00h).
- General Monitoring:** Shows Connection Status (Online), Firmware Status (Running), and Motor Status (Switched Off). It includes a motor symbol and Op. State (Not Ready to Switch On, Motor Not Homed). Actual Position is 0.00 mm, Demand Position is 0.00 mm, Force Factor is Motor not homed!, Motor Current is 0.00 A, Logic Supply Volt is 26.21 V, and Motor Supply Volt is 48.13 V.
- IO Panel:** Shows a list of X4 inputs and outputs (X4.12 to X4.3) with their states (Act/Off).
- Motion Command Interface:** Shows an 'Enable Manual Override' checkbox, movement buttons (+10 mm, -1 mm, +1 mm, +10 mm), Command Category (Most Commonly Used), Command Type (No Operation (000xh)), and Count Nibble (Toggle Bits: 0h). It includes a table for command parameters and 'Read Command' and 'Send Command' buttons.

- **Control Word** The MC software's control word can be directly written from the PC. For taking over the PC control the left check box (Enable Manual Override) must be selected. The state of each flag can be set with the right check box (Override Value). If other flags have to be altered, the override mask must be configured in the parameter tree under \Parameters\Motion Control SW\State Machine Setup\Control Word\Ctrl Word Parameter Force Mask.
- **Status Word** The status word shows the actual state of the drive's MC software status word. It is updated automatically.
- **General Monitoring** This window displays actual motor and drive information
- **IO Panel** For commissioning. The user can take control of the X4 IOs on E1100 or X14 IOs on B1100 drives.
- **Motion Command Interface** The MC software's motion command Interface can be directly accessed over this window. When enabled (Enable Manual Override switch must be set), MC commands can be selected, parametrized and sent to the drive. Because the motion command interface is, independent of the interface running on the drive, the same, the commands can be exactly tested before programming them in the PLC.

2.3 Messages

This panel reads out and shows all messages, which are logged on the drive, and displays them in chronological order. If logged in a B1100 series drive, this window does not appear, because those drives do not support message logging.

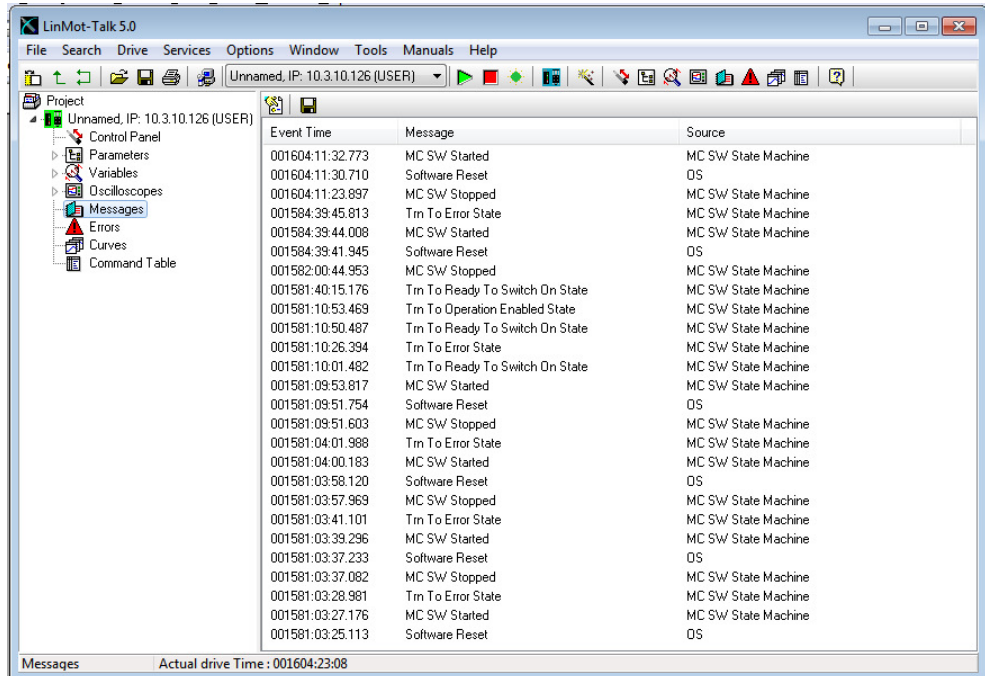

2.4 Errors

This panel reads out and shows all errors, which are logged on the drive and displays them in chronological order.

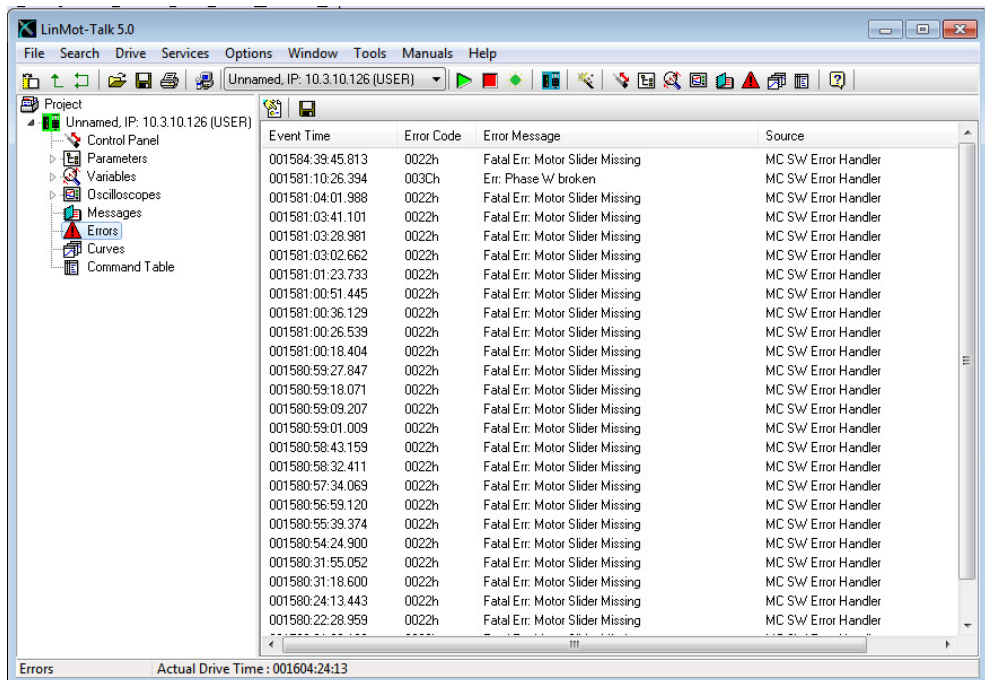

2.5 Oscilloscope

The drive's built in oscilloscope, which can record up to four channels in real time, is controlled with the oscilloscope tool.



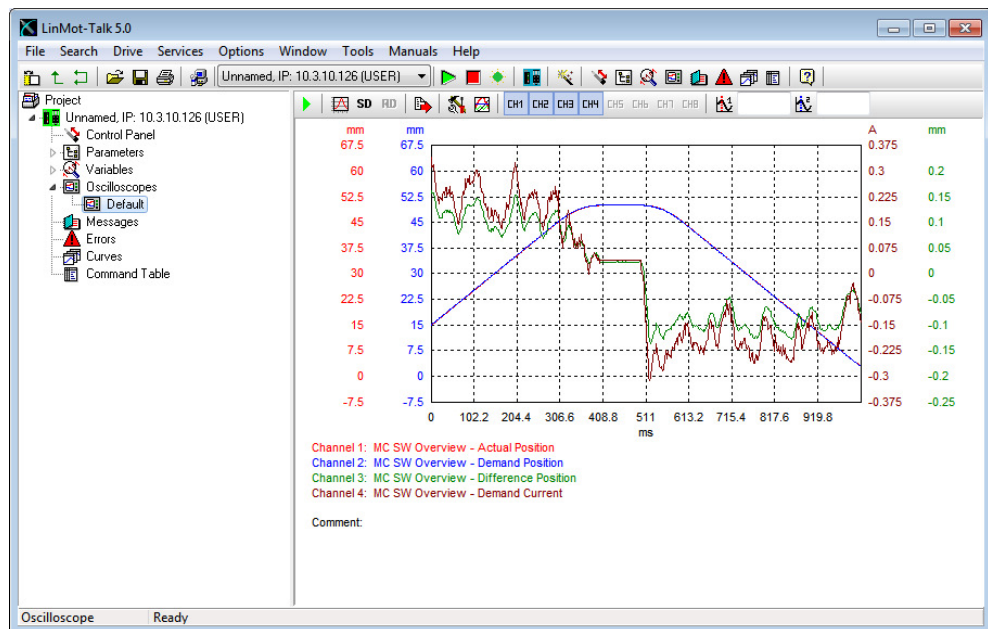



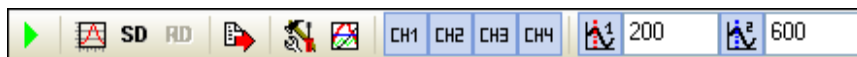

During login the oscilloscope reads out the settings and data from the drive. If an oscilloscope shot is running or ready to read out data, an item called "Read out" will be displayed. Otherwise a default item will be generated.



The oscilloscope is controlled with the buttons



The functions are (from left):

-  ➤ **Start/Abort** Start or abort an oscilloscope shot.
-  ➤ **Fit View** Displays the recorded channels such as they fit best in the scope window.
-  ➤ **Save Display** stores the settings for zoom, scaling and offset.
-  ➤ **Recall Display** restores the settings for zoom, scaling and offset, which are previously stored with Save Display.
-  ➤ **Export Data:** Export data and setups of the last recorded oscilloscope shot in a csv file.
-  ➤ **Oscilloscope Settings** Switch to setup mask for channels, triggers, times and modes.
-  ➤ **Display Settings** is used to set scale, offset and color for the oscilloscope channels.
-  ➤ **Show/Hide:** Show and hide the oscilloscope channels.
-  ➤ **Show/Hide Cursor:** Two time cursors can be displayed for measuring the signals.



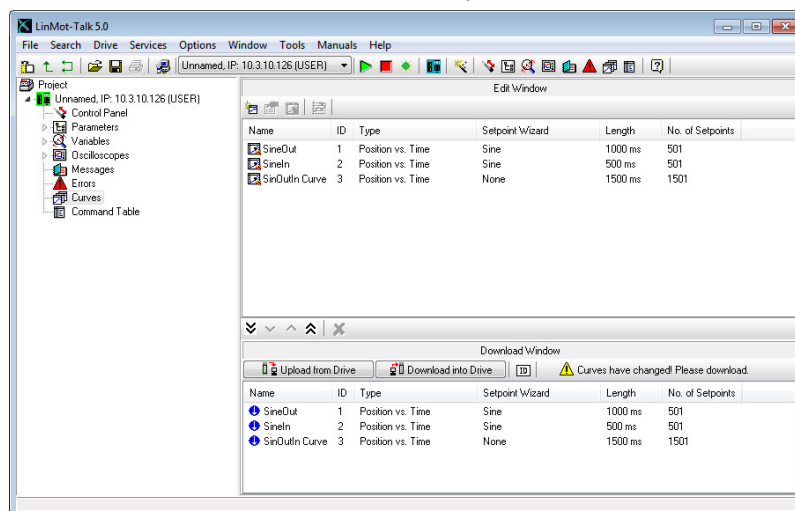

2.6 Curves

With the curve tool, motor motion profiles can be easily created, joined, uploaded, downloaded and saved. NOTE: On B1100 the curve feature must be enabled with an access key.





The curve tool is divided into the edit and the download window. The edit window is used to generate, merge and modify curves with the following buttons:



-  ➤ **New Curve** Starts the curve wizard, which guides through the curve generation.
-  ➤ **Edit Properties** The properties of a selected curve, like name, time or stroke, can be modified.
-  ➤ **Edit Curve Values** The curve points can be manually edited.
-  ➤ **Join Curves** All selected curves are joined. A wizard will be started for defining the curve properties of the joined curve.

The download window is used to manage the curves, which are stored on the drive or have to be downloaded. Modifications in this window will show up the message “Curves have changed! Please download.” After pressing the download into Drive button the window and the drive will be synchronized.



-  ➤ **Upload Curves from Drive** All curves stored on the drive will be uploaded and displayed.
-  ➤ **Download Curves to Drive** The drive’s curve sector will be synchronized with the download window.
-  ➤ **Auto Numerate Curves** The curve ID, which must be unique, will be set automatically.

The maximum number of curves and number of sample points is defined as follows:

Series E1100, E1200, E1400:

$$\#Curves * 70Bytes + \#SamplePoints^1 * 4Bytes \leq 65280Bytes$$

Series B1100:

$$\#Curves * 70Bytes + \#SamplePoints * 4Bytes \leq 2016Bytes$$

¹ #SamplePoints: total of sample points in all curves.

2.7 Parameters

The drive's parameters are displayed in a tree view.

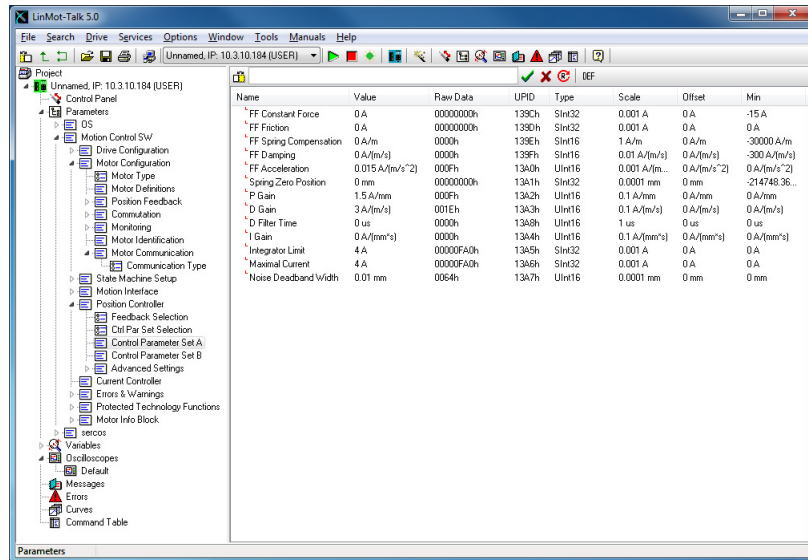

Parameters, which are marked as live (), can be altered while the drive's firmware is running; other parameters can only be changed when the software is stopped.





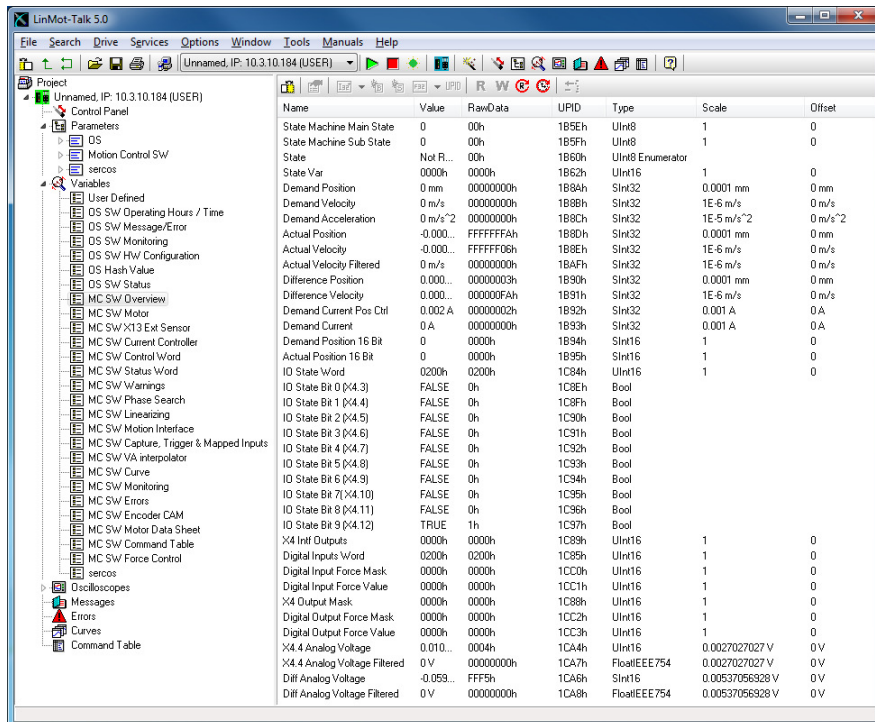

2.8 Variables

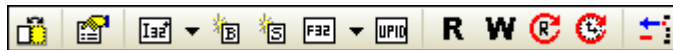
The drive's variables, which can be watched, are arranged in different functional groups. The MC SW overview group contains the most used variables.









The variable service is controlled with the following buttons:



-  ➤ **Show/Hide Details** Additional information for each parameter, such as unique parameter ID (UPID), scaling, min/max value, can be displayed on demand.
-  ➤ **Read Variable:** Reads the selected variable from the drive once.
-  ➤ **Write Variable:** Writes the selected variable to the drive.
-  ➤ **Read All Variables:** Reads from the drive all variables of the section once.
-  ➤ **Read All Variables Cyclically:** Reads from the drive all variables of the section cyclically.
-  ➤ **Remove (Del):** Removes the selected variable from the list.

The following buttons are only used in special cases.

-  ➤ **Edit Properties** The parameter properties can be displayed and changed.
-  ➤ **New ... Variable** In a new generated variable section a new variable can be defined. This is a drop down menu, which supports different variable types.
-  ➤ **New Bit Variable** In a new generated variable section a variable of the type bit can be defined.
-  ➤ **New String Variable** In a new generated variable section a variable of the type string can be defined.
-  ➤ **New Float32** In a new generated variable section a variable of the type float32 can be defined.
-  ➤ **New With UPID** In a new generated variable section a variable can be added by using the UPID from the appropriate parameter.

Under “User Defined” any variables or parameters can be arranged together. Typically the variables are selected via UPID. It is also possible to drag and drop them from the parameter or variable section.

2.9 Command Table

The drive supports the command table (CT) functionality, which means a set of up to 255 motion commands (31 commands for B1100GP and B1100VF series drives, on B1100PP CT is not supported) can be stored in this table.

An example of is shown in the following picture:

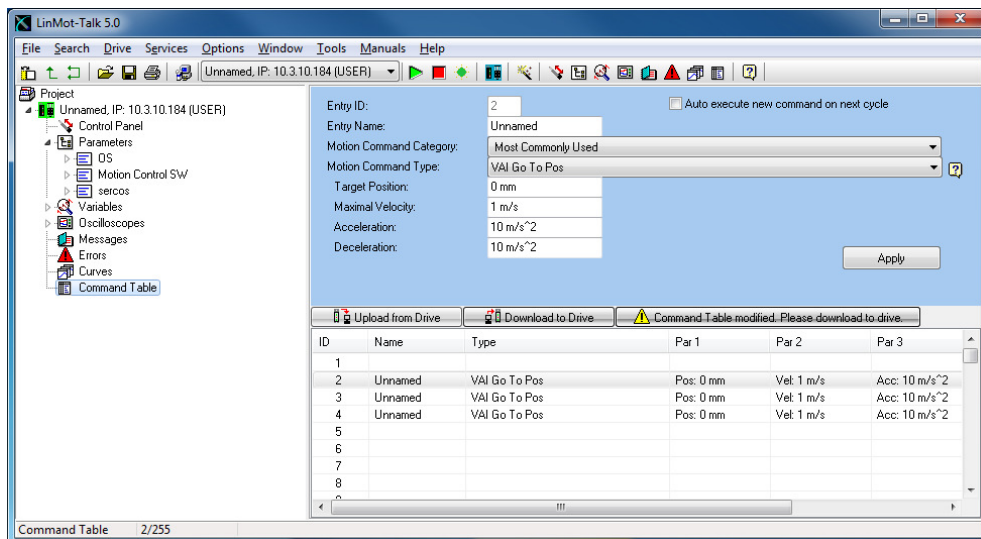

A big variety of commands can be set in this tables, such as motion commands, conditions, sequence directives, parameter access, ... This makes the CT to very powerful functional unit. The CT entries can be accessed (executed) via digital inputs (on X6) or via interface software. The CT tool has the following editing elements:

- **Entry ID** indicates the CT entry, which is being edited.
- **Entry Name** is a descriptive string of max. 16 characters
- **Motion Command Category** the available commands are fitted into groups for keeping a better overview
- **Motion Command Type** specifies the command to be executed in this entry.
- **Auto execute new command on next cycle** when selected, on the next cycle the entry specified under "ID of Sequenced Entry" will be executed. This gives the possibility of defining cycles, simple logical sequences.
- **ID of Sequenced Entry** defines the CT entry executed on the next cycle when "Auto execute new command on next cycle" is activated.
- **Apply** writes the edited values into the entry.
- **Upload from Drive** reads and displays the entire command table from the drive.
- **Download to Drive** writes the edited table (from the PC) to the drive.

An application example of the CT can be found in the motion control software user manual (Usermanual_MotionCtrlSW_E1100.pdf).

2.10 Access Codes

On the drive special features or customer specific applications can be protected by a software key. This means, a key must be activated by an access code, which is drive specific (pinned to the serial number). Under Drive\Set Access Code\ the following window will open:

The screenshot shows a window titled "Set Access Code" with a close button (X) in the top right corner. The window is divided into two main sections. The first section, "Active Keys:", contains a table with three columns: "Name", "Value", and "Access Code". The table lists four keys: Key1 (5A93h - Force Closed Loop Control, 58328193h), Key2 (0000h - No Key), Key3 (0000h - No Key), and Key4 (0000h - No Key). The second section, "Set Key Access Code:", has three input fields: "Name:" (a dropdown menu showing "Key2"), "Value (HEX):" (a text box containing "5a92"), and "Access Code (HEX):" (a text box containing "583C6B91"). To the right of these fields is a "Write" button. Below the input fields is a note: "Note: The keys will not be activated on the controller until a reboot has been processed. Press the 'activate' button to reboot." At the bottom of the window are two buttons: "Activate" and "Close".

Name	Value	Access Code
Key1	5A93h - Force Closed Loop Control	58328193h
Key2	0000h - No Key	
Key3	0000h - No Key	
Key4	0000h - No Key	

Set Key Access Code:

Name: Value (HEX): Access Code (HEX):

Note: The keys will not be activated on the controller until a reboot has been processed. Press the "activate" button to reboot.

A maximum of four keys can be set on the drive. Under Active Keys all valid installed keys are listed (key value and access code).

A new key can be set by selecting the key name and defining the value and access code. With the write button, the key and access code are written to the drive. As soon as the drive has rebooted (click the Activate button) the new key will be active, if the access code fits.

Please note: Access codes are drive specific. They cannot be copied from one drive to another.

3 Quick Start Guide

This chapter helps step by step to set up a system using servo drive and the LinMot-Talk configuration software.

3.1 Cabling E1100

The following picture shows the connectors on the drive used for a first commissioning (with PC only).

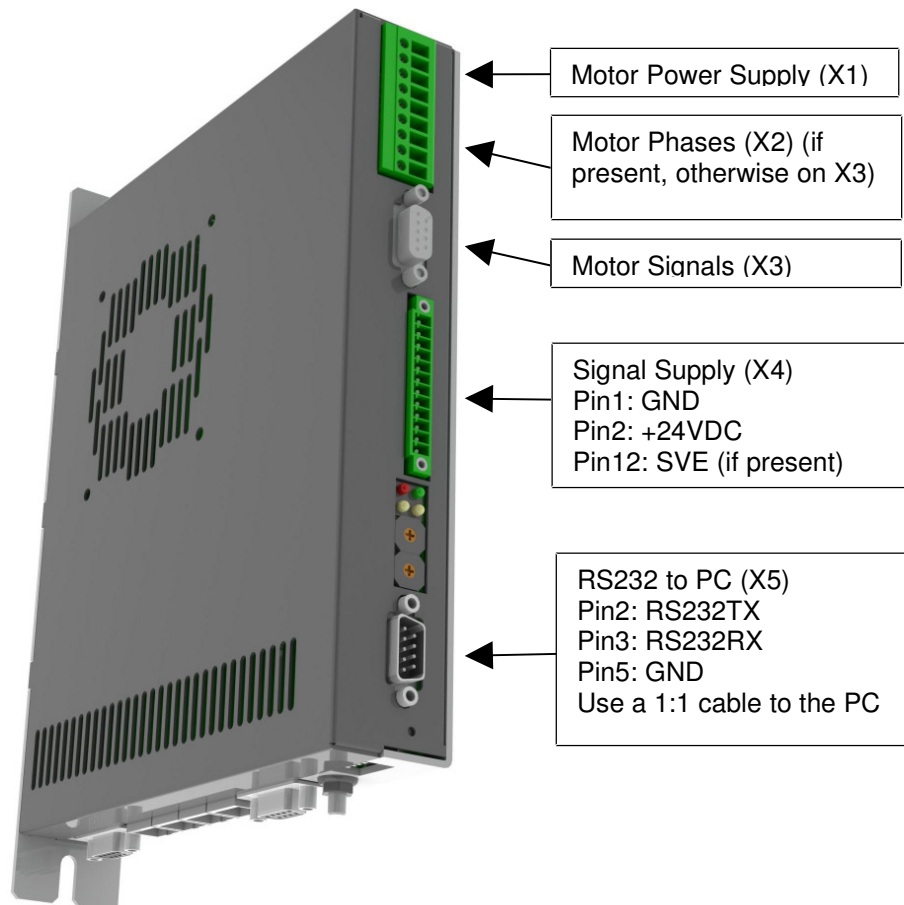

- **X1** Motor Supply, use 48..72 VDC (between PWR+ and PGND).
- **X2** Motor Phases: if this connector is not present, connect the motor on X3 only.
- **X3** Motor signals: if motor has a DSUB-9 connector, connect it directly, otherwise use an adapter to DSUB-9 or wire the phase lines to X2.
- **X4** For a commissioning with the PC it is necessary to wire only the Pin1 (GND), Pin2 (+24VDC) and, if present, Pin12 save voltage enable (SVE, +24VDC).
- **X5** RS232: The cable between the LinMot drive and PC must be DSUB-9 F/F, 1:1 (X modem). If the PC has no COM port available, use the USB to RS232 converter (LinMot article number 0150-3110).

3.2 Cabling E1200

The following picture shows the connectors on the drive used for a first commissioning (with PC only).

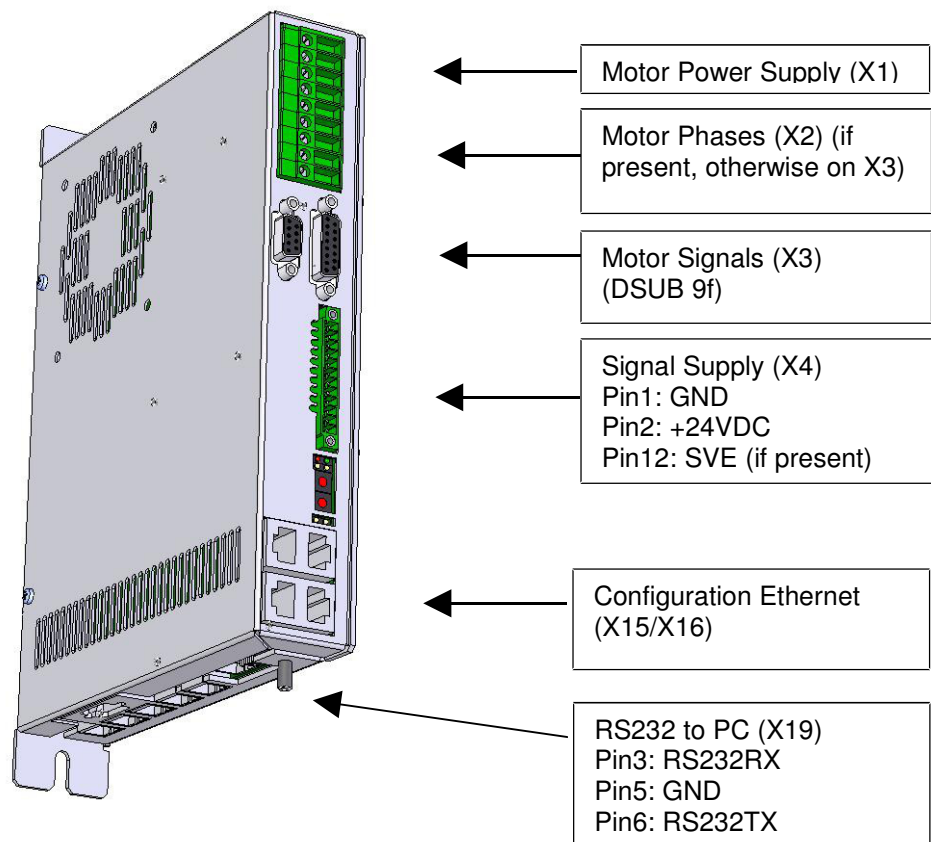

- **X1** Motor Supply, use 48..72 VDC (between PWR+ and PGND).
- **X2** Motor Phases.
- **X3** Motor Signals. (Note: the motor phases are not present on this connector. Thus wire the motor phases in any case to X2).
- **X4** For a commissioning with the PC it is necessary to wire only the Pin1 (GND), Pin2 (+24VDC) and, if present, Pin12 save voltage enable (SVE, +24VDC).
- **X15/X16** Ethernet: Use a standard RJ45 patch cable to wire to the LAN.
- **X19** RS232: Use Adapter cable AC01-RJ45/Df-2.5-RS1 (LinMot article number 0150-2143) to connect your PC via RS232. If the PC has no COM port available, use the USB to RS232 converter (LinMot article number 0150-3110).

3.3 Cabling E1400

The following picture shows the connectors on the drive used for a first commissioning (with PC only).

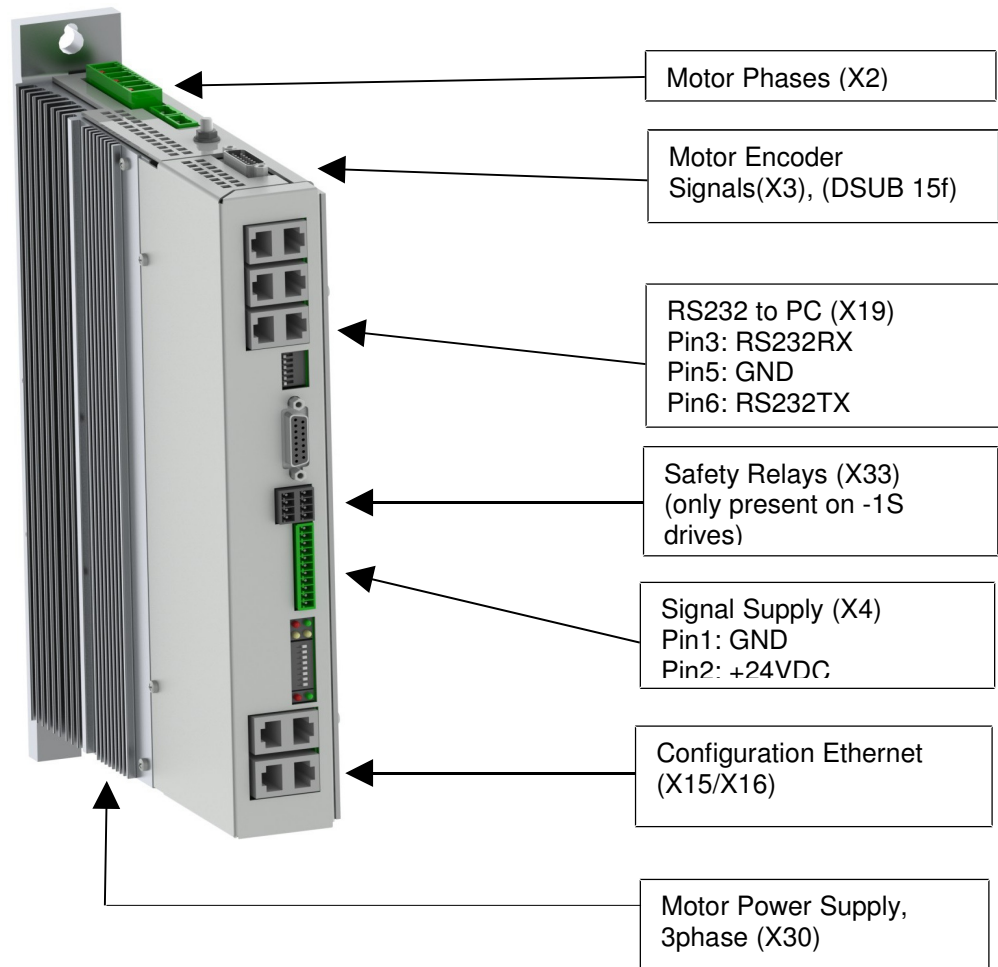

- **X2** Motor Phases.
- **X3** Motor Encoder Signals.
- **X4** For a commissioning with the PC it is necessary to wire only the Pin1 (GND) and Pin2 (+24VDC).
- **X15/X16** Ethernet: Use a standard RJ45 patch cable to wire to the LAN.
- **X19** RS232: Use Adapter cable AC01-RJ45/Df-2.5-RS1 (LinMot article number 0150-2143) to connect your PC via RS232. If the PC has no COM port available, use the USB to RS232 converter (LinMot article number 0150-3110).
- **X30** Motor Supply, use 3x400 / 3x480VAC 50/60 Hz
- **X33** Safety Relays: For the safety relays use a separate +24VDC supply. For a commissioning it is necessary to wire both Ksr+ (X33.4 and X33.8) to +24 VDC and both Ksr- (X33.3 and X33.7) to GND.

3.4 Cabling B1100

The following picture shows the connectors on the drive used for a first commissioning (with PC only).

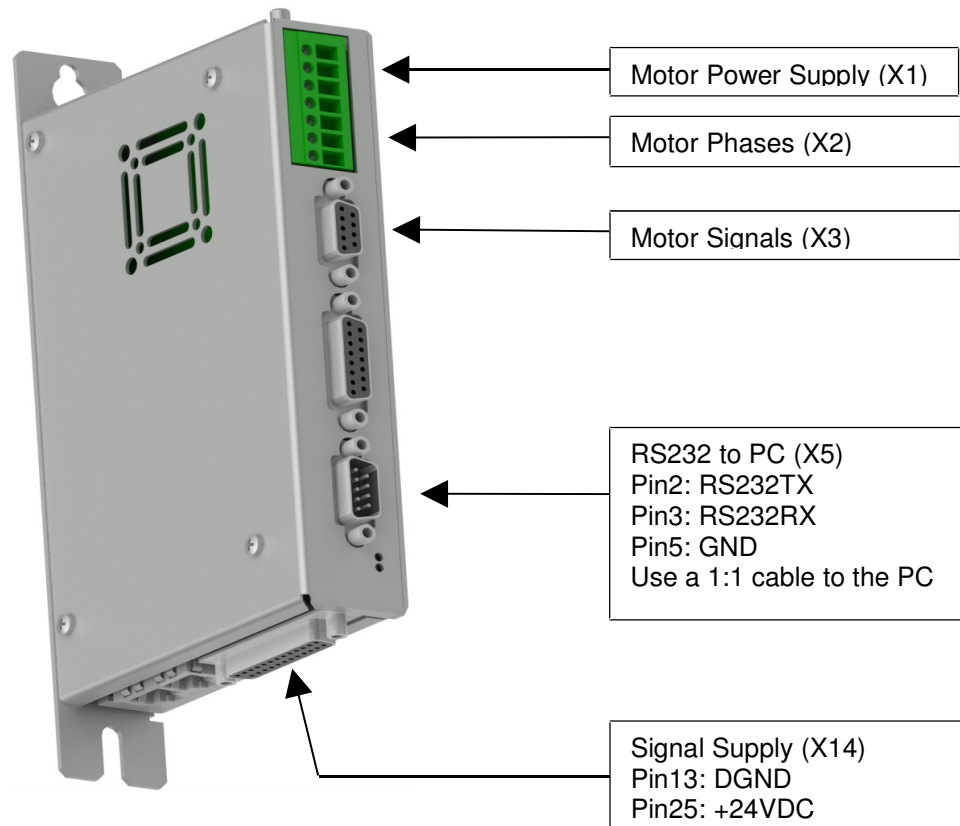

- **X1** Motor Supply, use 48..72 VDC between (PWR+ and PGND).
- **X2** Motor Phases
- **X3** Motor signals: if motor has a DSUB-9 connector, connect it directly, otherwise use an adapter to DSUB-9 or wire the phase lines to X2.
- **X5** RS232: The cable between the LinMot drive and PC must be DSUB-9 F/F, 1:1 (X modem). If the PC has no COM port available, use the USB to RS232 converter (LinMot article number 0150-3110).
- **X14** For a commissioning with the PC it is necessary to wire only the Pin13 (DGND) and Pin25 (+24VDC).

3.5 Cabling B8050-ML

The following picture shows the connectors on the drive used for a first commissioning (with PC only).

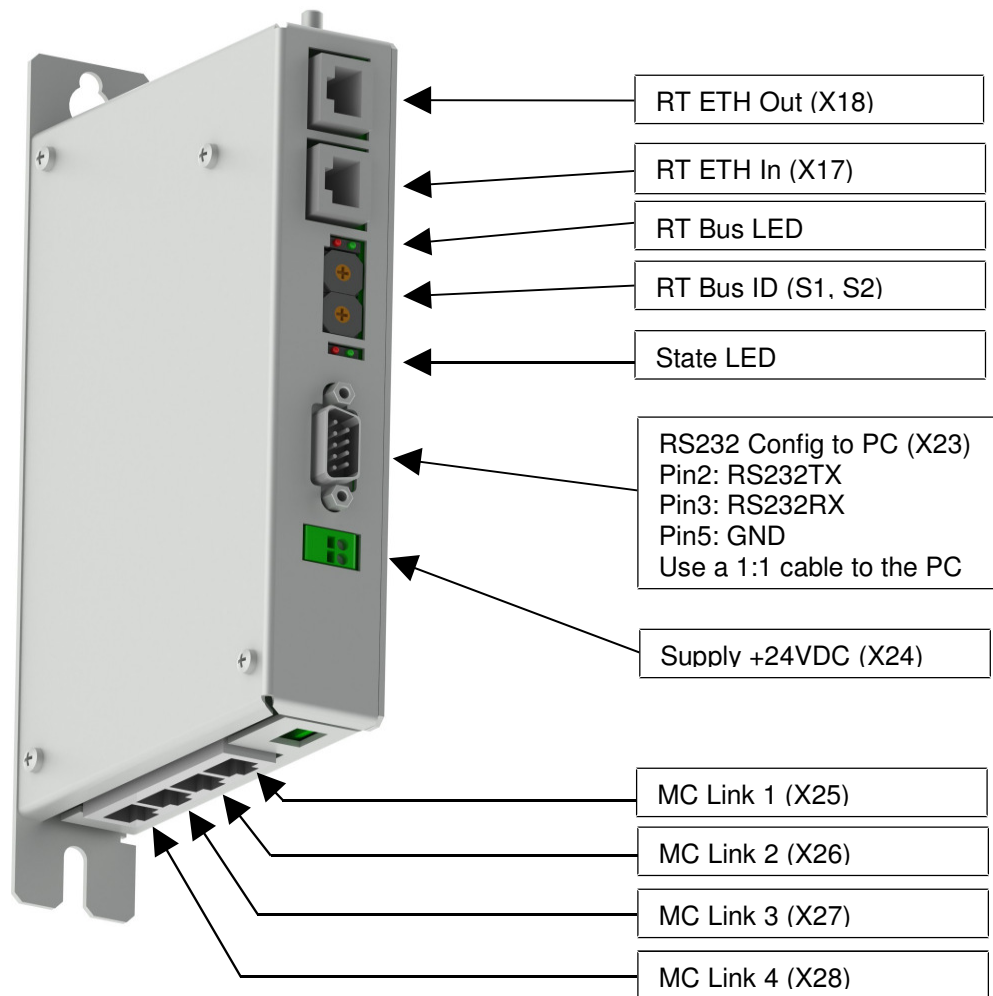

- **X23** RS232: The cable between the LinMot drive and PC must be DSUB-9 F/F, 1:1 (X modem). If the PC has no COM port available, use the USB to RS232 converter (LinMot article number 0150-3110).
- **X24** Use a 24V switched power supply.

3.6 Firmware Download

As the cabling is done correctly now, turn on the drive's power and start up the LinMot-Talk software. Before using the drive the first time, the firmware has to be downloaded. Therefore press install firmware button  to start the wizard. Choose the file "Firmware_Build20101126.sct" (or similar) and press "Open". Then the wizard will start and guide through the installation. In case of installing the firmware over ETHERNET, the service password is required. This is for safety reasons. Especially if there are a lot of drives accessible in the network, it can easily happen to confound them. Thus it is strongly recommended to set a password. By default no password is set. If the password is unknown, the parameters can be set to default by hex switches, see 4.1 "Setting all Parameters to Default Values". According to the drive type, different interface and application software can be selected.

3.7 Login

When successfully finished downloading the firmware, login with \File>Login..., then select the appropriate port and press ok. A login info window will appear showing the login progress. When logged in you will find the following window:

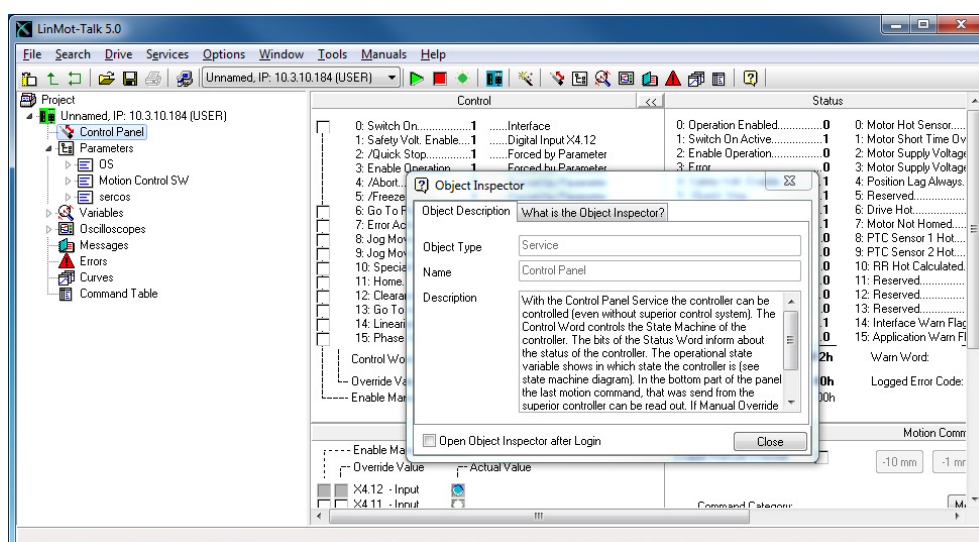

The Object Inspector window can be dragged away or closed. It can be reopened with F1.

3.8 Scanning CAN Bus

When one or several drives are linked with CAN bus for configuring, it can be very helpful to scan the CAN bus for linked drives automatically. Thus, it is not necessary to know all node IDs. Under \File\Scanning (with CANusb) a list of the present drives will be displayed:

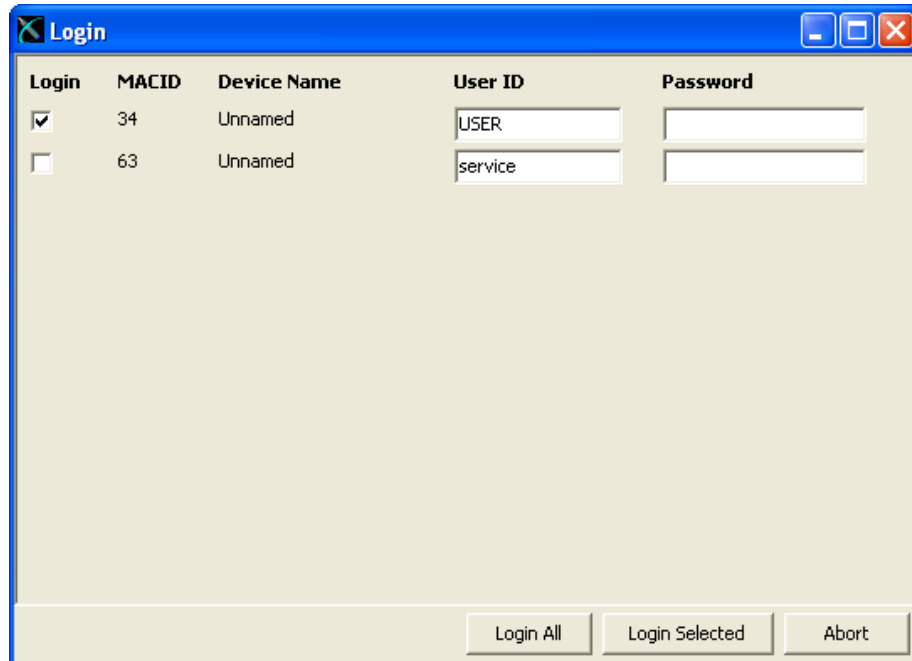

With just one click the LinMot-Talk software will log in to all drives.

3.9 Scanning Ethernet

When one or several drives are linked with Ethernet for configuring, it is helpful to scan the automatically for linked drives. Thus, it is not necessary to know all node IP addresses. Under \File\Scanning (via Ethernet) first the interface has to be selected (network link)

With the radio button Group Number could be activated a scan for a special drive group. The list will only display the drives with the group number, like the number in the text field. In the drives this number is saved in the parameter with the name Net Group and the UPID 0078h.

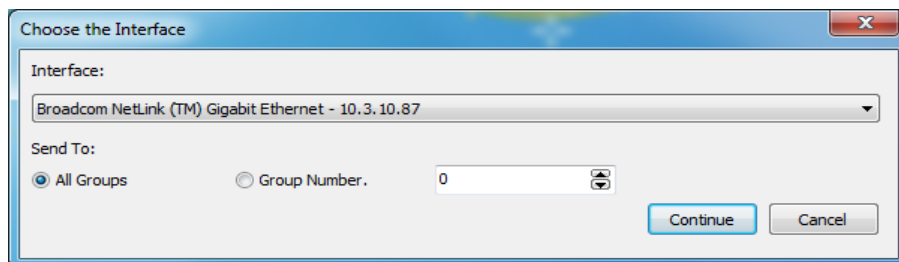

A list of the present drives will be displayed:

State	IP Address	MACID	Group	Device Name	Device Type	Release Info	User ID	Password
	10.3.10.22	00:1A:HE:00:10:5C	0	Lagertest1	E1400-GP-QN /IRB	4.4 Build 20120130	USER	
	10.3.10.61	00:1A:HE:00:1A:5C	0	Flo's E1250-SC	E1250-SC-UC/V IRE	4.4 Build 20120130	USER	
	10.3.10.66	00:1A:HE:00:0A:AA	0	KMT Referenzantrieb		4.3 Build 20110901	USER	
	10.3.10.67	00:1A:HE:00:0D:80	0	MotEnd		4.2 Beta 20110211	USER	
	10.3.10.82	00:1A:HE:00:05:0C	0	Flo's E1250-PL	E1250-PL-UC/V IRD	4.4 Build 20120130	USER	
	10.3.10.93	00:1A:HE:00:02:2A	0	MM_E1250_EC_UC	E1250-EC-UC/V IRC	5.0 Beta 20120514	USER	
	10.3.10.106	00:1A:HE:00:10:14	0	MM_E1450_SC	E1450-SC-QN /IRB	5.0 Beta 20120514	USER	
	10.3.10.107	00:1A:HE:00:22:2C	0	KHS Teststand	E1400-GP-QN /IRD	5.0 Beta 20120514	USER	
	10.3.10.108	00:1A:HE:00:06:78	0	Flo's E1250-IP	E1250-IP-UC/V IRE	4.4 Build 20120130	USER	
	10.3.10.109	00:1A:HE:00:02:48	0	Ludo Desk	E1200-GP-UC/V IRC	4.4 Build 20120130	USER	
	10.3.10.123	00:1A:HE:00:10:0C	0	Unnamed	E1450-IP-QN /IRB	5.0 Beta 20120514	USER	
	10.3.10.127	00:1A:HE:00:2B:08	0	Unnamed	E1250-PN-UC/V IRE	5.0 Beta 20120702	USER	
	10.3.10.129	00:1A:HE:00:1B:88	0	Laser3 - Laser_X	E1250-EC-UC/V IRE	4.4 Build 20120130	USER	
	10.3.10.132	00:1A:HE:00:1B:8A	0	Laser3 - Laser_Z	E1250-EC-UC/V IRE	4.4 Build 20120130	USER	
	10.3.10.137	00:1A:HE:00:02:24	0	MM_E1250_PL_UC	E1250-PL-UC/V IRC	4.4 Build 20120130	USER	
	10.3.10.143	00:1A:HE:00:22:30	0	QS_TestCtr	E1400-GP-QN /IRD	5.0 Beta 20120514	USER	
	10.3.10.179	00:1A:HE:00:12:0A	0	Unnamed	E1400-GP-QN /IRB	4.4 Build 20120130	USER	
	10.3.10.184	00:1A:HE:00:03:4E	0	Unnamed	E1250-SC-UC/V IRD	5.0 Build 20120710	USER	
	10.3.10.186	00:1A:HE:00:10:24	0	Unnamed	E1450-EC-QN /IRB	4.4 Build 20120130	USER	
	10.3.10.191	00:1A:HE:00:10:40	0	laperfert3	F1400-GP-QN /IRB	4.4 Build 20120130	IKSP	

With just one click the LinMot-Talk software will log in to all drives. The colored markings have the following meaning:

- Green: The drive is ready to log in.
- Grey: You are already logged into this drive.
- Red: Another instance is logged into this drive (other user or other interface).

The default mode for acquiring an IP address is via DHCP. If no servers on the connected network respond, the drive switches to the Ipv4 Link-Local addressing scheme (also known as APIPA on Windows systems). This way the drive automatically assigns itself an address within the range of 169.254.0.1 through 169.254.255.254 (Subnet Mask 255.255.0.0).

Please note that this process can take up to a minute until a valid address is assigned to the drive this way.

3.10 Motor Wizard

As no motor is defined, the next step is to start the motor setup wizard. Press the button  and the following window will appear:

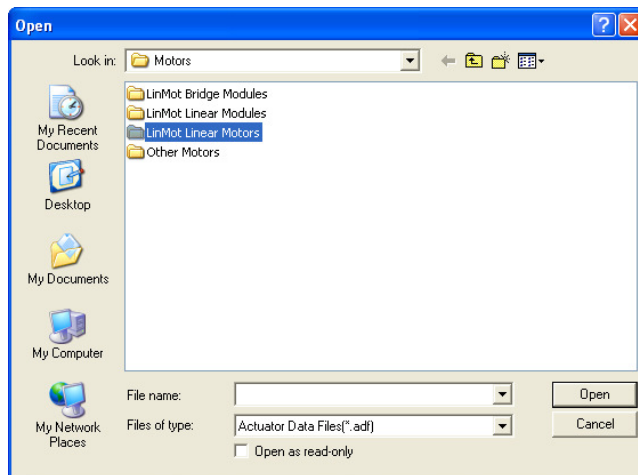

As we want to configure a LinMot Motor we choose “LinMot Linear Motors” and press Open.

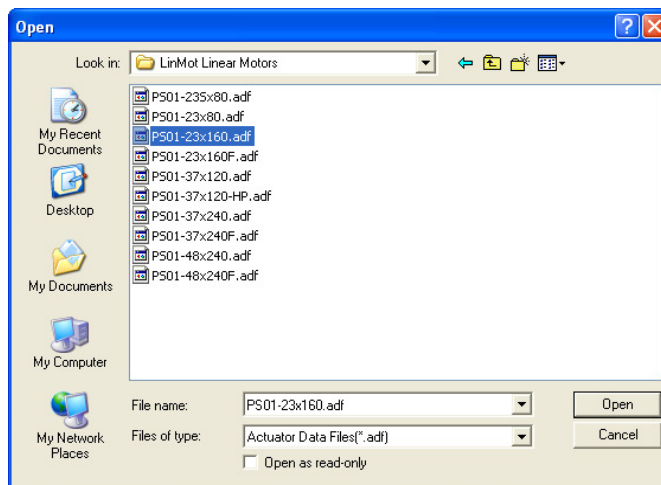

Select the actuator type you have wired to the drive, then press Open. The following steps will show forms including drawings and descriptive texts. The first step is to define the stator and slider.

Motor Wizard

Step 1/9: Actuator Selection

Actuator Data File: **PS01-37x240.adf** Change Actuator ...

Stator: **PS01-37x240**

Slider: **PL01-20x500/420**

The slider can be identified by its length. Newer sliders have the type engraved on the surface.

Slider Mounting Direction: **Regular**

The sliders are not symmetric. The value of ZP (Zero Position) depends on the mounting direction relative to the stator. Therefore the available stroke range changes with the mounting direction.

Derived Settings	Value	Comment
MOTOR	P01-37x240/160x360	
Maximal Stroke (S)	360 mm	
Shortened Stroke (SS)	160 mm	
Electromagnetic Zero Position (ZP)	130 mm	
Force Constant	40.8 N/A	
Edge Force (Fb)	58 %	
STATOR	P501-37x240	
Article Number	0150-1203	
Stator Length	347 mm	
Stator Mass	1385 g	
SLIDER	PL01-20x500/420	
Article Number	0150-1328	
Slider Length	500 mm	
Slider Mass	1064 g	

Help < Back Next > Finish Cancel

The derived settings show information about the complete motor type, article numbers and the most important technical data.

The next step is to choose the flange for defining the cooling capability.

Motor Wizard

Step 2/9: Motor Cooling

Mounting and Cooling Flange

Type: **Standard Flange**
e.g. PF0x-37x200

The bulk of power loss is deduced over the flange. The flange selection affects the firmware temperature model calculation, which is used for monitoring purposes.

Derived Settings	Value	Comment
------------------	-------	---------

Help < Back Next > Finish Cancel

Longer extension cables will have an effect to the motor's phase resistance. In step 3 can be defined two cable segments.

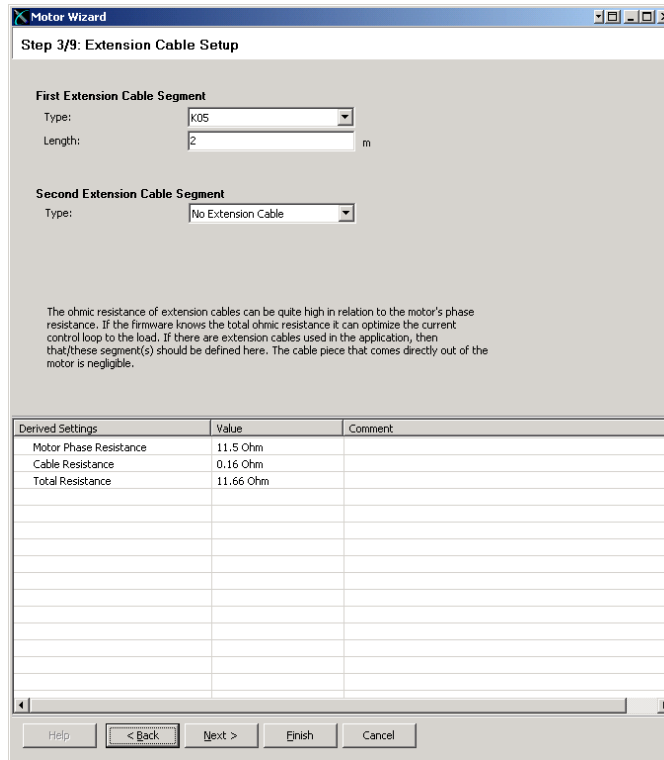

Step 3/9: Extension Cable Setup

First Extension Cable Segment
 Type:
 Length: m

Second Extension Cable Segment
 Type:

The ohmic resistance of extension cables can be quite high in relation to the motor's phase resistance. If the firmware knows the total ohmic resistance it can optimize the current control loop to the load. If there are extension cables used in the application, then that/these segment(s) should be defined here. The cable piece that comes directly out of the motor is negligible.

Derived Settings	Value	Comment
Motor Phase Resistance	11.5 Ohm	
Cable Resistance	0.16 Ohm	
Total Resistance	11.66 Ohm	

Buttons: Help, < Back, Next >, Finish, Cancel

The next hardware setup step is to define an external position sensor system (if present). For E1100 drives can be chosen between none, incremental AB(Z) and analog sine/cosine 1Vpp. For B1100 drives can be chosen between none, incremental AB(Z) and AB encoder simulation.

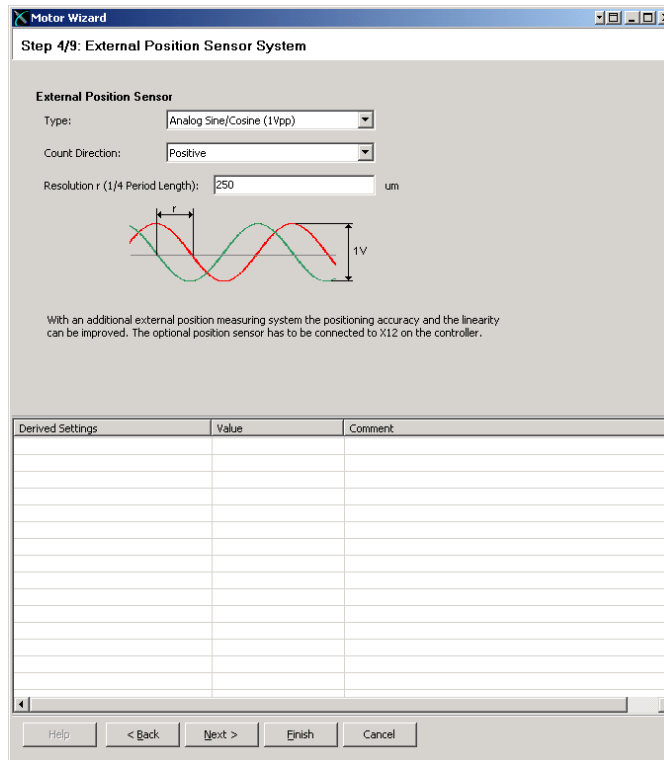

Step 4/9: External Position Sensor System

External Position Sensor
 Type:
 Count Direction:
 Resolution r (1/4 Period Length): um

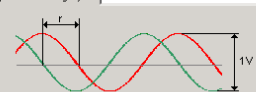

With an additional external position measuring system the positioning accuracy and the linearity can be improved. The optional position sensor has to be connected to X12 on the controller.

Derived Settings	Value	Comment

Buttons: Help, < Back, Next >, Finish, Cancel

With step 5 the feed forward parameters are set up. Depending on the moving mass, additional load mass, friction and orientation. Under the derived settings the influence can be watched.

Motor Wizard
▢ □ ×

Step 5/9: Feed Forward Parameters

Mechanical Layout
 Moving Part of Motor: ▾
 Orientation Angle (-90°..+90°): °

Moving Mass
 Slider: g
 Additional Load Mass: g

Friction Forces
 Dry Friction: N
 Viscous Friction: N/(m/s)

MagSpring (or other constant force)
 External Constant Force: N
 Force Direction: ▾

Derived Settings	Value	Comment
Total Moving Mass	1564 g	
Gravitation force in motor direction	0 N	
External Constant Force	0 N	
Sum of Constant Effective Forces	0 N	
FF Constant Force	0 A	Current for constant force compensation
FF Friction	0.049 A	Current for compensation of dry friction
FF Damping	0 A/(m/s)	Factor for compensation of viscous friction
FF Acceleration	0.038 A/(m/s ²)	Acceleration feed forward factor

Help
< Back Next > Finish Cancel

With the next and last step the position drive's parameters will be set up:

Motor Wizard
Step 6/9: PID Position Controller

PID Position Controller Setting

P Gain: A/mm (P=1, D=3, I=0)

D Gain: A/(m/s) (P=3, D=8, I=0)

I Gain: A/(mm*s)

Noise Filter

Dead Band: mm Enable Noise Filter

Beside the feed forward parameters (see previous step), the PID controller setup influences the control behavior. For the most applications it is possible to achieve good results with one of the given default settings (no additional loop tuning necessary).
The Noise Filter eliminates noise from the position feedback sensor when the motor stands still.
On Applications which require high positioning accuracy (typically together with an external position sensor) the Noise Filter should be disabled.

Derived Settings	Value	Comment
P Gain	1 A/mm	
D Gain	3 A/(m/s)	
I Gain	0 A/(mm*s)	
Integrator Limit	8 A	
Maximal Current	8 A	
Noise Filter Dead Band	0.02 mm	

Help < Back **Next >** Finish Cancel

It is recommendable to start with the default soft settings, because the parameters can be changed any time later on (by restarting the motor wizard or by setting in the parameter tree directly).

With the soft parameter setting, PID values will be quite low such as the motor is low noise and the position is not controlled very stiffly.

The stiff parameter set tends to more noise and more power consumption of the motor, but the position will be controlled harder.

In both settings, the I Gain is set to zero, which means a steady-state deviation from the desired position can occur. When using the I Gain, the position controller may tend to swing.

The Noise Filter option is to reduce the noise from the position feedback sensor at standstill.

For finding the best set of PID parameters, the system has to be optimized iteratively. There is no general way of how to optimize the settings, because different goals can be achieved such as position accuracy, power minimization, noise reduction, ...

The next step is to define the homing procedure.

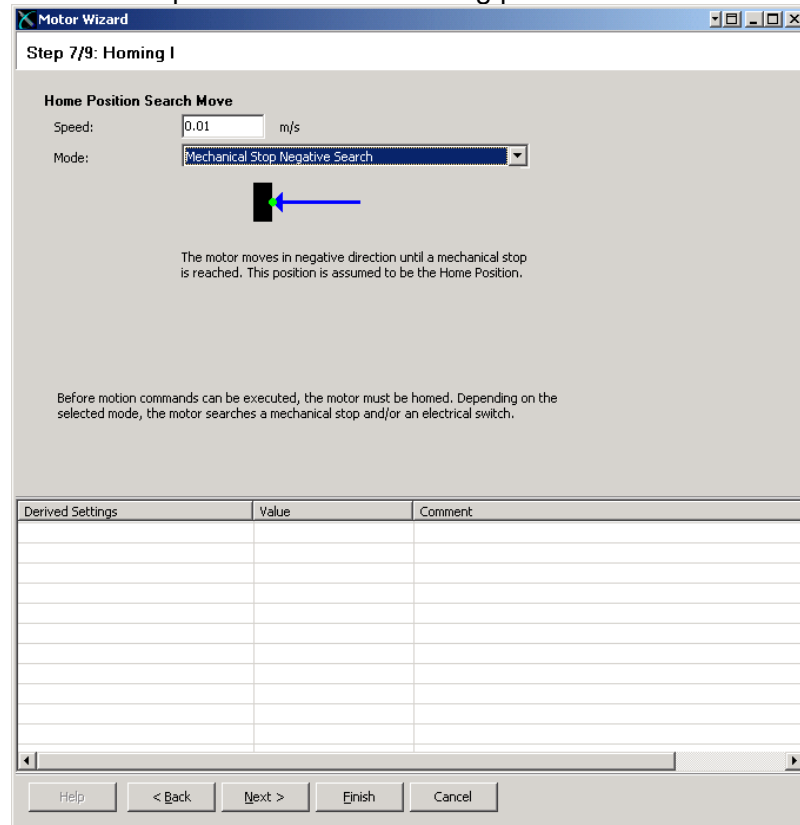

The most frequently used homing mode is “Mechanical Stop Negative Search”. In this case the slider will move with the notch towards the stator’s front end (where no cable is).

Other modes support homing on home switches, limit switches, indexer inputs or some combinations of those.

Step 8 is to define the slider home position. This is for the motor and drive the most important value. It defines at the home position, where the slider is positioned relative to the stator. This defines how far the motor can move in each direction.

Motor Wizard

Step 8/9: Homing II

Distance from Stator End to Slider End at the Home Position

Distance A: mm

Distance B: mm

The controller needs to know the physical position of the slider relative to the stator. Please determine either distance A or distance B when the motor stands at the Home Position (mechanical stop or switch). Hence you can move the motor manually to the Home Position. Then you can measure A or B (stator end to slider end) and enter the corresponding value. The other value is calculated by the software. If the slider end is inside the stator tube, then you have to give your entry a negative sign.

Derived Settings	Value	Comment
Slider Home Position	10 mm	Corresponds to distance A

Help < Back Next > Finish Cancel

With the last wizard step the user's coordinate system can be defined.

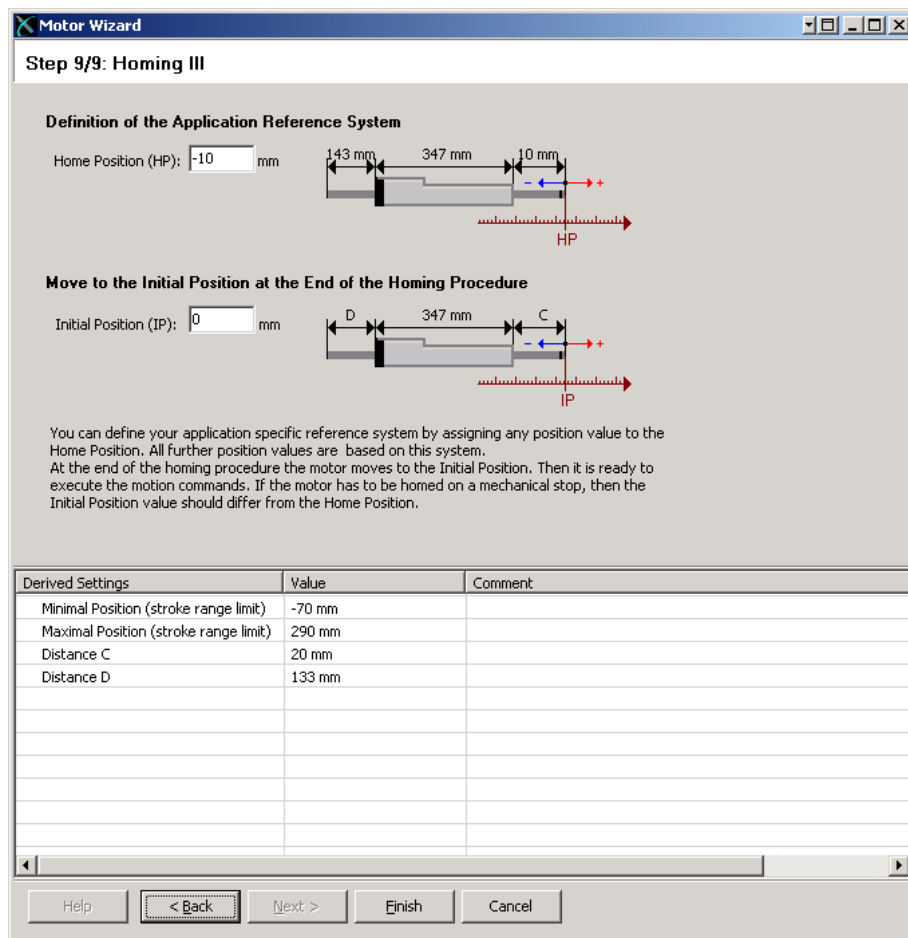

At the end, press finish. If the firmware on the drive is still running, an appropriate message will be shown. All parameters will now be written to the drive.

The motor wizard can be run several times, e.g. to setup an external sensor, to change the load setup or to change the motor type. When rerunning it, at the end will be shown a list of parameters, which will be changed.

3.11 Continuous Curve Mode

We want the motor to run a curve cyclically. (The easiest, but not so informative way to run the motor would be the VAI 2 Pos Continuous mode) The drive is set to continuous curve mode by selecting “Continuous Curve” under \Motion Control SW\Motion Interface\Run Mode Settings\RunMode Selection\ in the parameter tree.

NOTE: For enabling the curve feature on B1100 drives, it is necessary to set an access key.

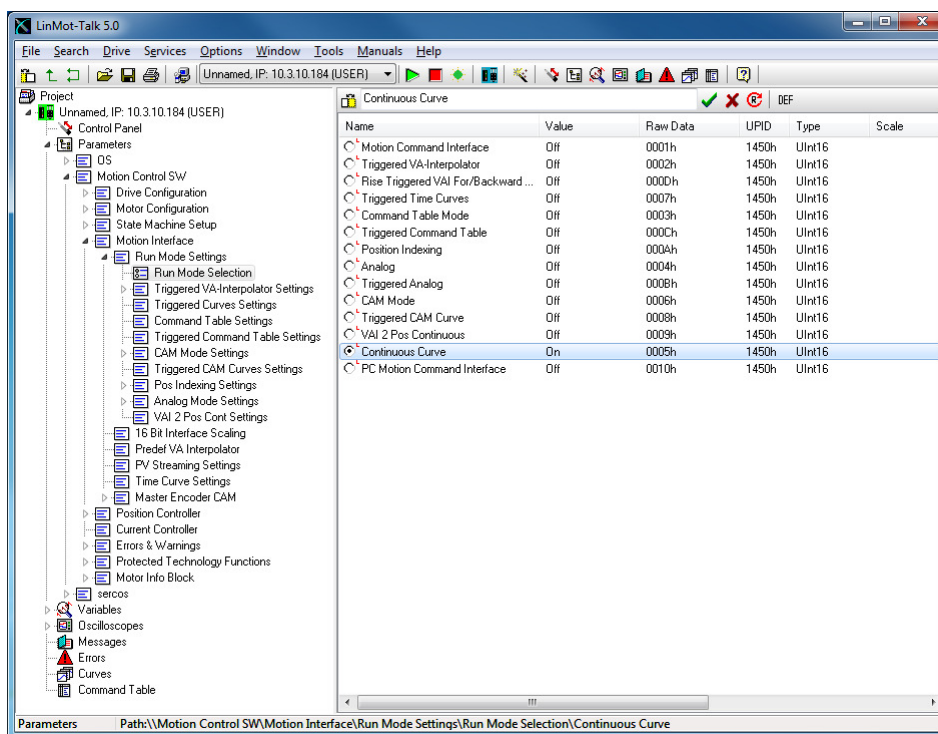

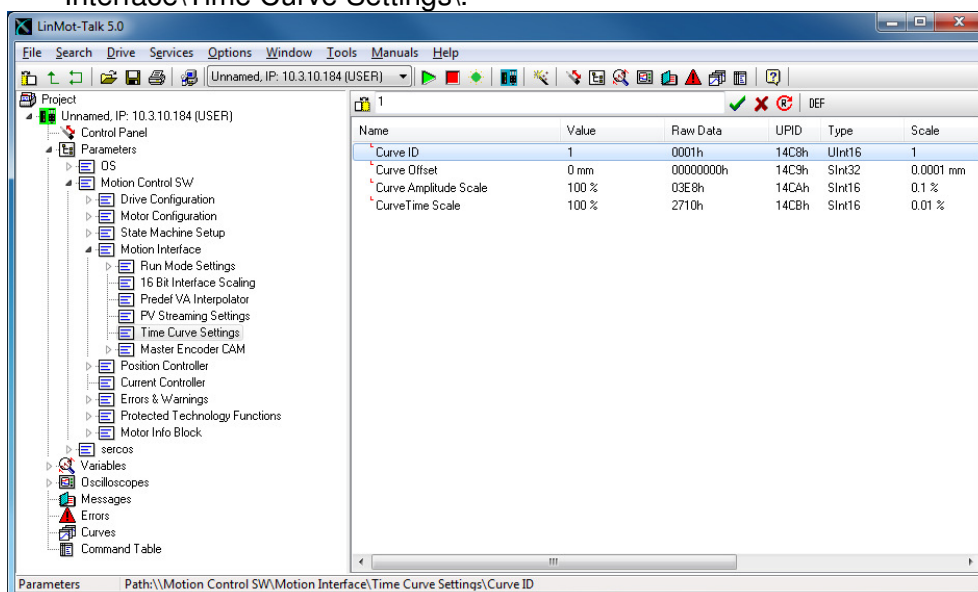

The second parameter to be set is to define which curve has to be run. Set the parameter “Curve ID” to 1 under \Motion Control SW\Motion Interface\Time Curve Settings\.



Before running the curve, it is advisable to define the curve we want to run.

3.12 Defining Curves

Curves can be easily defined with the curve wizard. For this example we will define two sine curve forms over a stroke of 50mm out and in with different speeds, which will be joined together.

Now, step by step: Open the curve tool by clicking the “Show Curves” button  in the tool button bar. Then press the “New Curve” button  to start the curve wizard.

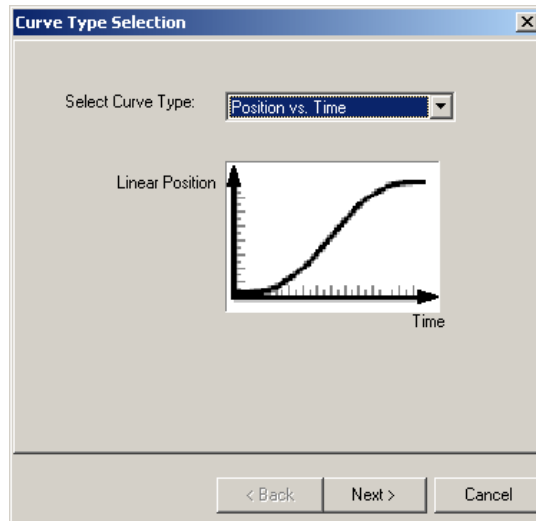

As we want to define a curve in position vs. time mode we can keep the default selection and press the next button.

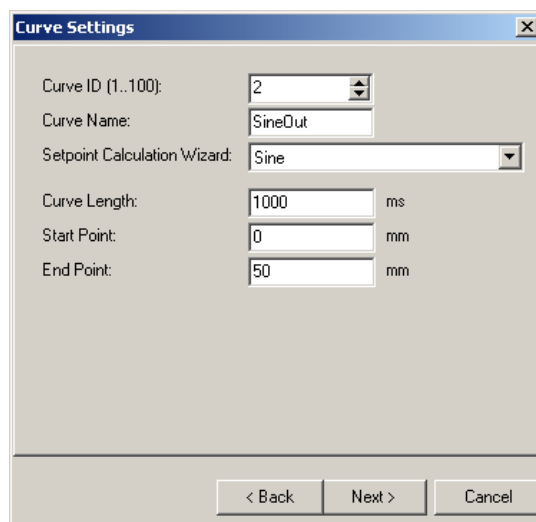

In this mask, we will set the curve ID to 2 (we will have the merged curve with ID 1 at the end) and as name we set e.g. “SineOut”. The end point is placed at 50mm. With “Next” the wizard will show some curve data:

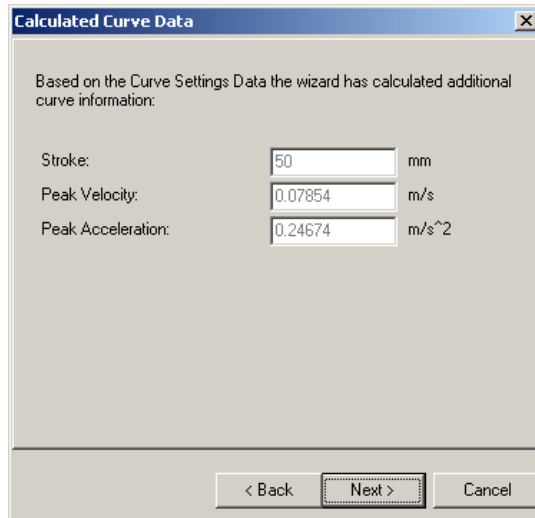

The next and last mask proposes a number curve setpoints. It is advisable to accept this proposal.

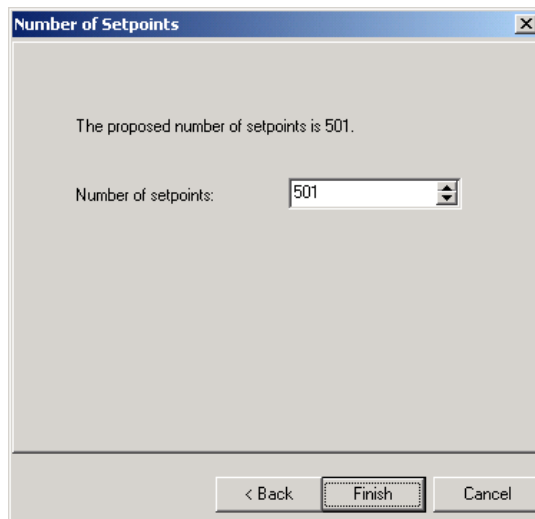

With “Finish” the first curve is defined. The curve will be displayed as follows:

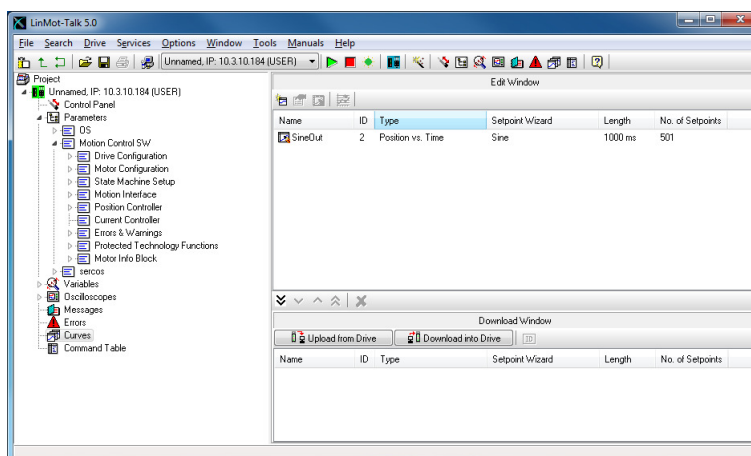

We will now define curve going back. So we start the curve wizard again and define under curve settings the following:

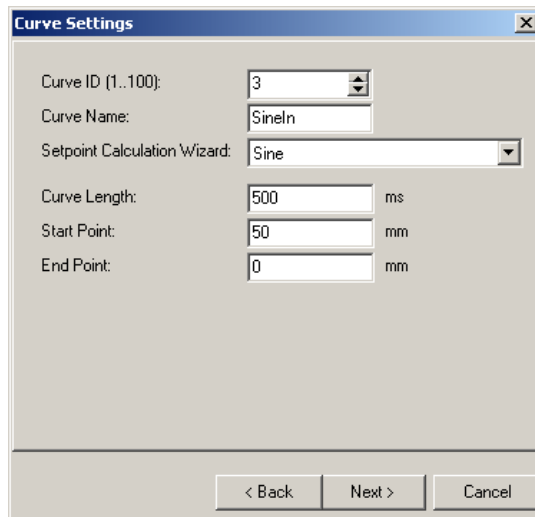

Set curve ID to 3, Curve Name to “SineIn”, Curve Length to 500ms, Start Point to 50mm and End Point to 0mm. Click twice “Next” and then “Finish”. Now we have defined the two curve segments and will join them together. Select the two curves

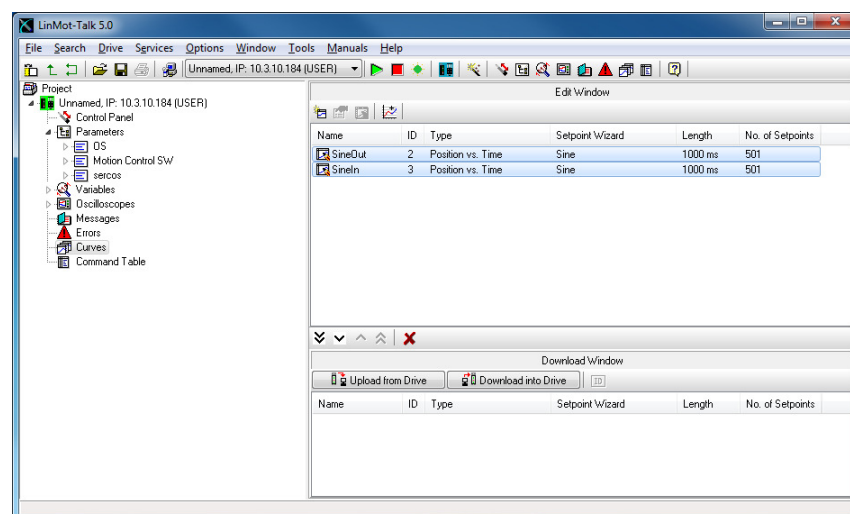

then press the “Join Curves” button  . The curve settings mask for the joined curve appears:

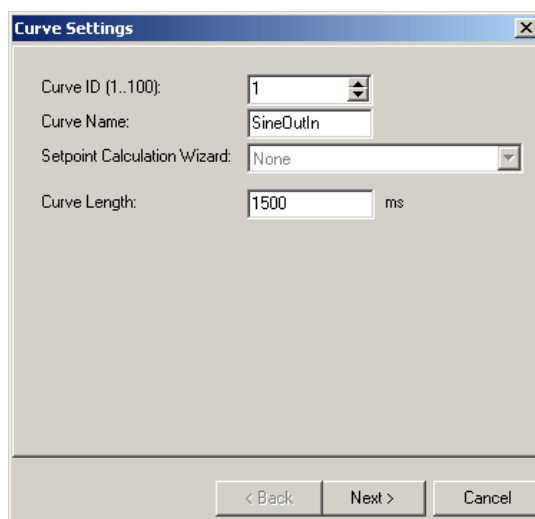

We will set the curve name to “SineOutIn” and make sure the curve ID is 1. The curve length is proposed as the sum of the curve segment times. Press “Next” and “Finish”. The curve for the continuous curve mode is now defined and has, according to the parameter settings, the curve ID 1. As we want to download the curves to the drive we select all the curves in the edit window and move them to the download window.

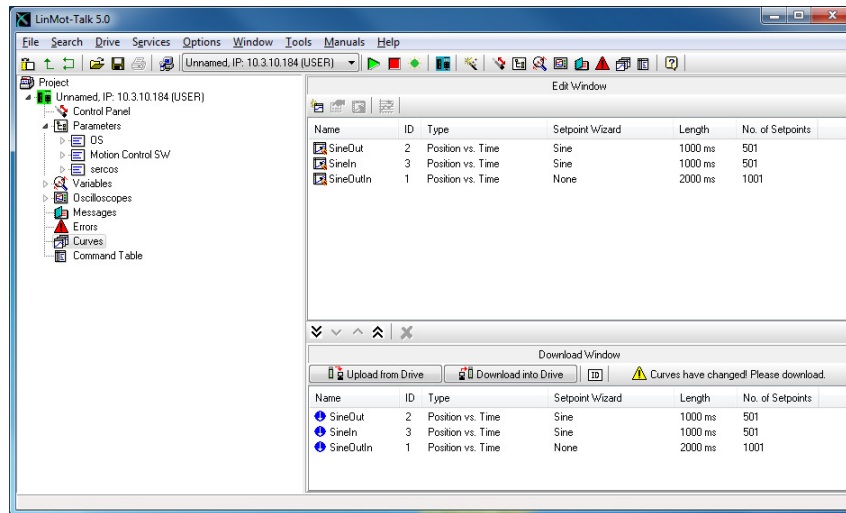

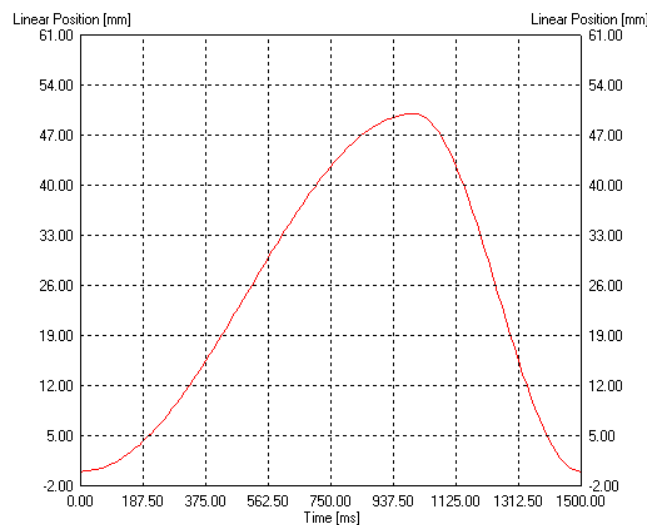

When double click the “SineOutIn” Curve the joined curve is shown:

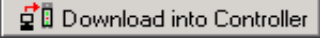

Now the curves must be downloaded to the drive. Therefore press the “Show Curves” button  and then the “Download Curves into Drive” button . Then a warning comes up which has to be confirmed and the progress window will display the actions taken to download the curves.

3.13 Control Status

As we have defined now all parameters and curves, we will let the motor running. For this time, we will take over the interface control from the PC. So we are interface-independent.

Switch to the control panel with the button , then press the start button  (starting the drive's firmware) and wait until the control status panel is updated and looks the following:

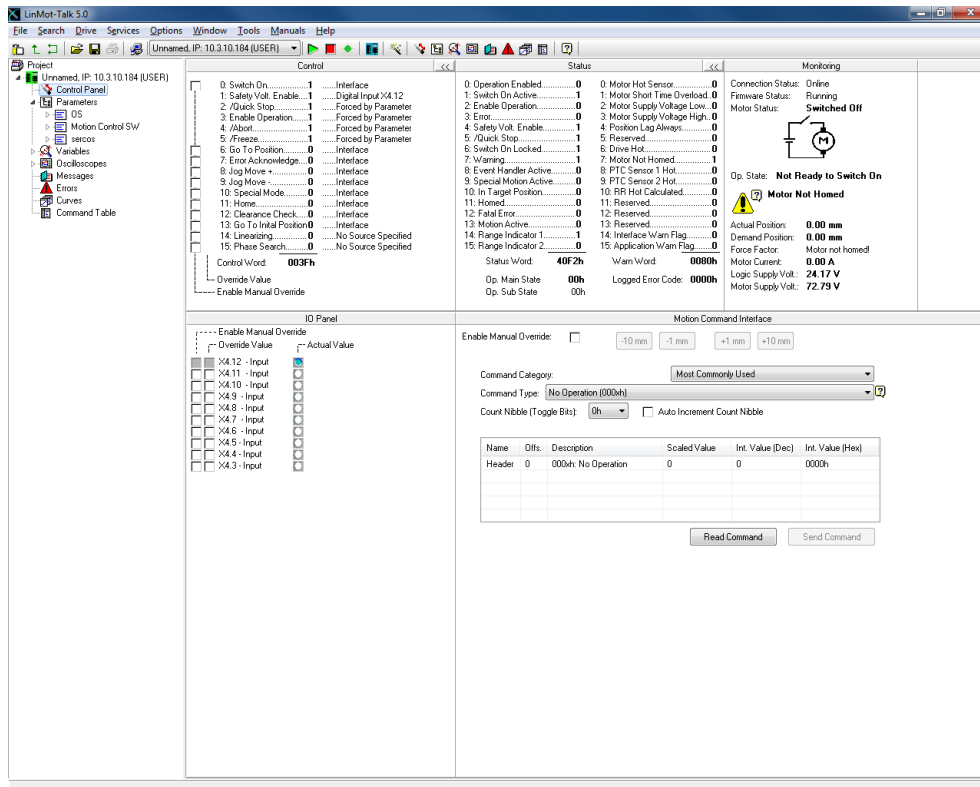

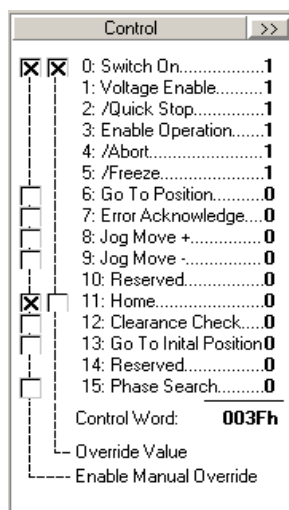

Now we will fetch the control over the “Switch On” and the “Home” flags.





Now turn off and turn on again the “Switch On” flag, this is because of the auto start prevention. At this time, the motor will be powered and position controlled at the actual position. Set the “Home” flag and the motor will initialize against the inner hard stop. When the motor stands still, clear the “Home” flag and the motor will run the curve continuously.

Detailed information about the MC software's state diagram can be found in the MC software manual.

3.14 Oscilloscope

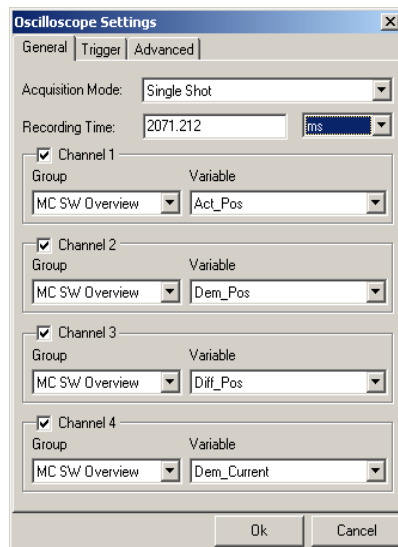
The oscilloscope is a very useful tool for tuning the motor. The LinMot-Talk software has defined a default oscilloscope, which samples the actual position, demand position, position difference and demand current. When clicking on the “Show Oscilloscope” button , the focus will be set to the default oscilloscope. We could start the oscilloscope now with the start button , but it is recommended to set the recording time about 2 seconds (one curve cycle is 1.5 s). We will switch to the oscilloscope settings with .



Then press Ok and start the oscilloscope with . The recorded data on will be read out from the drive and displayed, which will look somehow like the following.

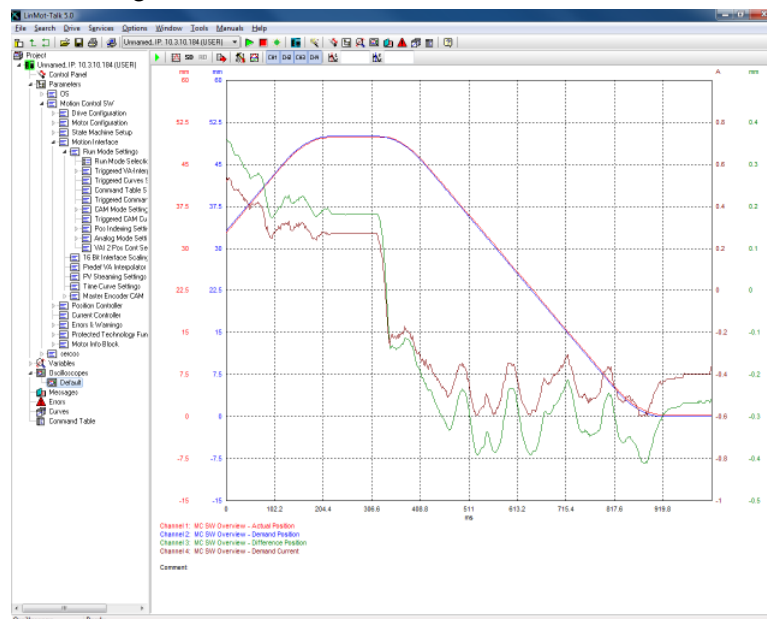

Possibly it is necessary to press button  (fit view).

Tuning the system would be started at this point. One possibility is by restarting the Motor Wizard and changing the load or control parameter, another one is to change the parameters directly in the parameter tree.

3.15 Continuous Two Point Mode

The easiest way to run the motor continuously is to set the VAI 2 Pos Continuous mode. In this mode the motor moves between the two positions Trig Fall and Trig Rise. The time the motor waits at the two positions is defined under “VAI 2 Pos Cont Settings”.

The minimal settings for this mode are shown next. First the mode has to be set:

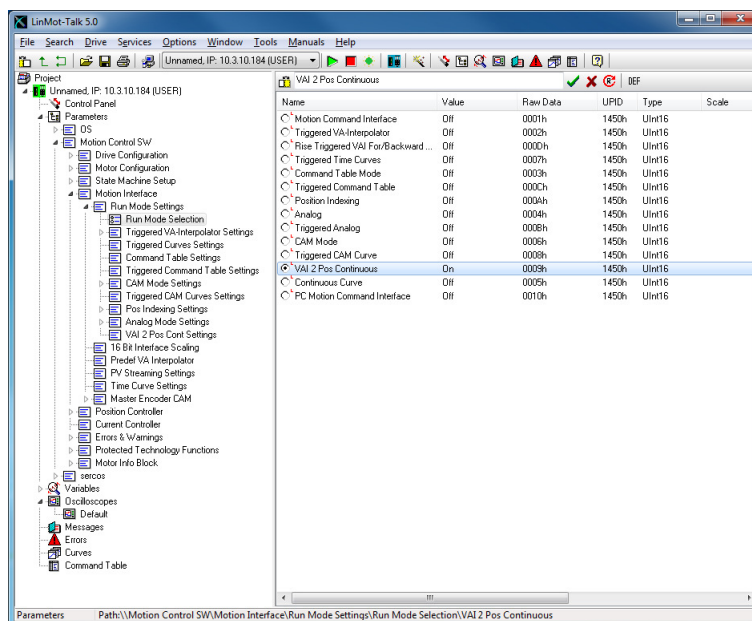

And then the positions have to be set under “Trig Fall Config\Position” and “Trig Rise Config\Position”:

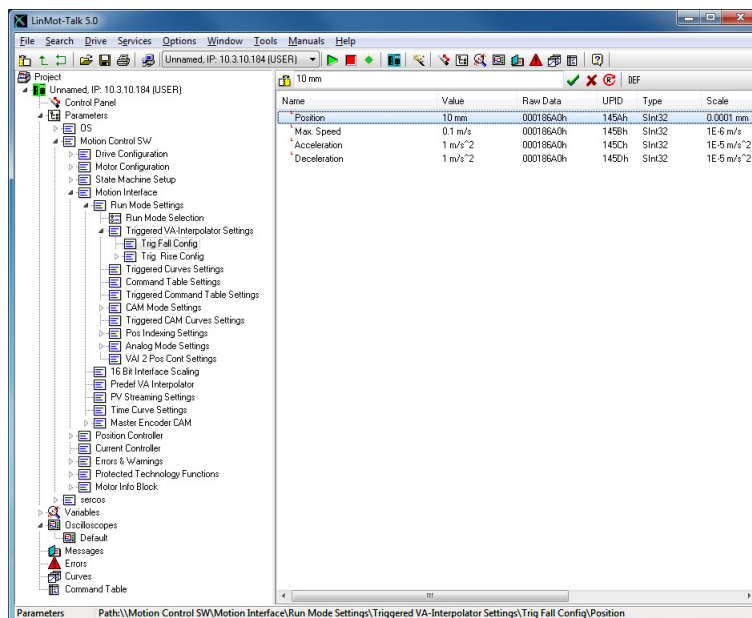

This is all we have to configure. The speed, acceleration and deceleration can also be defined at this place in the parameter tree. The motor can now be started the same way as described under 3.13 Control Status.

3.16 Export Configuration

When the drive settings are done it is strongly recommended to save the complete configuration. This can be done under File → Export... or with by clicking on . After the file name dialog the selection of the parts to be exported will be shown:

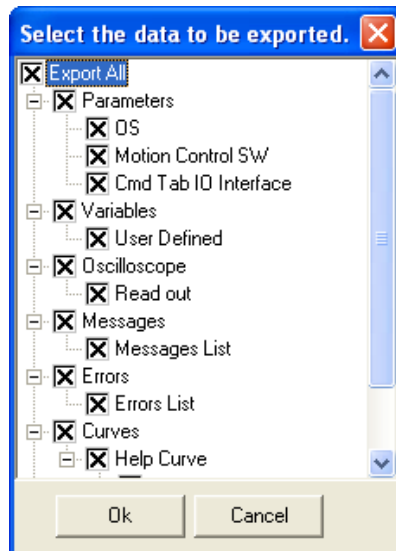

It is recommended to export all. For a configuration recovery it is necessary to select the parameters, curves and command table.

In case of a support request it is very helpful to provide the complete configuration as well (with variables, oscilloscope shots, message and error log).

3.17 Import Configuration

A configuration can be imported with File → Import... or with the button . When opening a configuration to a drive, a compatibility list of the parameter trees will be shown. Then the selection of the importable parts will be shown:

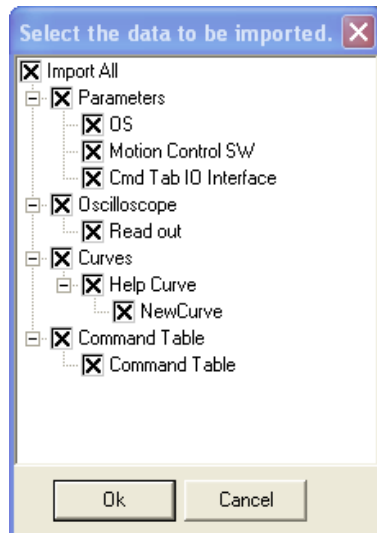

It is possible to import only some specific parts (e.g. curves or command table).

3.18 Open Offline Configuration

A configuration can also be opened when no drive is present. Under File → Login/Open offline...

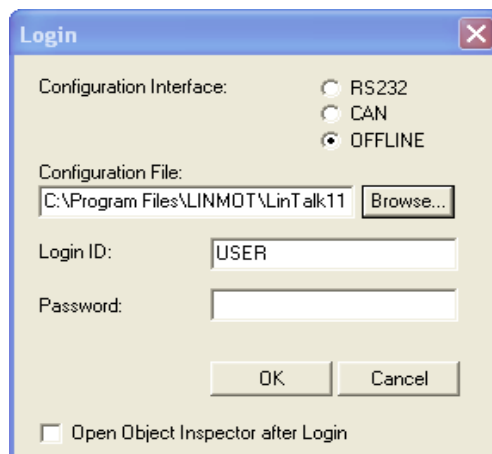

This is a very helpful feature for supporting problems.

3.19 Create Offline Configuration

For any supported drive a configuration can be created offline. Choose the menu item File\Create Offline...

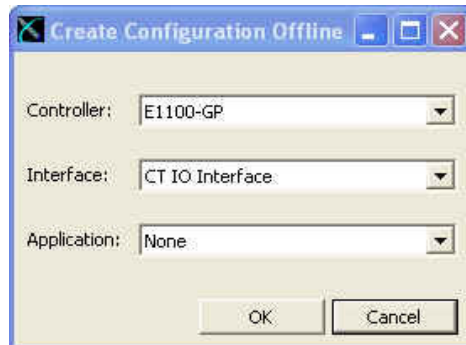

The above window will be shown. Select the drive first, then choose the interface and application software. The software parts, which can be selected, are the same as when installing firmware to the drive. When created the configuration, the parameters will have their default values. The configuration can then be altered and saved the normal way.

4 Trouble shooting

4.1 Setting all Parameters to Default Values

E1100, E1200, E1400 and B8050

All parameters of the SG3 and SG5 drives can be set to their default values without the use of the LinMot-Talk. This can be done according these steps:

1. Power off the drive
2. Set the two ID switches to 0xFF
3. Power on the drive, the ERROR and WARN LEDs will blink alternately.
4. Set the two ID switches to 0x00
5. Wait until the WARN and EN LEDs will flash together.
6. Power off and on again.

B1100

On SG4 drives an image of the default parameters will be stored during the software installation. This image can be reloaded to the operating parameters. The procedure is the following:

1. Set the parameter with UPID 0x6085 to 0x0001.
2. Power off the drive.
3. Power on the drive.

The value of the parameter with UPID 0x6085 will be automatically cleared to 0x0000.

4.2 Interface does not run

If the interface software (DeviceNet, CANopen, Profibus, LinRS) does not communicate there may be several reasons:

- Specific Interface Software not installed
- Switch S3.4 "Interface" on drive's bottom side must be set to "On". (In case of LinRS, this switch must be set to off when configuring over RS232, and set to on when running the LinRS interface).
- Parameter with UPID 2008h set to disable.
- Baud Rate and Node ID selection not correctly set (Parameters and/or ID switches on drive's front).

4.3 Stopping Firmware

When the same link is used for configuration purposes and from the interface (e.g. RS232 link and LinRS interface) it may not be possible to login with the LinMot-Talk software. In some cases, it should be possible to log in, e.g. to download new firmware.

On E1100 drives, the interface switch S3.4 can be set to off and after a power up the interface software should be deactivated and the configuration link should be free. If this does not help, or you are working with a B1100 drive, there is a script under File -> Open -> StopFirmware.sct, which keeps trying to stop the drives firmware while it is powered on. After a power up, within the first 2 seconds the interface can be prevented from starting.

5 Contact Addresses

SWITZERLAND

NTI AG
Haerdlistr. 15
CH-8957 Spreitenbach

Sales and Administration: +41-(0)56-419 91 91
office@linmot.com

Tech. Support: +41-(0)56-544 71 00
support@linmot.com

Tech. Support (Skype) : skype:support.linmot

Fax: +41-(0)56-419 91 92

Web: <http://www.linmot.com/>

USA

LinMot, Inc.
5750 Townline Road
Elkhorn, WI 53121

Sales and Administration: 877-546-3270
262-743-2555

Tech. Support: 877-804-0718
262-743-1284

Fax: 800-463-8708
262-723-6688

E-Mail: us-sales@linmot.com

Web: <http://www.linmot-usa.com/>

Please visit <http://www.linmot.com/> to find the distribution near you.