

(c) 1998 Sulzer Electronics AG/LinMot®

This work is copyright.

All rights to it are reserved, including translation, copying and duplication of the handbook or parts of it. No part of the handbook may be duplicated or distributed in any form (photocopied, microfilmed or any other process) including for purposes of instruction, reproduced or processed by means of electronic systems, without the written permission of Sulzer Electronics AG.

LinMot® is a registered trade mark of Sulzer Electronics AG.

**Note:**

The information given in this documentation embodies the state of development at the time of going to print and is therefore not binding.

Sulzer Electronics AG reserves the right to effect amendments serving technical progress or product improvement at any time and without stating reasons. Otherwise we refer to our "General Business Conditions" in the particular valid edition.

<b>Introduction .....</b>	<b>4</b>
LinMot® as design element.....	4
Technologies compared.....	5
Software versus mechanisms .....	5
Innovation potential.....	6
<b>Safety precautions .....</b>	<b>7</b>
<b>Typical Applications .....</b>	<b>8</b>
Placing and assembling in XZ and XY directions.....	8
Filling bottles by XZ motion.....	8
Testing systems .....	9
Stacking and accelerating.....	9
Stacking parts .....	10
Counting and separating.....	10
Picking up parts with a scoop.....	11
Aligning and diverting boxes .....	11
Pneumatic grippers .....	12
Linear and rotary motion .....	12
Assembly line combined with quality assurance .....	13
Pushing-in parts .....	14
Gluing-on labels .....	14
Printing inscriptions.....	15
Testing switches.....	15
Applying coatings.....	16
Coiling wires and winding threads.....	16
Horizontal movement with preload.....	17
Applying a constant tension .....	17
Welding-on with constant distance to work.....	18
Inserting parts in injection moulds/tool changing .....	18
Braking (damping) parts.....	19
Vibration testing .....	19
Auxiliary drive for servosystems.....	20
Controlled immersion of parts in liquids .....	20
When dipping parts in a liquid it is often necessary to perform the immersion and withdrawal under tight control. These in and out movements are often carried out at very different speeds, or else splashing must be avoided. Here too, motion profiles enable optimal adaptation to the situation (e.g. fast approach, slow immersion till the surface tension of the liquid is overcome, rapid complete immersion). .....	20
Moving stator.....	21
Two moving stators on one slider .....	21
Paralleled motors .....	22
<b>Pictures of applications .....</b>	<b>23</b>
Parallel kinetics .....	23
Two stators on one slider .....	23
.....	23
.....	24
Packaging machine for biscuits.....	24
Introducing single biscuits.....	26
Damp and dirty working environments.....	27
Synchronizing belt conveyor levels.....	27
<b>Designing.....</b>	<b>28</b>
Slider couplings.....	28
Rigid coupling by screw connection.....	28

Rigid coupling by clamping .....	28
Flexible couplings .....	29
Twisting and fall-out safeguard .....	31
Ways of fixing the motors.....	32
Supplementary guides .....	34
Linear guiding (recirculating ball units) .....	34
Shaft guides.....	36
Coupling to lever mechanisms.....	38
Statische Kräfte.....	39
Moving stator/stationary slider .....	40
Stator on roller guides.....	40
Cable led in trailing chain to moving stator .....	40
Motor cooling .....	41
Forced air cooling .....	41
Applications.....	42
Compact XY unit.....	42
Vacuum.....	43
Pick und place with vacuum.....	44
Feeler head assembly for measuring force.....	45
Stacking and sorting .....	46
Gripping moving parts at different places .....	47

## Accessories ..... 48

Coupling elements .....	48
Ball-and-socket heads .....	48
Clevises .....	48
Ball-and-socket joints.....	48
SMC compensators .....	49
Flexo coupling from FESTO.....	49
Linear recirculating ball guides .....	50
SHS recirculating ball guides from THK.....	50
INA roller guides .....	51
INA miniature recirculating ball units KUME .....	51
INA plain bearing bushes and shafts .....	51
Linear guides with plain bearings.....	52
FESTO guide units FEN-8/10-... for motors P01-23x.....	52
FESTO guide units FEN-20-... for motors P01-37x.....	52
IGUS DryLin T - with clamping .....	53
IGUS DryLin N - miniature profile .....	53
Plain bearings.....	53
Trailing chains.....	54
Trailing chain cable.....	54
Lubricants .....	55
Bellows.....	55
Load compensation for vertical movements .....	56
Compression springs .....	56
Tension springs.....	56
Gas springs.....	56
Clamping elements .....	57
Pneumatically opening circular guide clamping (MKR).....	57
Electromechanical clamping .....	57
Stepper motors .....	58
Electrical grippers .....	58
Grip PE 410 .....	58

## Mechanical dimensions of LinMot® products ..... 59

Analog and Multitrigger electronics units .....	59
PROFIBUS-DP electronics units.....	59
Linear motors family P01-23x80 .....	60
Linear motors family P01-23x160 .....	61
Linear motors family P01-37x120 .....	62
Linear motors family P01-37x240 .....	63
PF01 flange.....	64

## Conversion tables and units ..... 65

## Notes: ..... 67

# Introduction

25 years ago microprocessorrevolutionized the control and attendance of machines. Now linear motors are redefining their designing.

## **LinMot® as design element**

The first linear motor was invented at the middle of the last century, practically the same time as its brother - the rotary electric motor. Owing to the fact that a linear motor must always perform a reversing motion (from one end of the motor to the other and back again), as an energy source it is physically handicapped compared with the rotary motor. But where linear, short-stroke positioning movements are needed (as is very often the case on textile and pakkaging machinery, in handling or specialized mechanical engineering), the linear motor becomes the ideal design element. Mechanical components subject to wear or claiming space, like gears, levers or belts, are entirely absent. The linear motion is generated straight from the electromagnetic force.

The real innovation in the LinMot® P linear motor family lies in the consistent application of the basic idea for a modern design element. From the illustration below it will be clear that everything, from the actual motor parts through the bearings to the position detection and sensing electronics, has been integrated in a rugged metal cylinder. The entire assembly is based on formed parts and mouldings; the only two screws serve to fix the EMC cable. Only this, for linear motors novel design, will stand up to the severe industrial requirements imposed upon a design element in mechanical engineering.

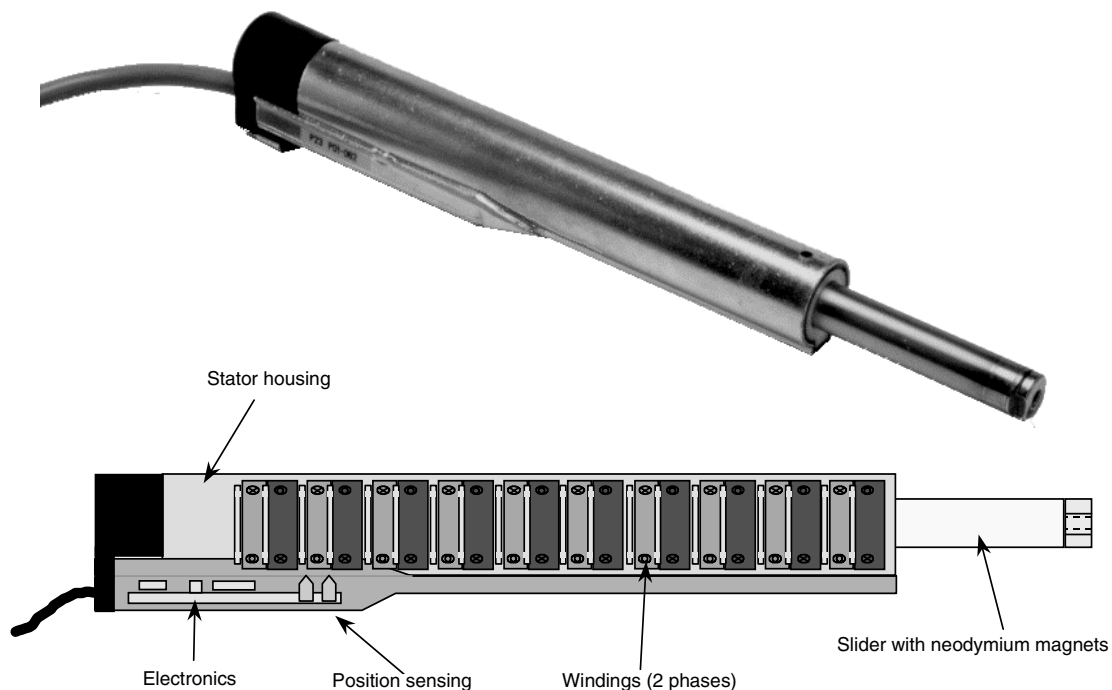

**Assembly of a permanent-magnet synchronous linear motor of the LinMot® family.**

## Technologies compared

The outstanding technical capabilities of LinMot® linear motors may be summed up as follows:

- freely positionable
- electronic cam function
- extreme accelerations
- cyclic motion frequencies
- suitable for severe industrial environments
- long life

By comparison, pneumatic devices are neither freely positionable nor are their dynamics comparable. Linear motions derived from a rotary movement of a servomotor (belt, spindle) are inferior on the counts of size, dynamics and service life, owing to their many mechanical parts. Compared with purely mechanical systems like levers and cams, the electronic programmability of LinMot® P emerges as a particular advantage.

## Software versus mechanisms

There isn't a designer who doesn't find the time between his idea and fitting the finished mechanical part too long. And no user enjoys having to change components on his machine just because production has to be switched. Industrial linear motors now make possible not only free scaling of the motion speed but the setting of other positions, motion profiles or functions by pressing buttons. The illustration below shows how motion profiles and motion sequences are determined by means of software and then performed immediately. The process-oriented programming assisted by LinMot® thus promotes the basic idea of decentral function units.

State	Drive A - LinMot	Drive B - LinMot	Drive C - Stepper	Drive D - Magnet
0	<b>Abs. Position</b> Position 36.992 mm Max Speed 2 m/s Acc. 10.014 m/s <sup>2</sup>	<b>Abs. Position</b> Position 18.008 mm Max Speed 2 m/s Acc. 10.014 m/s <sup>2</sup>	<b>Abs. Position</b> Position 2 Step Max Speed 50.011 Step/s Acc. 95.374 Step/s <sup>2</sup>	<b>No Operation</b>
1	<b>Rel. Position</b> Increase 5 mm Max Speed 2 m/s Acc. 1.9074 m/s <sup>2</sup>	<b>No Operation</b>	<b>No Operation</b>	<b>No Operation</b>
2	<b>No Operation</b>	<b>Rel. Position</b> Increase 5 mm Max Speed 2 m/s Acc. 1.9074 m/s <sup>2</sup>		
3	<b>No Operation</b>	<b>No Operation</b>		
4	<b>No Operation</b>	<b>No Operation</b>		
5	<b>Curve</b> Curve number 2 Max Speed 2 m/s Acc. 10.014 m/s <sup>2</sup>	<b>Curve</b> Curve number 2 Max Speed 2 m/s Acc. 1.9074 m/s <sup>2</sup>		
6	<b>Stop</b> Max Speed 0.00038147 m/s Acc. 10.014 m/s <sup>2</sup>	<b>Stop</b> Max Speed 0.00038147 m/s Acc. 10.014 m/s <sup>2</sup>		
7	<b>No Operation</b>	<b>No Operation</b>		

**LinMot Edit Curve**

Wizard Type:

Drive Type:

Name:

Time:  [ms]

Start Point [mm]:

End Point [mm]:

max Speed [m/s]:

max Start Acc [m/s<sup>2</sup>]:

max Stop Acc [m/s<sup>2</sup>]:

Position [mm] vs Time [ms] graph showing a smooth curve starting at 0.00 ms and 0.00 mm, rising to approximately 19.00 mm at 23.09 ms.

Buttons:

Buttons:

Parameters and motion profiles can be generated simply with graphic aids.

## Innovation potential

The design of a machine is determined by two guidelines, first the actual function to be performed, second the technical possibilities open to the designer. Accordingly the previous necessity of accomplishing rapid linear motions by means of centrally driven cams and levers dictated the designs of many machines. Here LinMot® makes possible a genuine breakthrough by enabling the designer to concentrate solely on the purposeful performance of the function needed. If he needs a linear motion, he takes the LinMot® P design element and achieves this movement in situ. Decentral function units result. Synchronization, switch-on behaviour and emergency situations are defined via software. In this way the decentral function units themselves become modules which are coupled together. The machine becomes modularized, or in other words it is put together from function modules and not designed anew each time.

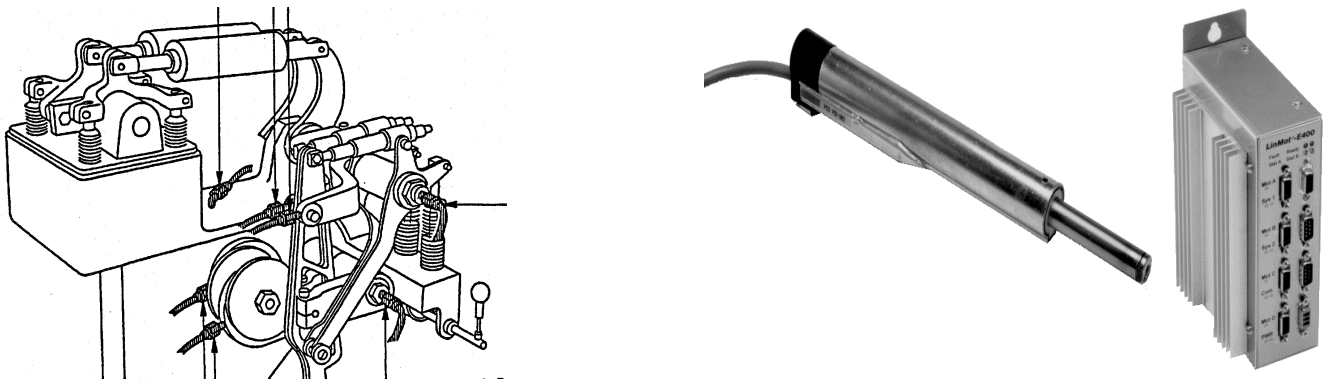

**Industrial linear motors make possible the assembly of decentral function units.  
Mechanisms are supplemented by software.**

Contemporary machine designs as used in textile production, packaging and handling are too complex and mature for a new design element to change their world overnight. But with the LinMot® P industrial linear motors the engineer now has a design element available that fits perfectly into a development which began with the advent of electronics in mechanical engineering, with effects and consequences familiar to everyone.

# Safety precautions

LinMot® linear motors are intended for fitting in electrical equipment or machines. During operation they have moving parts and hot surfaces, which constitute a danger of serious injury or material damage.

Linear motors must not be put into operation as intended unless the machine satisfies the relevant safety regulations.

The persons responsible for the equipment or machinery must ensure that only qualified people familiar with working on electrical equipment are employed with the equipment, in order to prevent damage and injury.

Qualified people are persons who, by virtue of their training, experience and instruction and their familiarity with the relevant standards, regulations, accident prevention rules and operating conditions, have been authorized by the persons responsible for the safety of the plant to perform the necessary activities and are able to recognize and avoid possible dangers.

The operating instructions and other product documentation must be followed consistently in all relevant work. In particular it must be borne in mind that the sliders of linear motors may be moved with extremely high accelerations, possibly giving rise to dangerous situations.

Only tested and potential-isolated power supplies may be used to provide voltage for LinMot® electronics units and accessories.

The electrical installation must comply with the regulations in force. Data in the documentation going beyond these must also be taken into account.

The linear drives must be protected from excessive stressing.  
In particular make sure when packing and transporting them that no parts are excessively loaded or even bent.

Electronic devices are inherently not proof against failure. It is therefore the user's responsibility to ensure that the linear motor is brought into a safe state if some device should fail.

In the sliders of the linear motors are powerful permanent magnets, which may damage magnetic data carriers (diskettes, credit cards etc.).

These remarks on safety do not claim to be comprehensive. Any questions and problems should be addressed to LinMot®.

# Typical Applications

The following examples show schematically some classical applications for LinMot linear motors. Details are deliberately avoided. Questions concerning designing are dealt with in a subsequent section.

## Placing and assembling in XZ and XY directions

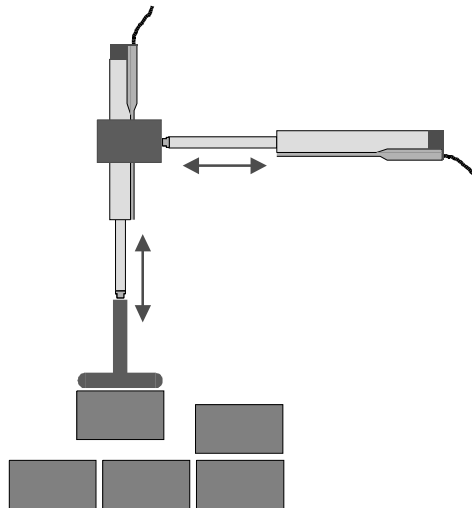

Two-axis rigs in XY or XZ direction are classical applications in handling and assembling. Usually additional guides are provided, to ensure longer strokes under high lateral loads and long life at the same time. Especially with motions in the Z direction, the gripper should be as light as possible so that its linear motor is not loaded unnecessarily by a continuous force. If necessary springs, counterweights or relief cylinders may be used to compensate the mass of the gripper head in the vertical direction.

## Filling bottles by XZ motion

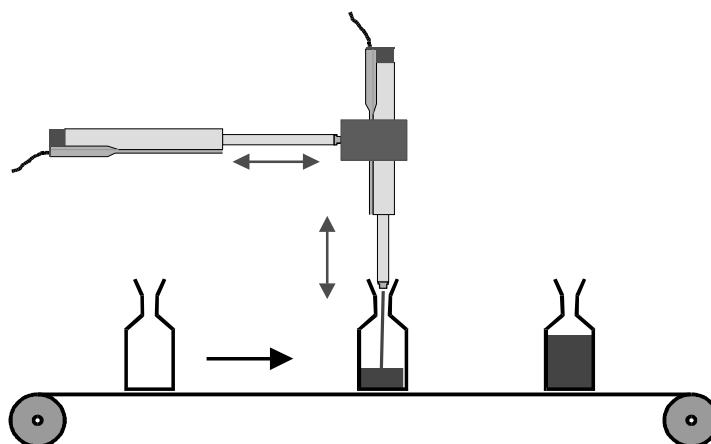

The high dynamics of the linear motors enable bottles to be filled on the moving belt conveyor. For this the filling pipe is mounted parallel to the slider of the vertical linear motor, similar to a pneumatic gripper (see design drawings for pneumatic grippers). If necessary the solenoid valve for the liquid may also be controlled by LinMot electronics.



## Testing systems

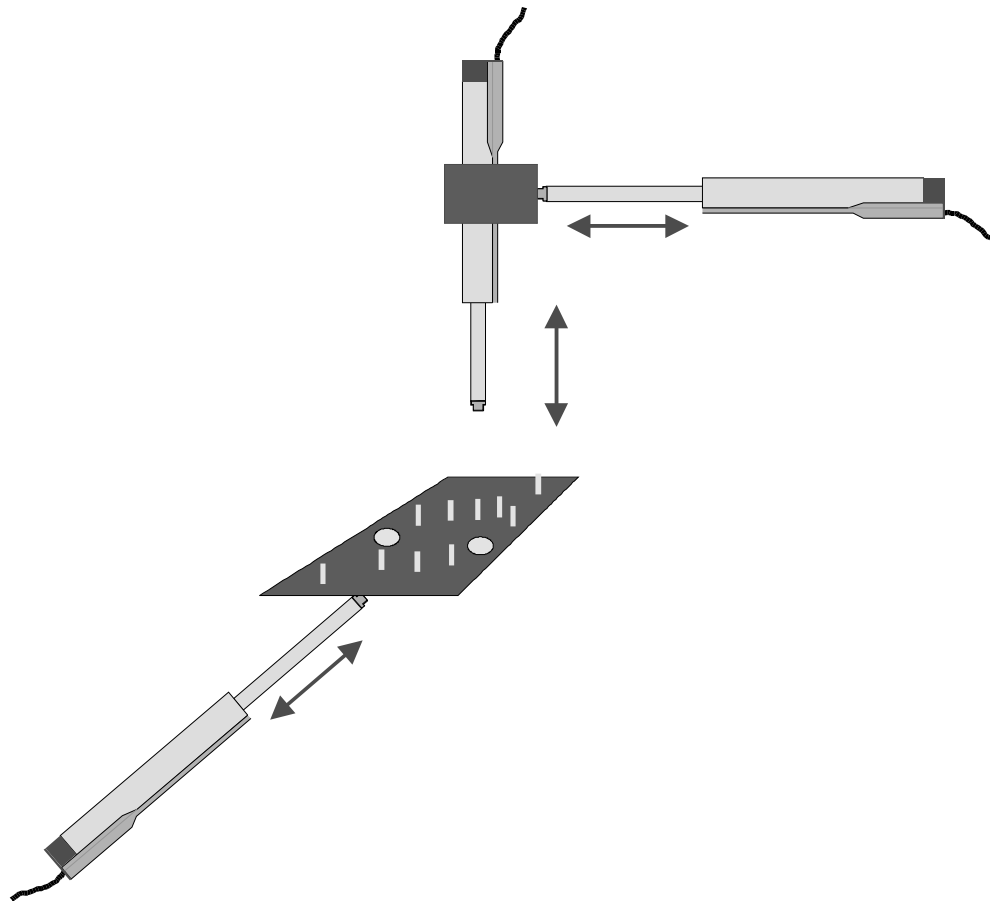

The vertical linear motor moves a stylus against the part to be tested. On account of the material flow the motor with the stylus is moved in one direction, while the container with the parts to be tested is moved in another direction. Either special measuring sensors are integrated in the stylus, or else the force controllability of the LinMot motors and the position feedback signal are used for detection.

## Stacking and accelerating

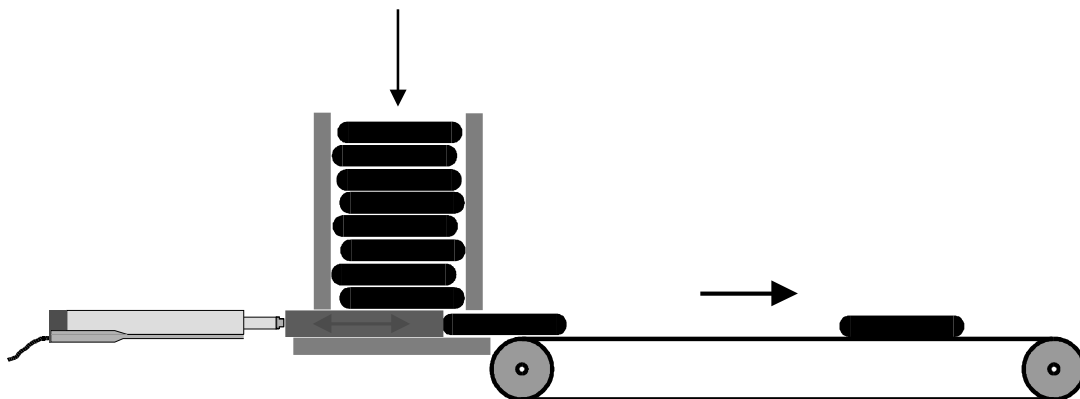

Stacked parts or biscuits are to be shifted onto a belt conveyor. To avoid damaging the biscuits, the acceleration and especially the contact by the pusher must be very gentle. Moreover the speed of the shifted biscuits must correspond to the belt speed, so that the underside of the biscuit is not roughened by the belt. These problems are solved in very simple fashion by optimal motion profiles and a maximum speed limited to the speed of the conveyor belt.

## Stacking parts

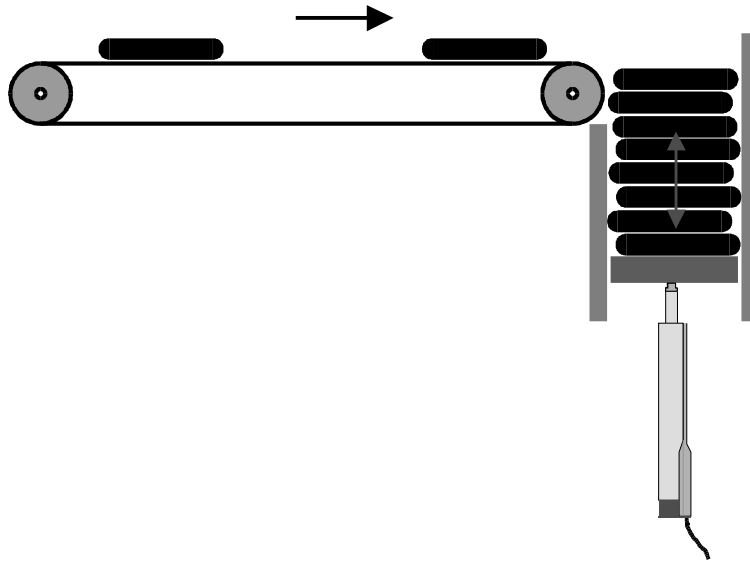

A wide variety of parts or biscuits must be stacked at the end of a belt conveyor. To handle the biscuits as gently as possible, the top edge of the stack should be exactly level with the height of the belt, or better - slightly lower. The draw-in motion of the vertical linear motor may be programmed as a relative motion with controlled acceleration, to prevent parts jumping back.

## Counting and separating

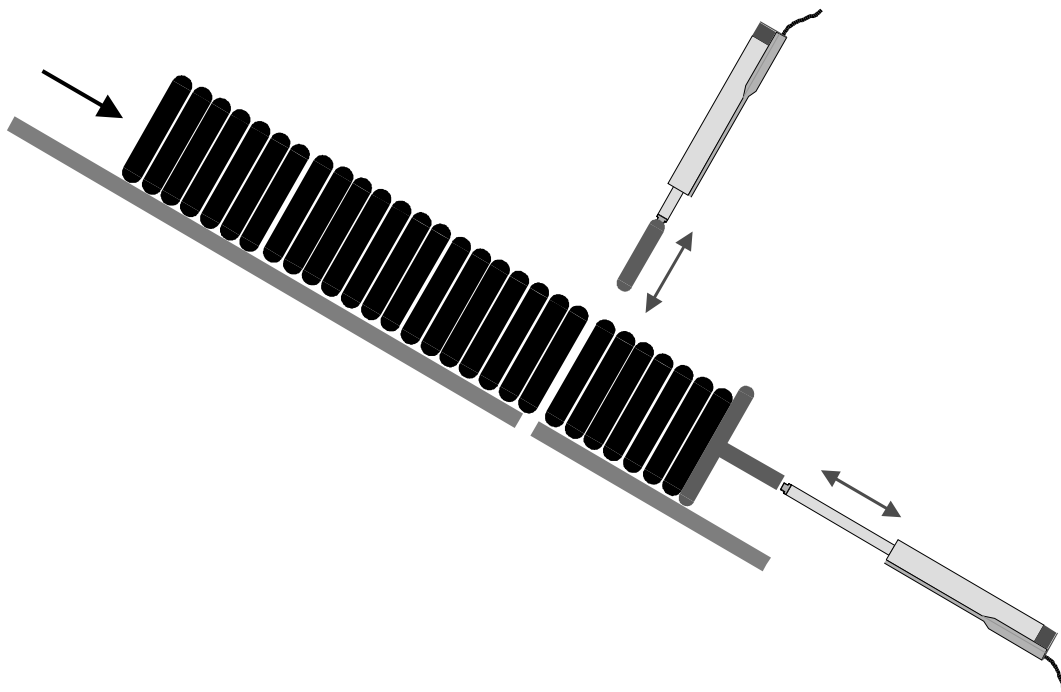

Parts in a line are to be counted off and separated. The horizontal linear motor moves slowly back by the desired length, so the parts arrayed can follow closed up. With the vertical motor a blade is inserted between the parts, separating them. The blade motion follows a profile that enables careful entry between the parts, followed by a rapid movement of the parts once the blade is properly placed between them.

## Picking up parts with a scoop

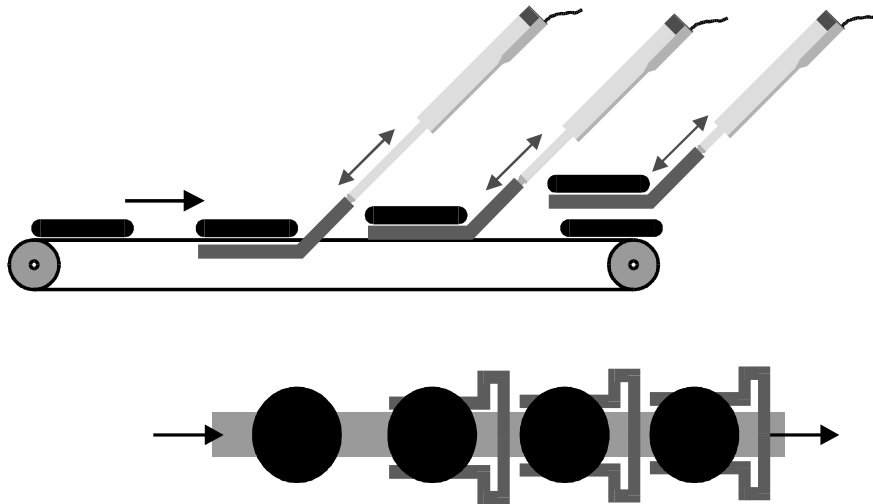

Parts are lifted from a belt conveyor with a split scoop. For this the scoop is moved up following a motion profile in the direction of the moving belt.

## Aligning and diverting boxes

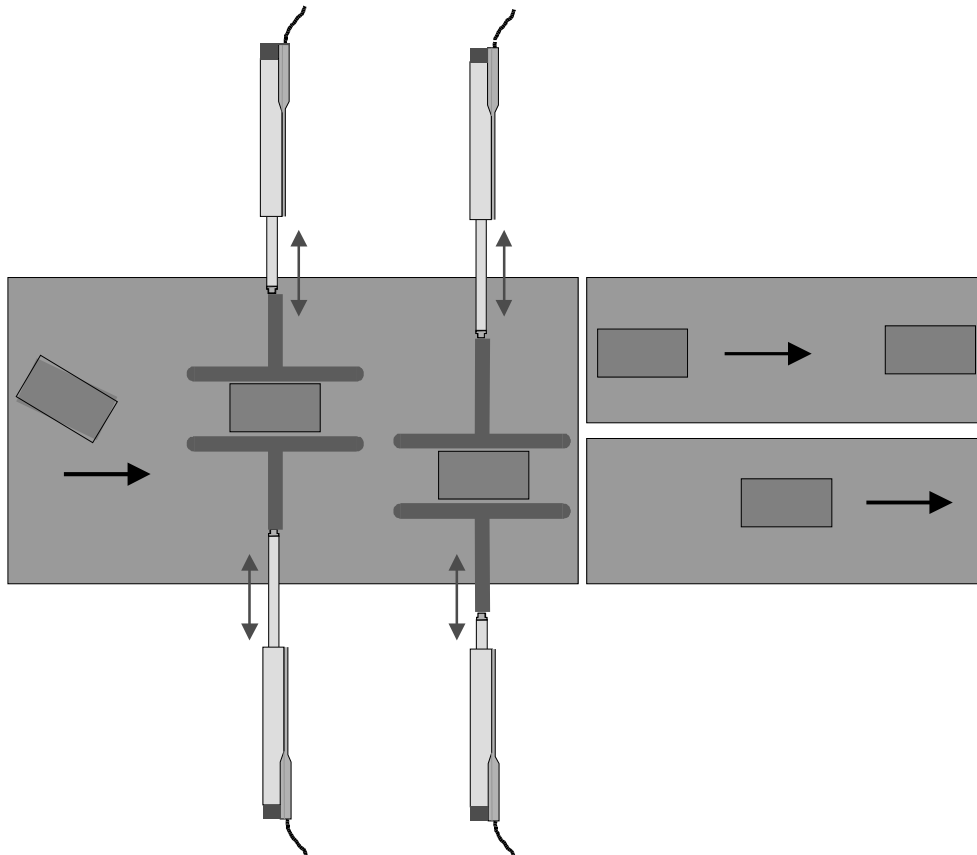

Boxes on a belt conveyor must be diverted onto two individual belts. At the same time the boxes are to be aligned. Two pairs of linear motors push the boxes to the appropriate side, aligning them at the same time. For this the motors are placed above the belt and fitted with vanes, allowing the boxes to pass through underneath the motors.

## Pneumatic grippers

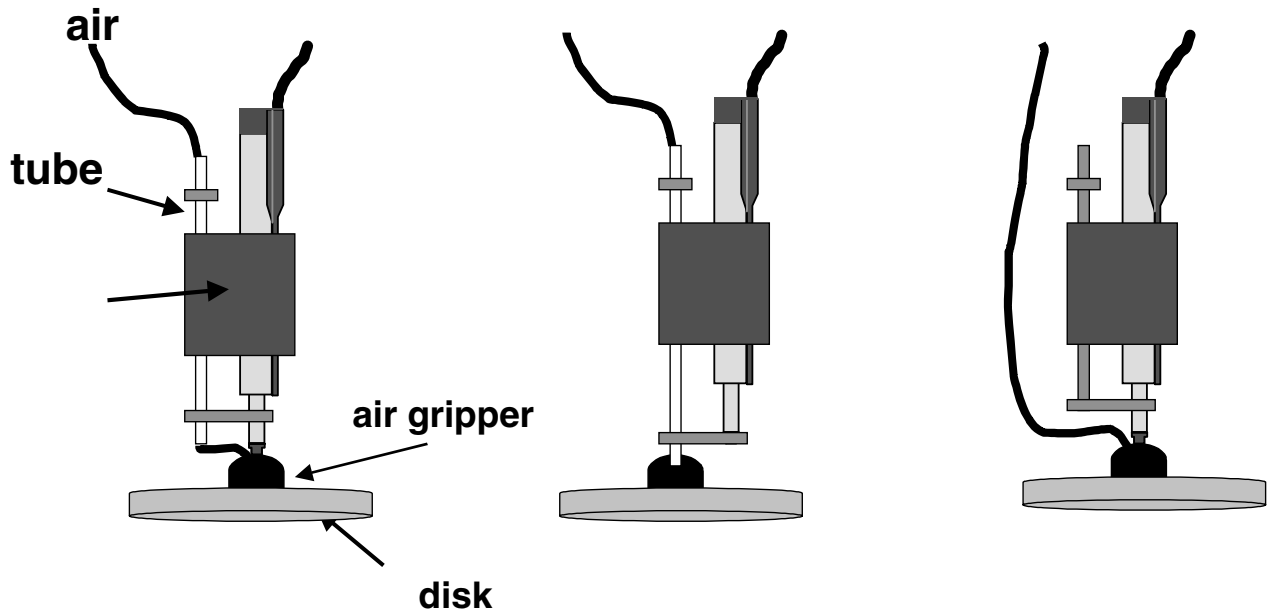

Pneumatic grippers may be fitted variously according to the application. Often the vacuum line is used at the same time as safeguard against twisting and falling-out.

## Linear and rotary motion

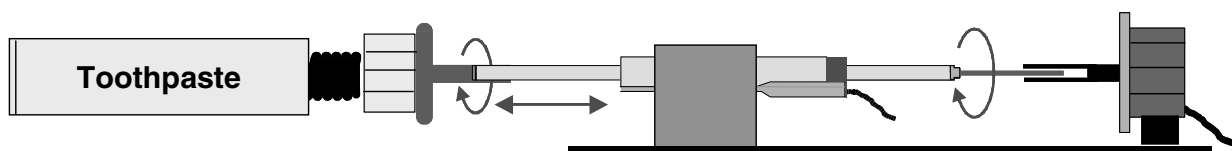

A combined linear and rotary movement is often needed for screwing-on caps of bottles or tubes. With LinMot linear motors this duty is very easily performed by using a long slider or extending the slider and coupling it to a rotary motor by means of a shiftable coupling. Neither the stator of the linear motor nor the rotary motor are moved. Only the slider with the coupling link to the cap is moved. On account of strength, only sliders with a minimum diameter of 20 mm should be used generally for this kind of application. Owing to the combined rotary and linear motion the positioning accuracy of the linear motor is reduced. When screwing-on caps, however, this is unimportant because here the linear motion of the thread is followed with a restricted force, and a rigid adjustment of the linear motion cannot be selected under any circumstances, otherwise the thread will be stripped.

## Assembly line combined with quality assurance

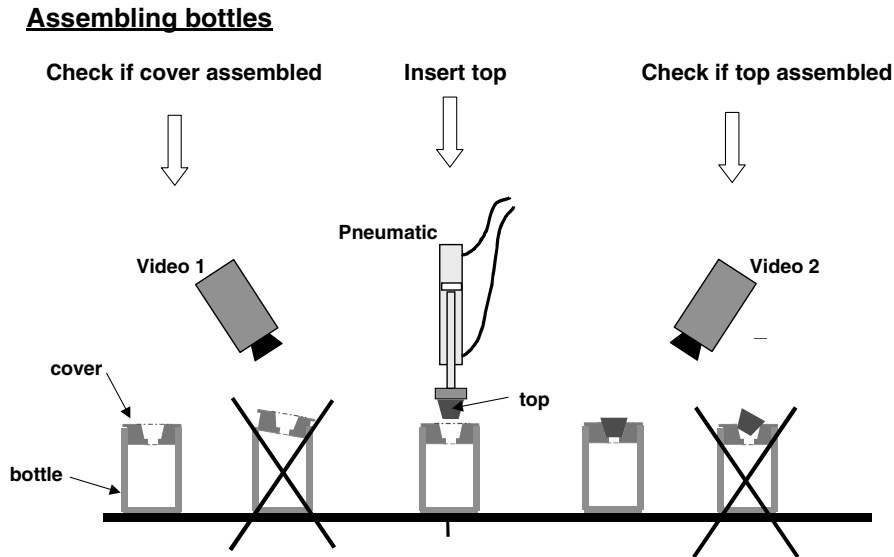

Containers are being put together on an assembly line (see above). A top must be pressed into a cover previously entered into the container.

The existing setup needed a visual testing system for this, to check whether the cover had previously been placed properly in the container. In a second step the top was moved to the cover by a pneumatic cylinder and then pressed into the cover. Because this operation was subject to errors and no feedback signal from the pneumatic cylinder was available for evaluation, a final check had to be made with a second image processing system.

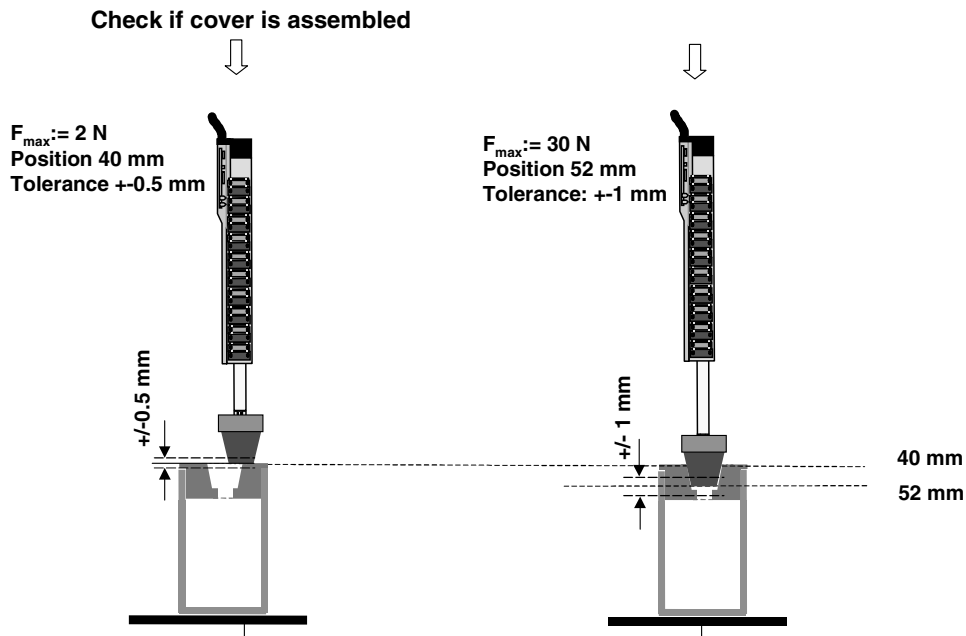

By employing a linear motor the entire process can now be greatly simplified and accomplished at much less cost (see above). First the linear motor is used as feeler. With little force the slider is moved onto a test stop of the cover. If the cover has been entered properly, the attainable end position will be about 40 mm. If this test (which replaces the first image processing system) is positive, the top is pressed in. For this it is brought before the opening in the cover with a rapid movement and then forced in at low speed under controlled force. The end position (52 mm) at which the slider is arrested may be used as control signal for the pressing-in operation. With that, the second visual system for the final check is likewise eliminated. Moreover much less space is claimed in the production line, because all functions are performed by one and the same linear motor.

## Pushing-in parts

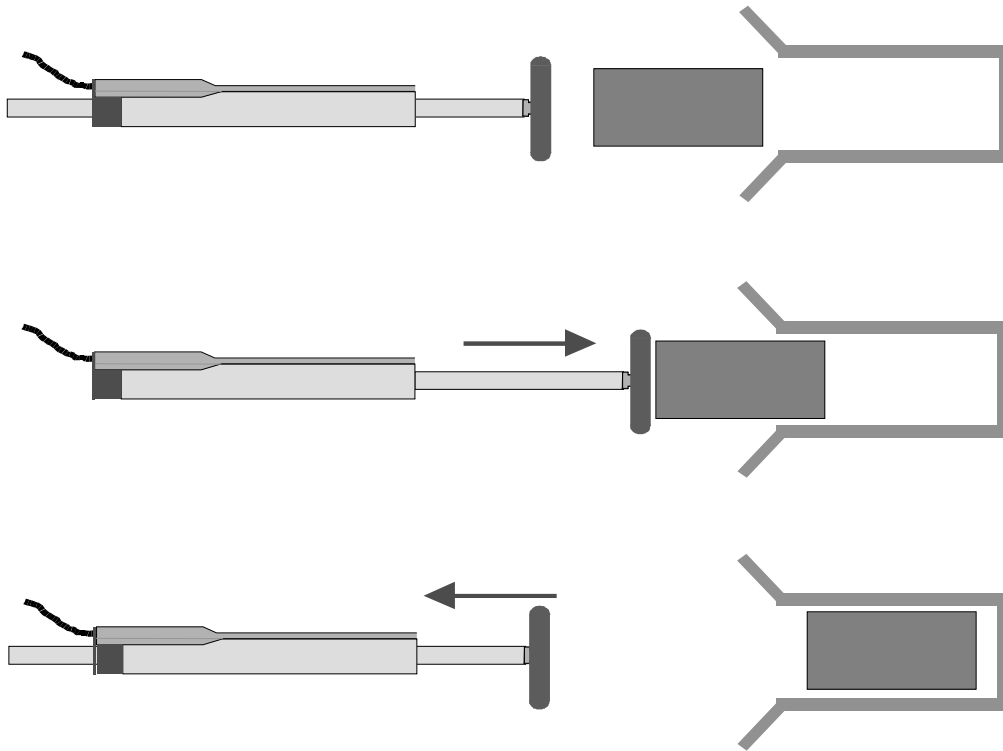

A frequent operation in packaging is pushing parts into a box or paper bag. By virtue of their geometry and high accelerations the LinMot linear motors are eminently suited for this kind of application.

## Gluing-on labels

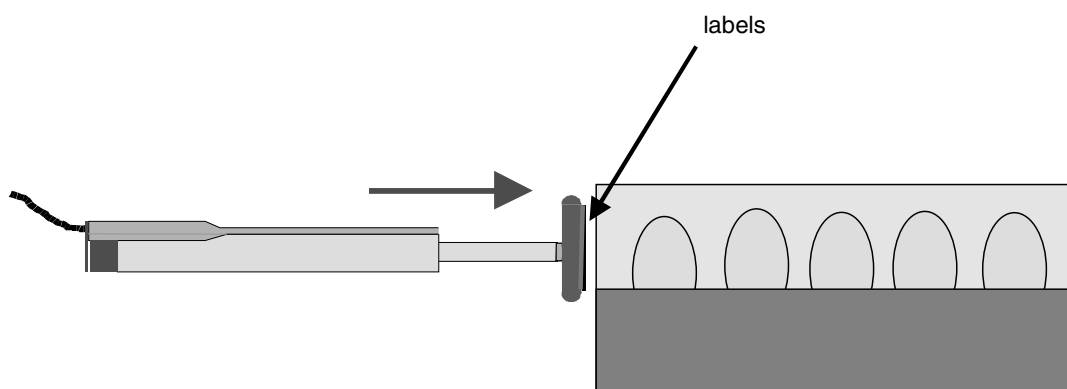

By exploiting the combined position and force controllability, labels of any kind can be stuck simply onto sensitive goods. The possibilities for flexible continuous path control and force limitation allow high cycling rates accompanied by improved quality.

## Printing inscriptions

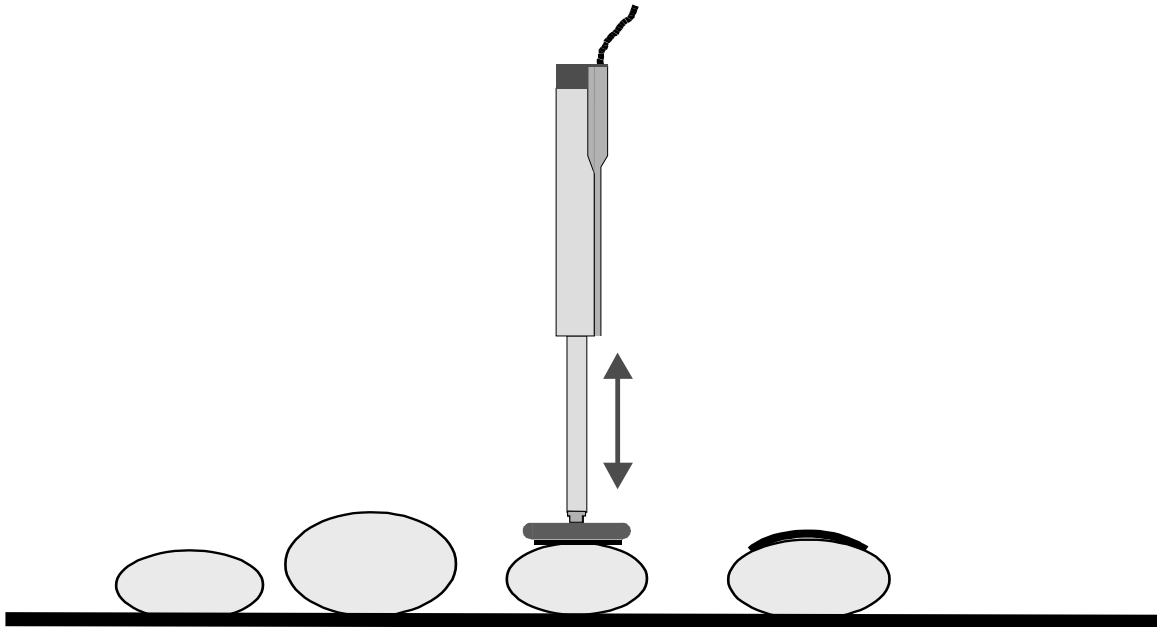

The capabilities of classical ink ball printing can be improved in terms of speed, gentle product handling and flexibility by employing industrial linear motors

## Testing switches

F1 --> OFF  
F2 --> ON  
s1 --> ON  
s2 --> OFF

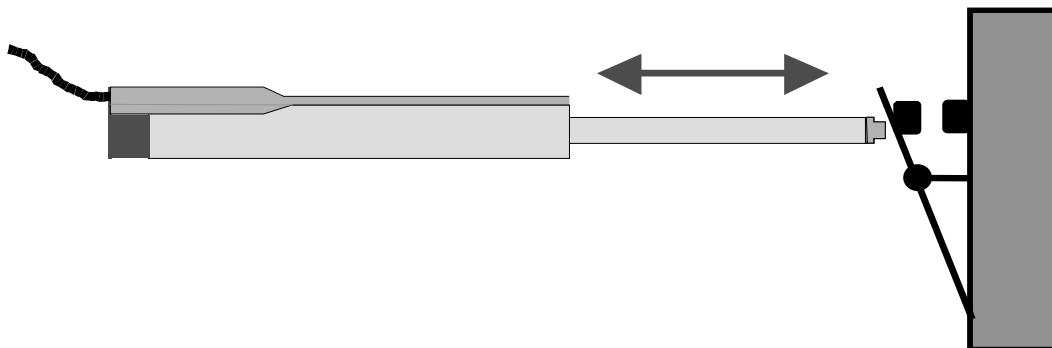

On a production facility switches are to be function-tested. Thanks to the force controllability of LinMot drives this task can be performed very simply. If very high accuracy is demanded in the force testing, a feeler head may be used as described in the section on designing. The force/displacement curve of a spring is then used to obtain an exact force adjustment from a corresponding position target.

## Applying coatings

$|v| := \text{const.}$   
 $a := \text{very high}$

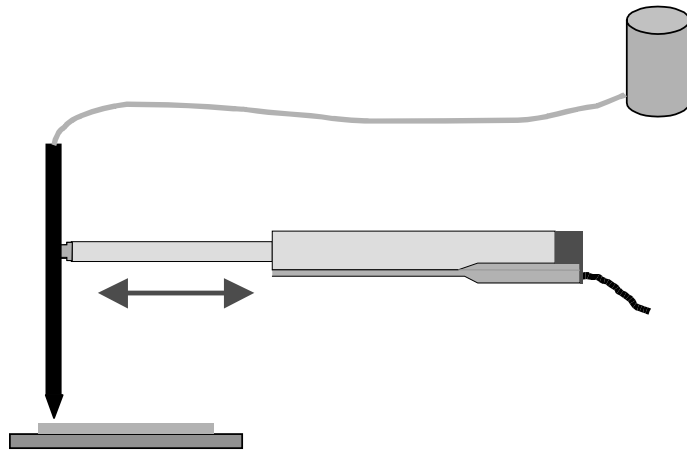
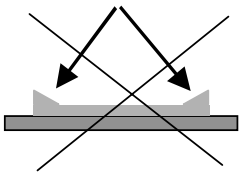

When spraying paints or other coatings onto a surface, there is often a problem in that the application rate is uniform and relatively slow but the change of direction at the two edges has to take place very quickly, otherwise there will be undesirable thickenings at the left and right boundaries of the working area. The wide dynamic range of LinMot motors can be exploited ideally for such applications.

## Coiling wires and winding threads

$|v| := \text{const.}$   
 $a := \text{very high}$

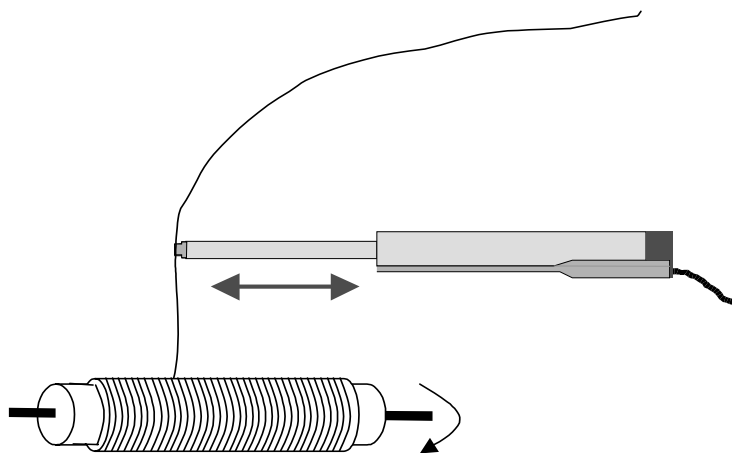
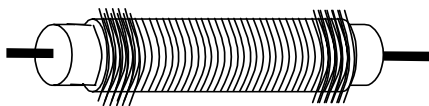

A problem similar to that encountered when applying coatings may arise when winding wires and threads onto spools or bobbins. This is often called the "dog's bone problem" on account of the undesirable build-up of material at the edges of the spool. The high accelerations of the LinMot linear motors enable this effect to be avoided, because the change of direction is extremely fast.



## Horizontal movement with preload

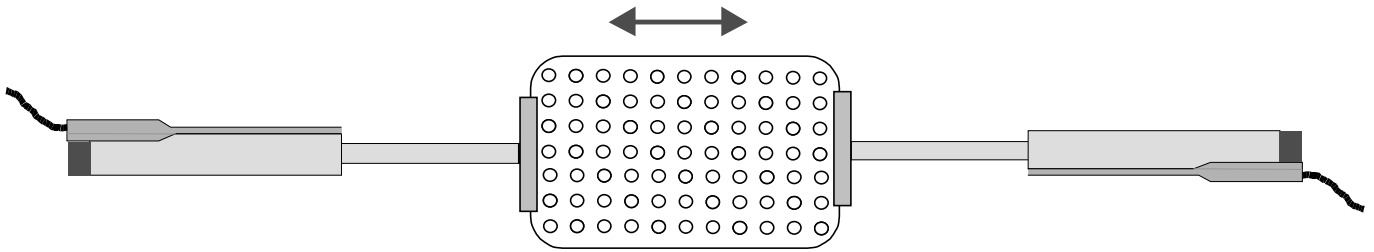

When flexible goods like tapes or films are to be displaced dynamically, it is often necessary to apply a preload to the product. This can be accomplished in very simple fashion using two linear motors, whereby depending on the application one motor is operated without integral controller action with a small position deviation or entirely in the force mode (force limitation or force regulation with special software).

## Applying a constant tension

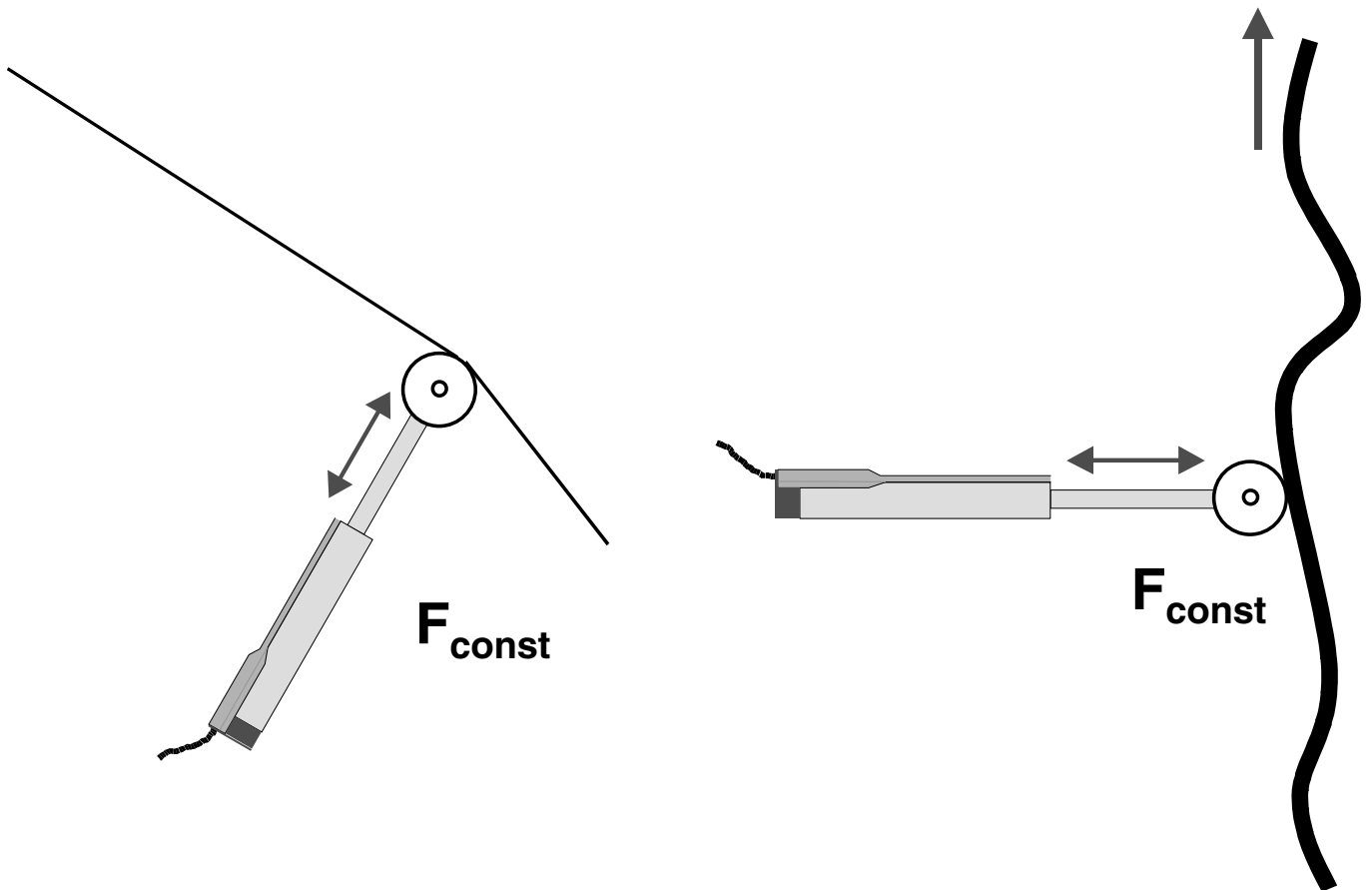

By virtue of the force controllability of the linear motors a constant force can be exerted over a wide stroke range. This capability may be utilized for example to keep wires under tension or to press rollers onto an uneven surface with constant force.

## Welding-on with constant distance to work

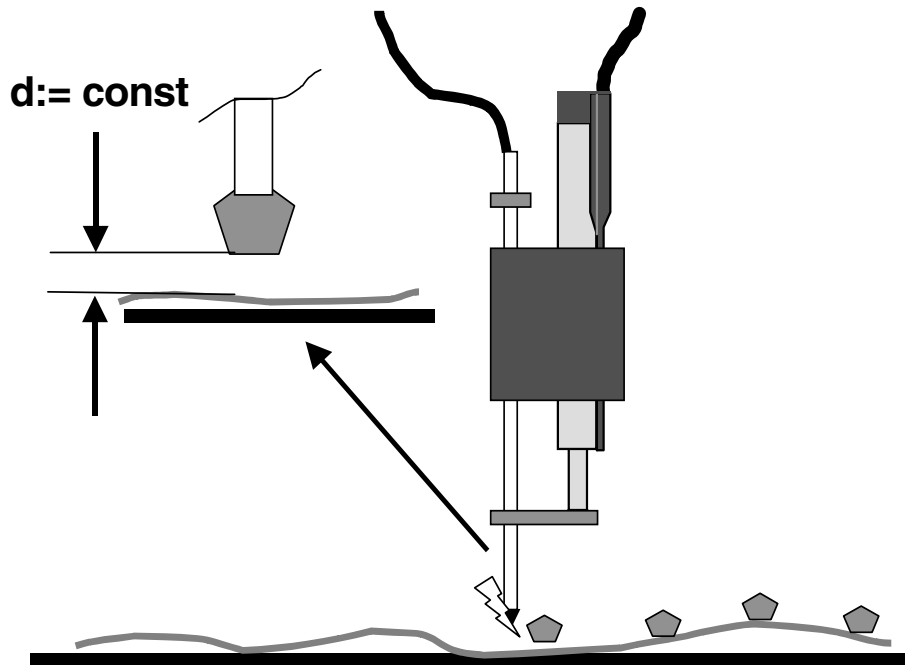

Parts are to be welded onto an uneven surface. Constant distance to work at the commencement of welding is demanded. With the linear motor the welding device is first lowered onto stop. The desired welding distance is then assumed by a relative reverse movement. Through this procedure unvarying process quality can be assured even if the surface is uneven.

## Inserting parts in injection moulds/tool changing

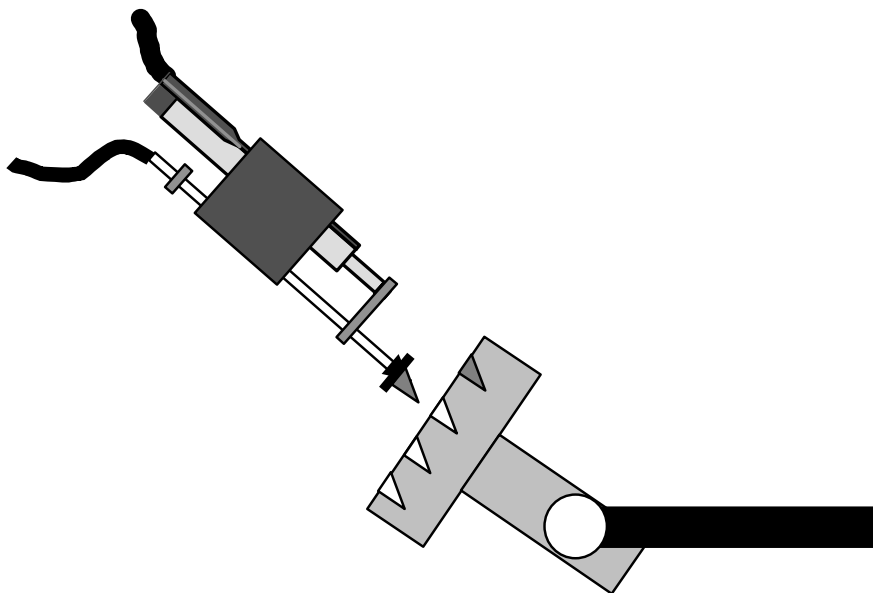

Owing to their free positionability and the ability to vary the force and speed setpoints, LinMot linear motors are eminently suited for inserting parts in injection moulds or placing tools in machines. The parts are brought with rapid movements till shortly before the required position and then inserted carefully. The force controllability together with the position feedback make possible a 'groping' motion sequence similar to that of a human hand.

## Braking (damping) parts

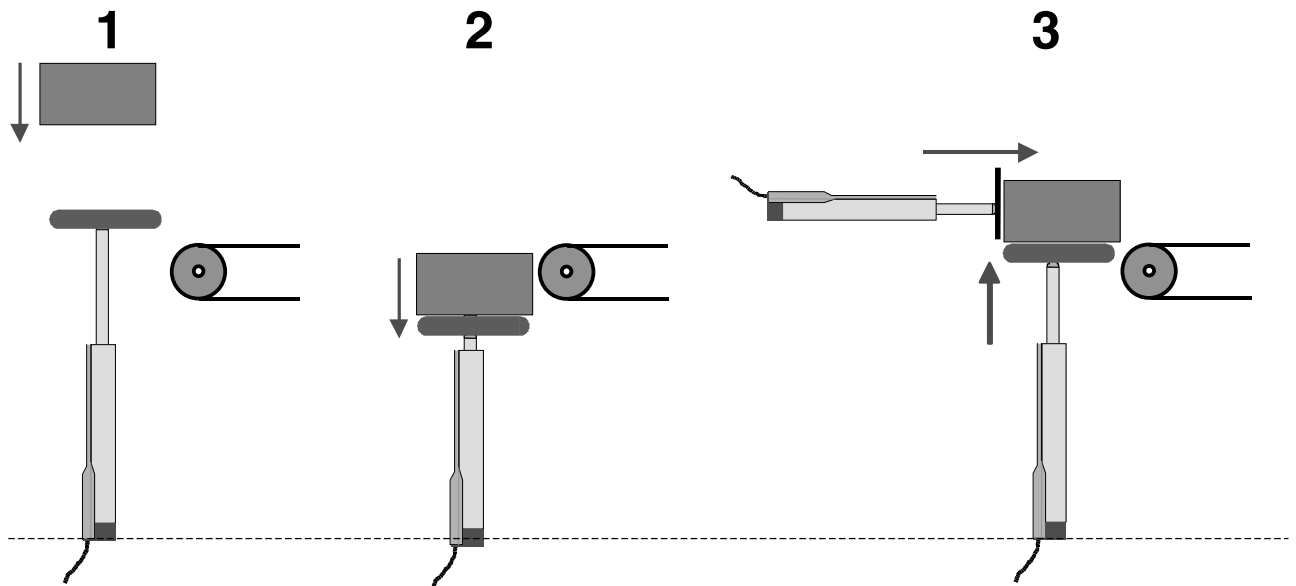

Gentle braking of boxes can be assured by means of the force limitation and/or a soft controller setting for the LinMot linear motors. After braking, the boxes can be moved to a desired starting position for further processing using the same linear motor.

## Vibration testing

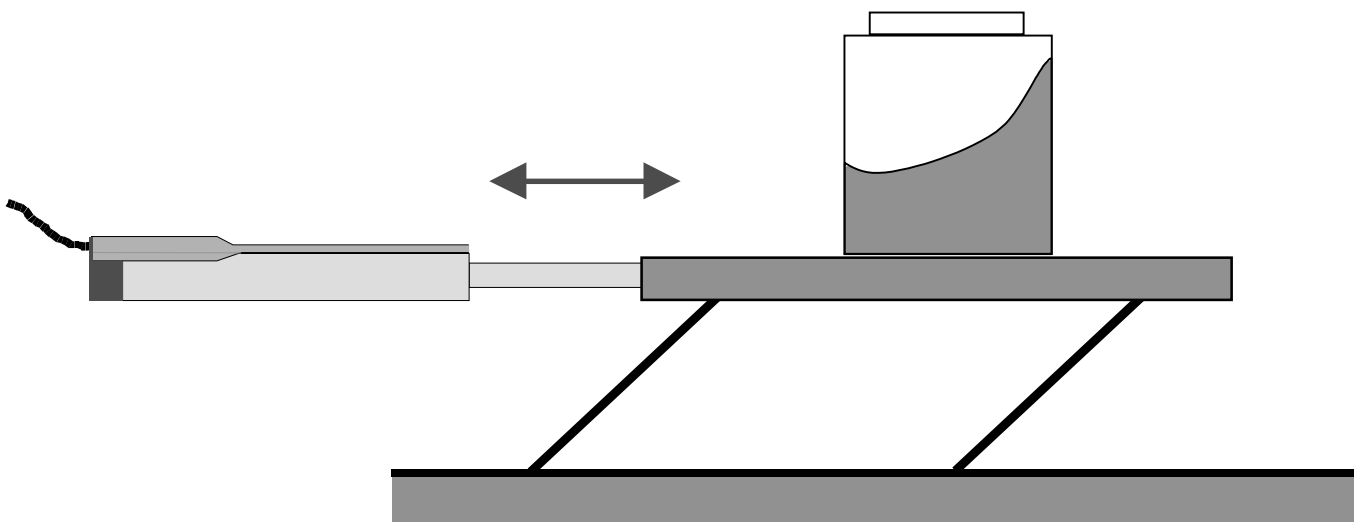

Test rigs for vibration and shock testing can be assembled with LinMot linear motors. The physical limits for acceleration and frequency are lower than those of vibration testing apparatus designed specially for this purpose; nevertheless they are quite adequate for various applications.

## Auxiliary drive for servosystems

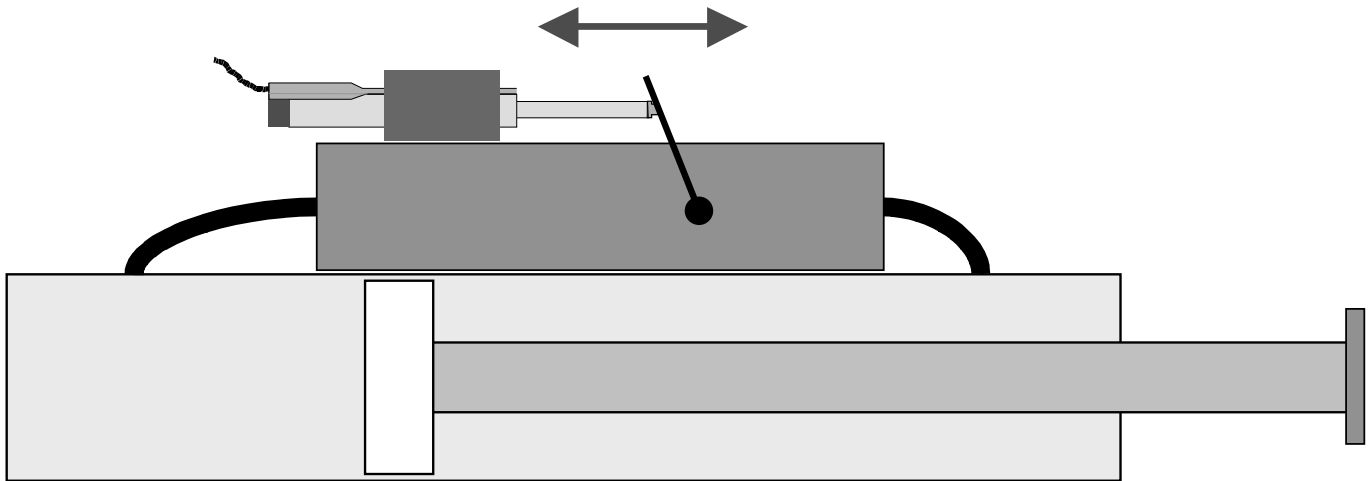

**Hydraulic cylinder**

Industrial linear motors serve as auxiliary units for controlling hydraulic servovalves.

## Controlled immersion of parts in liquids

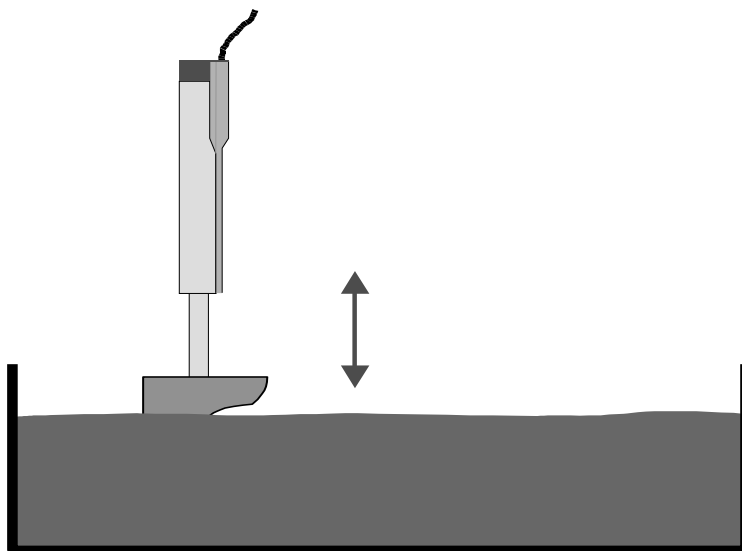

When dipping parts in a liquid it is often necessary to perform the immersion and withdrawal under tight control. These in and out movements are often carried out at very different speeds, or else splashing must be avoided. Here too, motion profiles enable optimal adaptation to the situation (e.g. fast approach, slow immersion till the surface tension of the liquid is overcome, rapid complete immersion).

## Moving stator

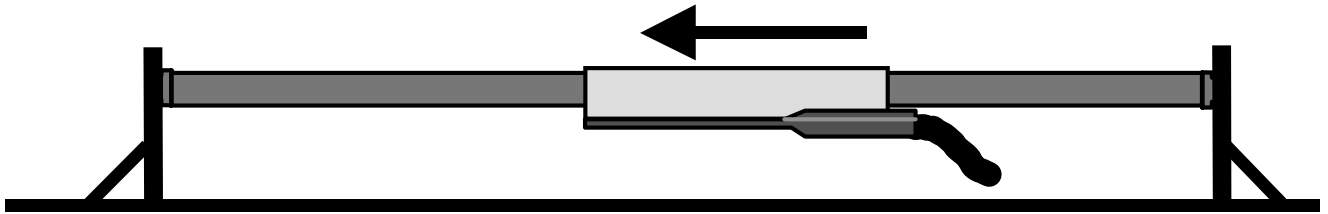

For longer strokes it may be advisable to fix the slider rigidly and move the stator. In such cases it is usually necessary to provide an additional guidance for the stator, especially if greater masses are to be moved by it. A special highly flexible cable lead is used, which should be led in a trailing chain. On account of mechanical strength, only sliders of at least 20 mm diameter are generally suited for such arrangements.

## Two moving stators on one slider

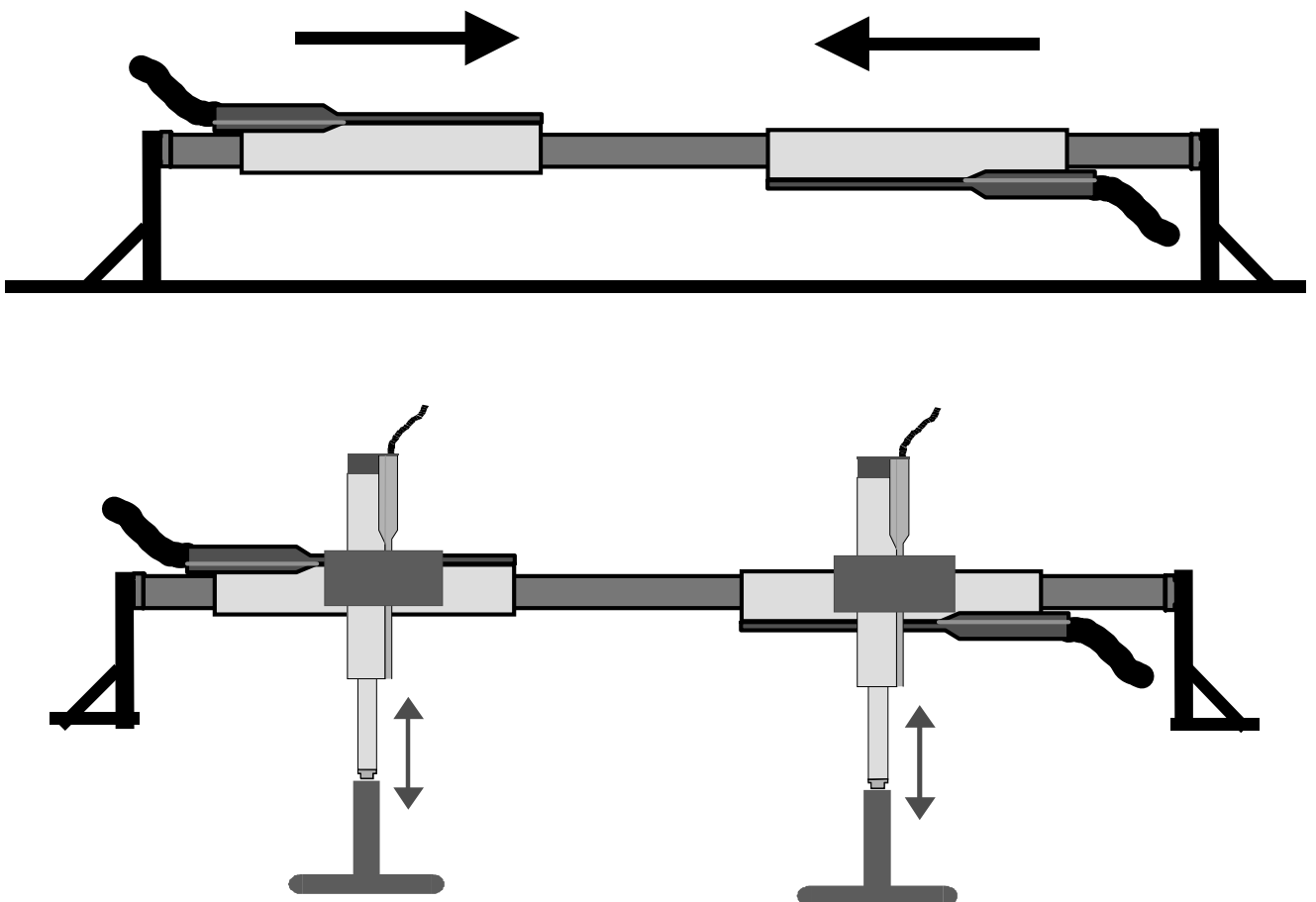

A particularly space-saving configuration results if two independently controlled stators are moved on the same slider. A typical application is where parts have to be delivered from a belt conveyor to the left and right.

## Paralleled motors

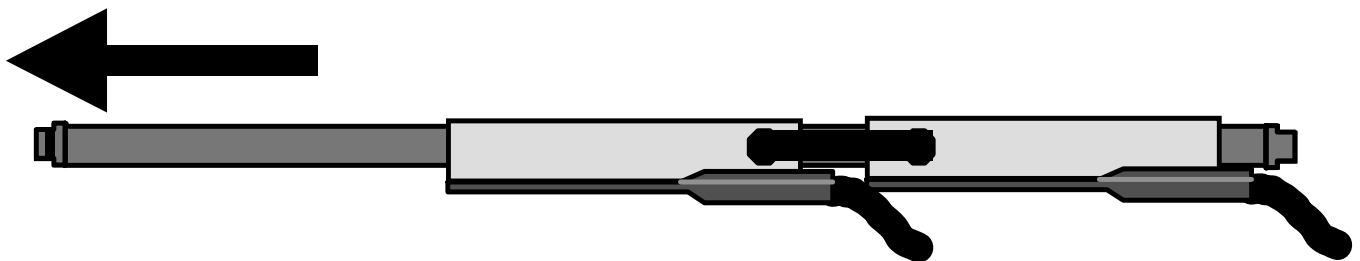
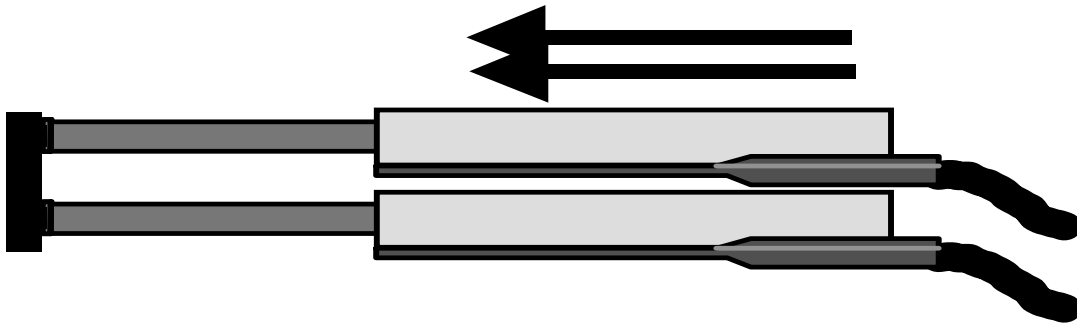

Up to four motors may be connected in parallel, providing four times the force of a single unit. Paralleling involves a simple mechanical coupling. The drives may be arranged side by side or one after the other on the same slider.

# Pictures of applications

## Parallel kinetics

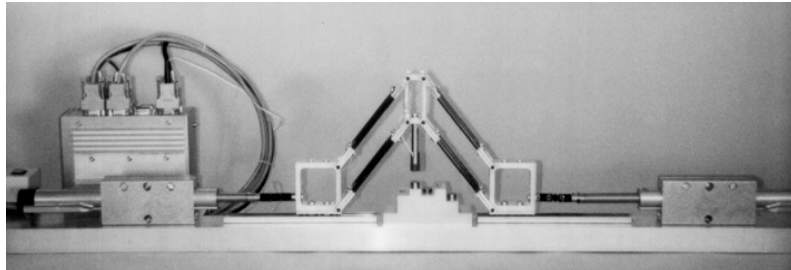

The high dynamics of linear motors, plus the possibility of parallel kinetics, can yield interesting results. No doubt the classical XY arrangement will be the answer for most general applications in the future too. Nevertheless current robotics research is extending continuously the possible applications for parallel structures.

## Two stators on one slider

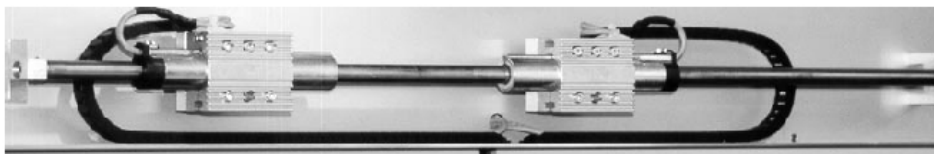

The use of two independently moved stators on one slider is advisable above all where a very narrow assembly is demanded on account of space. For example, it enables parts to be delivered left and right from a belt conveyor.

## Packaging machine for biscuits

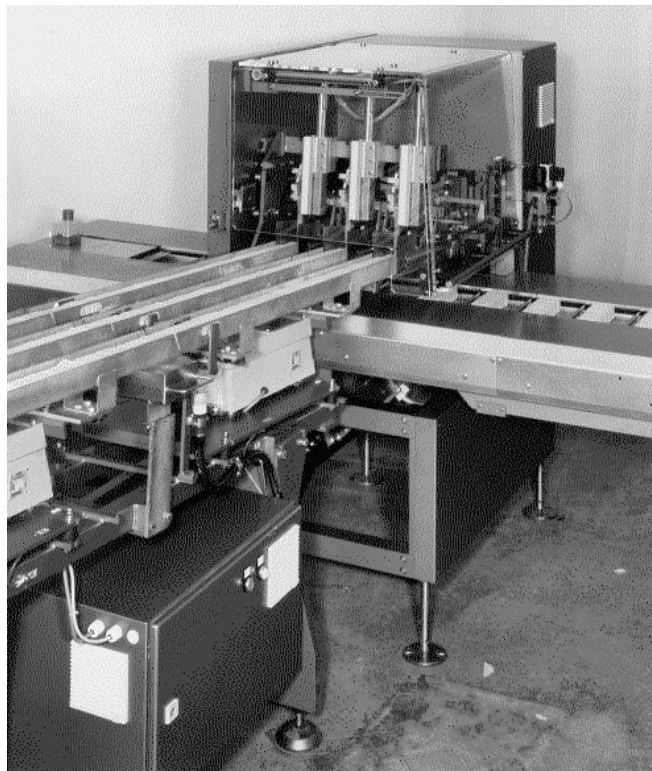

(SIG photograph)





(SIG photograph)

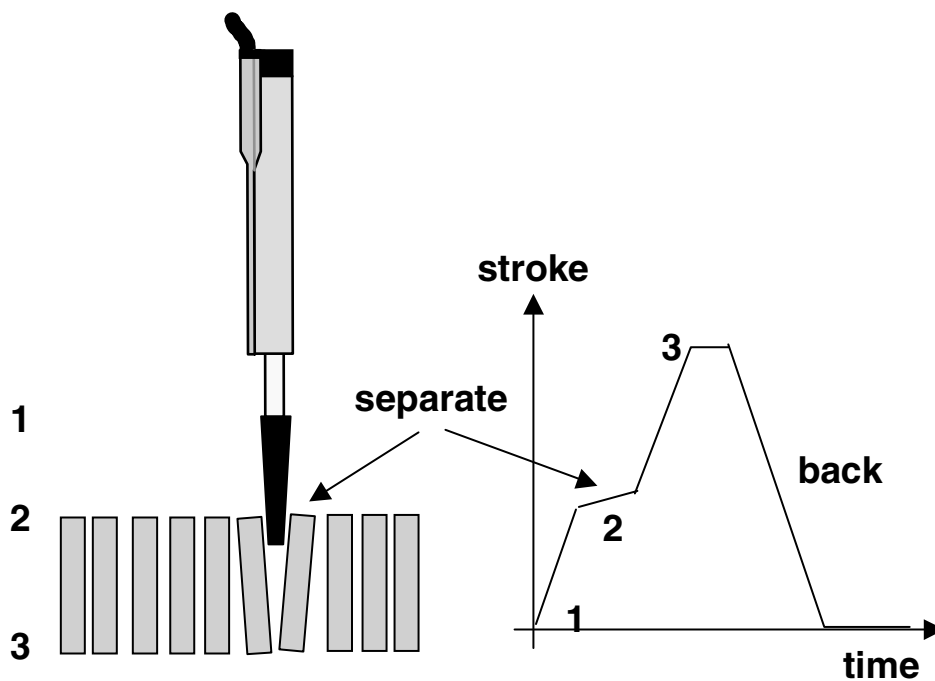

The linear motors enter a blade into a row of biscuits and separate them. For this the blade fixed to the slider (see diagram) is moved rapidly to the biscuits (1), slowly and carefully introduced between them (2), and then moved rapidly right down (3). The return movement can also be performed very fast, as no damage to the biscuits is to be expected now and the production speed may be raised. Plotted in the diagram is the motion profile run off by the linear motors in this application. The actual part sections of the profile are in fact run off in the form of S curves to ensure motion sequences as smooth as possible.

## Introducing single biscuits

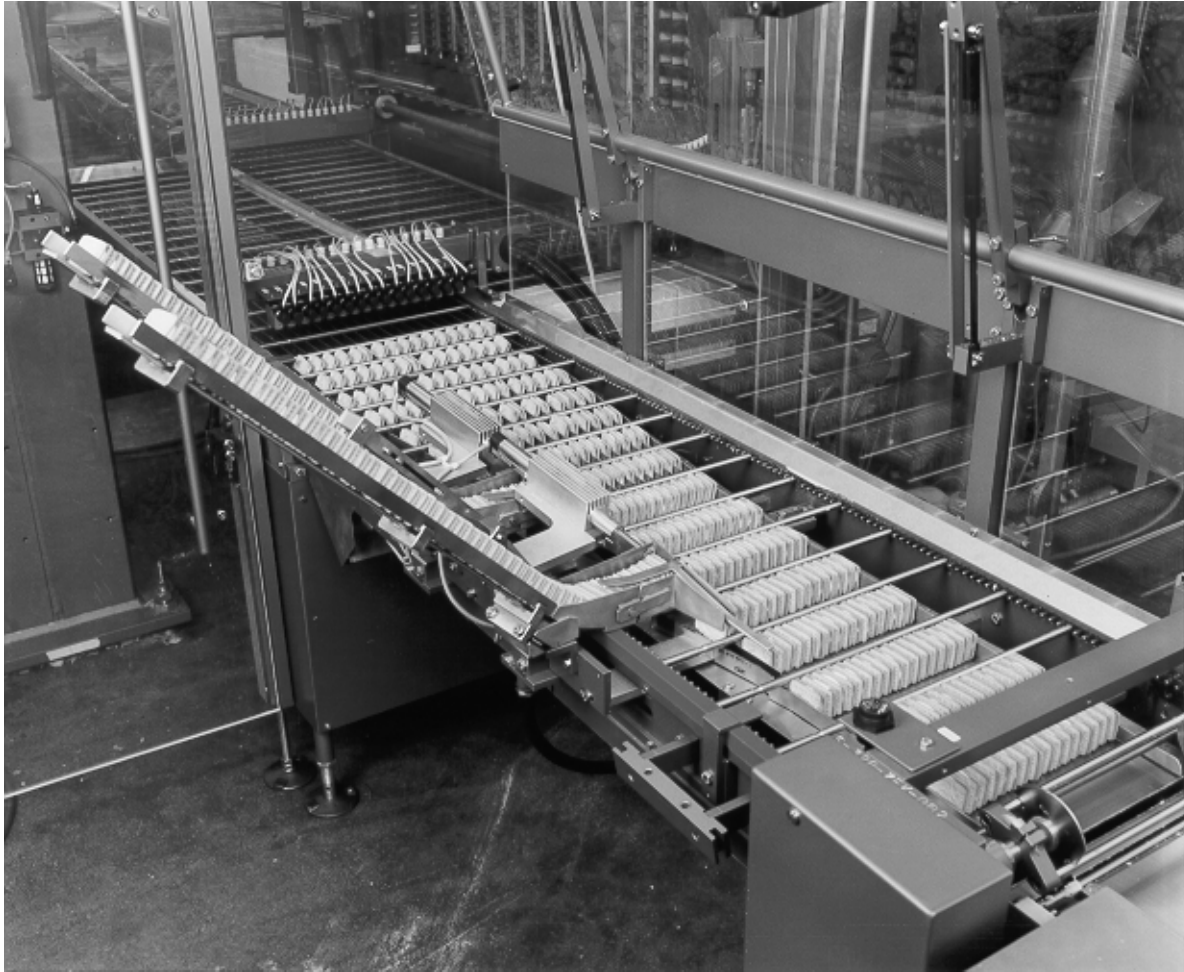

(SIG photograph)

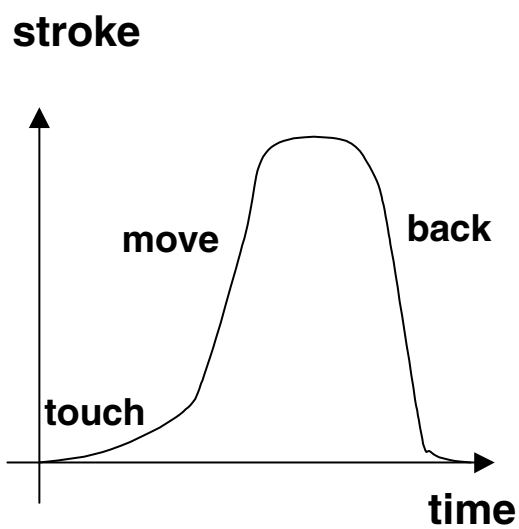

In this application, individual biscuits are introduced very quickly yet very carefully. Crucial here are the exact controllability and regulability of the linear motors and the choice of a suitable motion profile. It will be clear from the diagram that the linear motors touch the biscuits slowly and then accelerate rapidly, before returning very rapidly to their starting position.

## Damp and dirty working environments

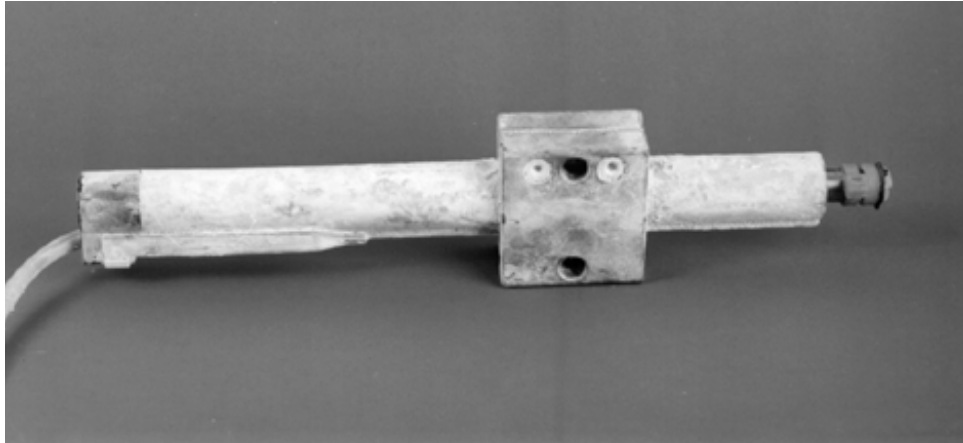

LinMot linear motors may be employed in very dirty working environments because both the sensors and their electronics are bedded entirely in protective material. The picture shows a completely encrusted motor, with lime deposits as well as moss growth. With such applications special attention must be given to the idle periods also. If the motor is not operated for some time, encrustations like this may form between the slider and stator too, preventing the motor being restarted in the extreme case.

## Synchronizing belt conveyor levels

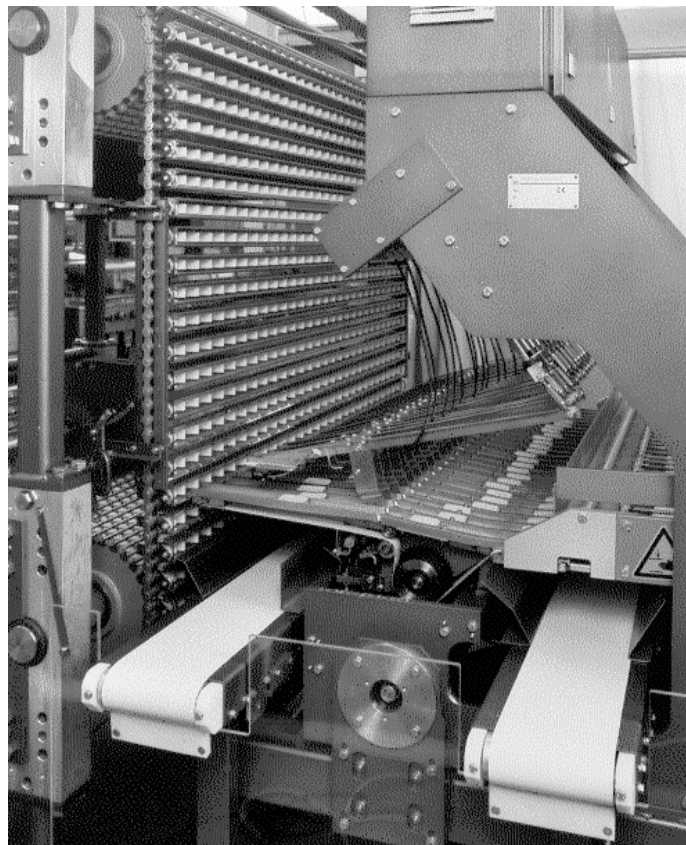

(SIG Pack photograph)

In this application 24 linear motors are being used. They serve to move up and down small belt conveyors placed very close together. This enables the biscuits delivered at irregular intervals to be filled without gaps into the small boxes of the intermediate storage.

# Designing

## Slider couplings

For coupling the slider to the part that is to be moved (e.g. gripper, scoop, switches etc.) there are two basic alternatives:

- screwing, using the holes provided at the ends of the slider
- clamping, on the ends of the slider

If the machine part to be moved is also in bearings, the basic rules for mechanically coupling two parts in bearings must be observed. If necessary provision must be made for parallel or angular misalignment (i.e. flexible couplings). When selecting a coupling, always bear in mind that the slider should sustain the smallest lateral forces possible, so that friction is minimal.

### Rigid coupling by screw connection

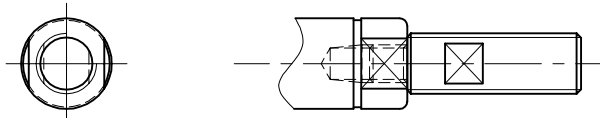

Typical coupling of a slider extension or feeler head to a slider by means of the hole provided in the end of the slider.

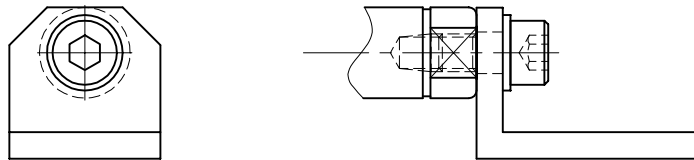

Angle fixed by screwing.

### Rigid coupling by clamping

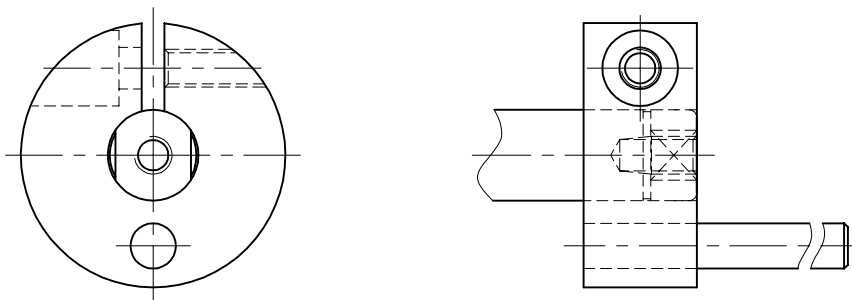

Coupling to the slider can be effected by means of a force-fitted clamp connection at the ends of the slider. The clampable length at both ends of the slider is 15 mm on motor type P01-23 and 22 mm on type P01-37.

## Flexible couplings

### Compensating axial and angular misalignment

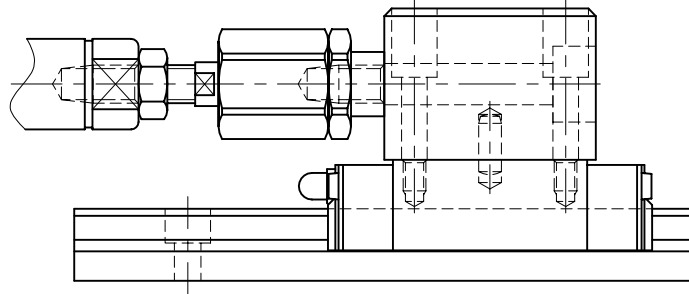

Axial and angular misalignments can be compensated in very simple fashion. The above sketch shows how a slider is connected to the carriage of a standard guide using a connector of this kind supplied by Festo. Such compensators are supplied by nearly all makers of pneumatic equipment (see page 49).

### Compensating axial misalignment

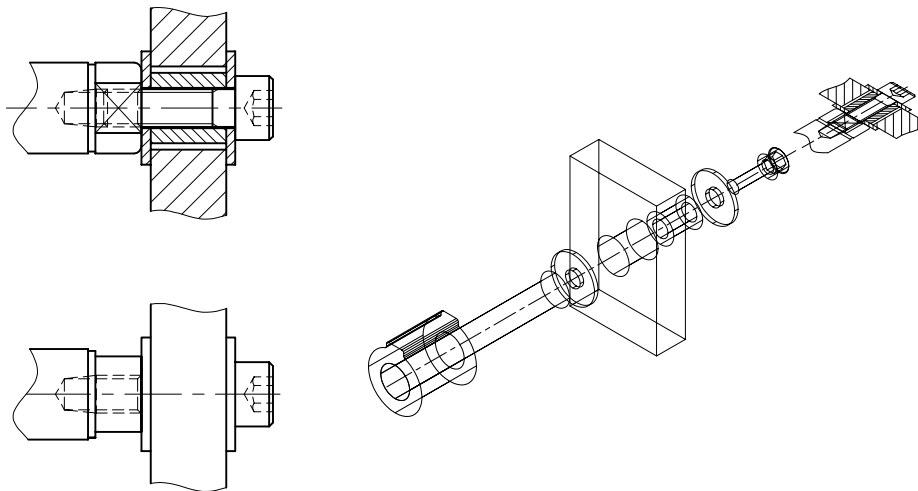

Axial misalignment may be compensated by means of a design as shown above. A sleeve is employed as spacer and introduced into an oversized hole, so that the slider may move radially. Depending on the application, the unavoidable axial play of this design may be a disadvantage.

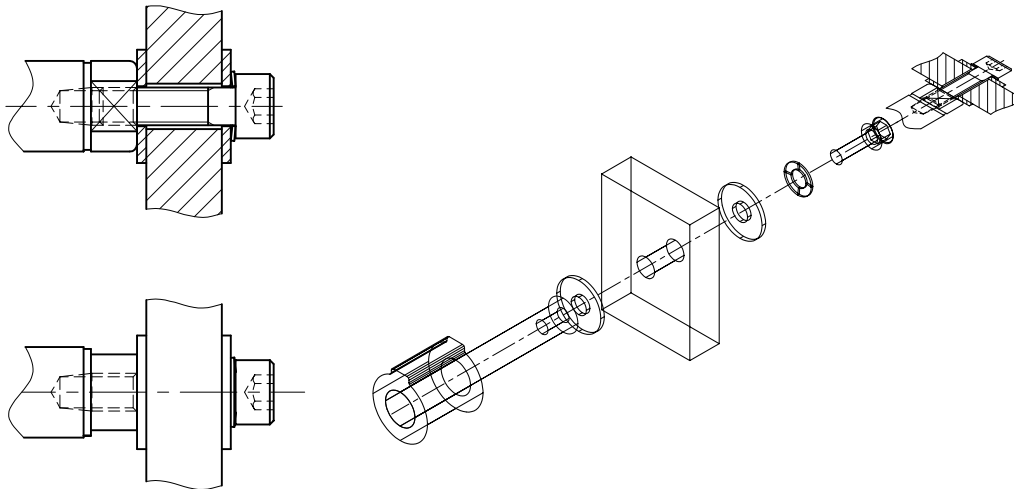

The axial play can be reduced by means of a disk spring.

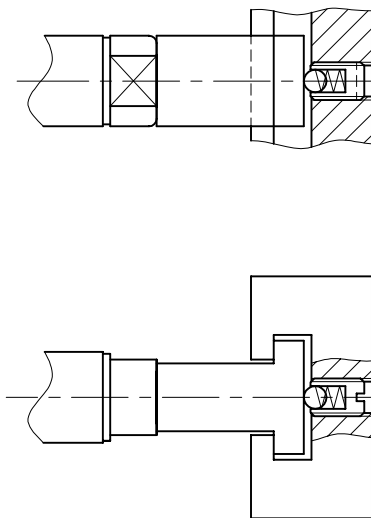

The force may be transmitted also with a T piece fitting in a slot. If necessary a preload may be applied by means of a spring, whose force can be adjusted with a set screw.

## Twisting and fall-out safeguard

The sliders of the LinMot® P family can be moved freely when without current. They can also be turned during operation. Both capabilities make possible interesting designs (e.g. linear motion combined with rotation), but they are not optimal for every application. The designs following show how a safeguard against twisting or dropping-out or both can be provided in simple manner. Further possibilities result where external guiding systems (see section on supplementary guides) or electrically operated brakes are employed.

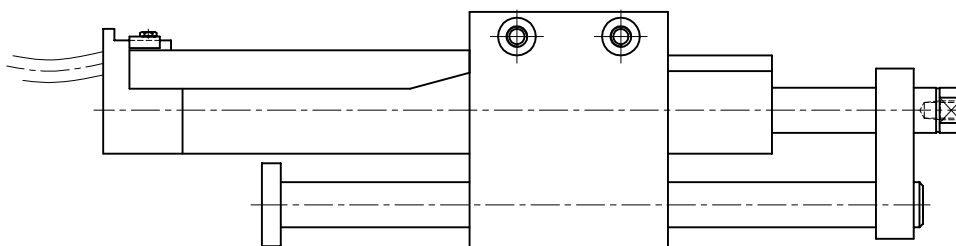
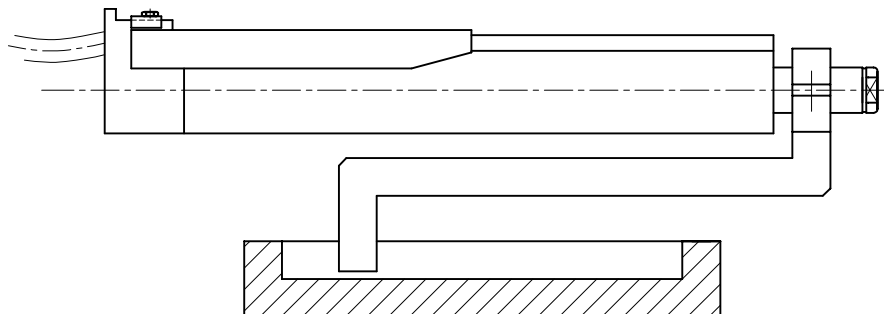
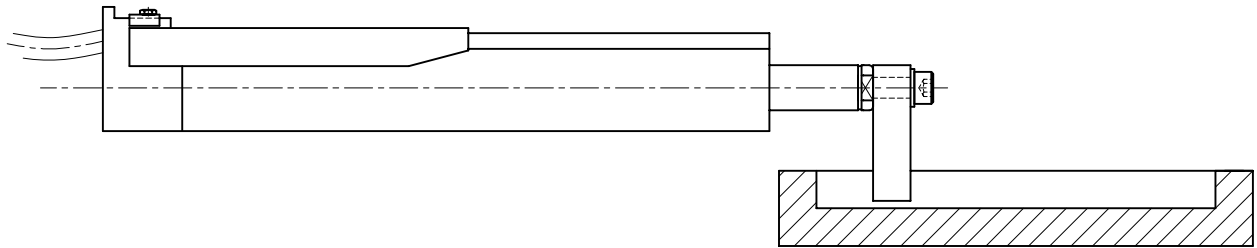

## Ways of fixing the motors

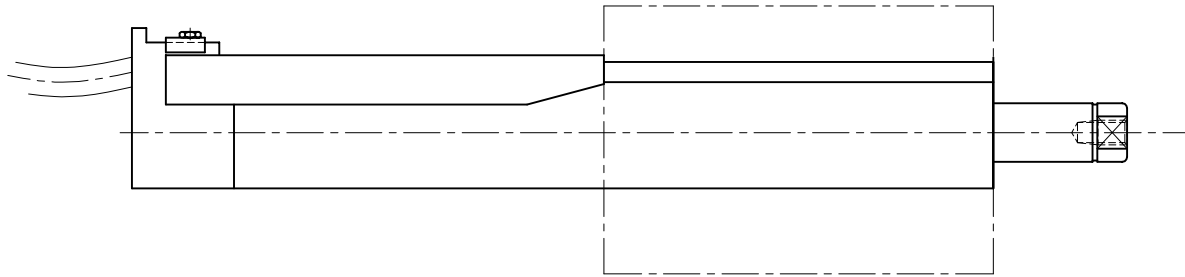

LinMot P motors are fixed by means of a clamp connection. This has the advantages of flexibility and small size, because it is not tied to a given motor flange. Whenever possible the biggest clamp connection possible should be used, in order to obtain optimal cooling of the motors. Additional cooling fins or even forced air cooling by fan can raise the output power (continuous force) of the linear motors substantially.

### LinMot standard flange

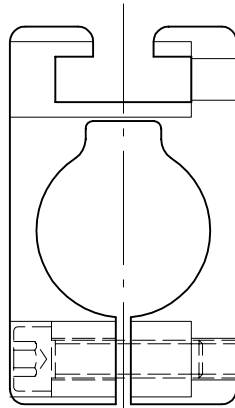

With the standard fixing flange supplied by LinMot(R) (cf. products, page xx) the motor may be clamped with two screws. The flange is available for all motor sizes. Grooves are provided for fixing the flange to a stationary machine part.

### Alternative clamp fastenings

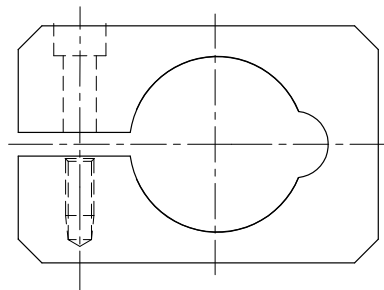

A clamp fixing may be made from a piece of aluminium as sketched above (the recess on the right is predrilled as a hole).



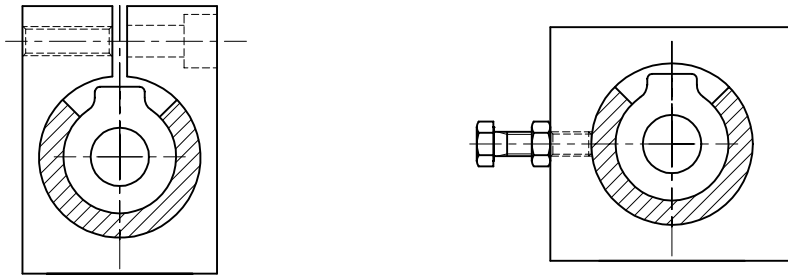

Very easy to produce is a clamp fastening consisting of a round hole and a ring segment as shown above. Clamping is achieved either by a slot which is pressed together or by screws forcing the metal ring together.

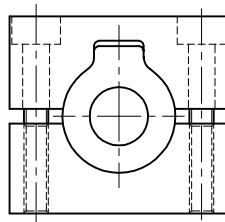

Another possibility is to make the flange in two parts. The two halves and the recess for the groove can be milled.

## Supplementary guides

Additional guiding is usual in applications involving:

- long displacements
- high lateral forces or large load masses
- a need for very exact motion guidance

Supplementary guides may be used also as safeguards against failure and/or twisting.

Below it is shown how different guiding systems may be used with LinMot motors.

### Linear guiding (recirculating ball units)

Makers of recirculating ball units include INA and THK. Page 50 and 51 give part of their product ranges. Recirculating ball units consist of a rail and the carriage running along it. Quite big forces can be taken up by small guides.

#### Guide in the motor extension

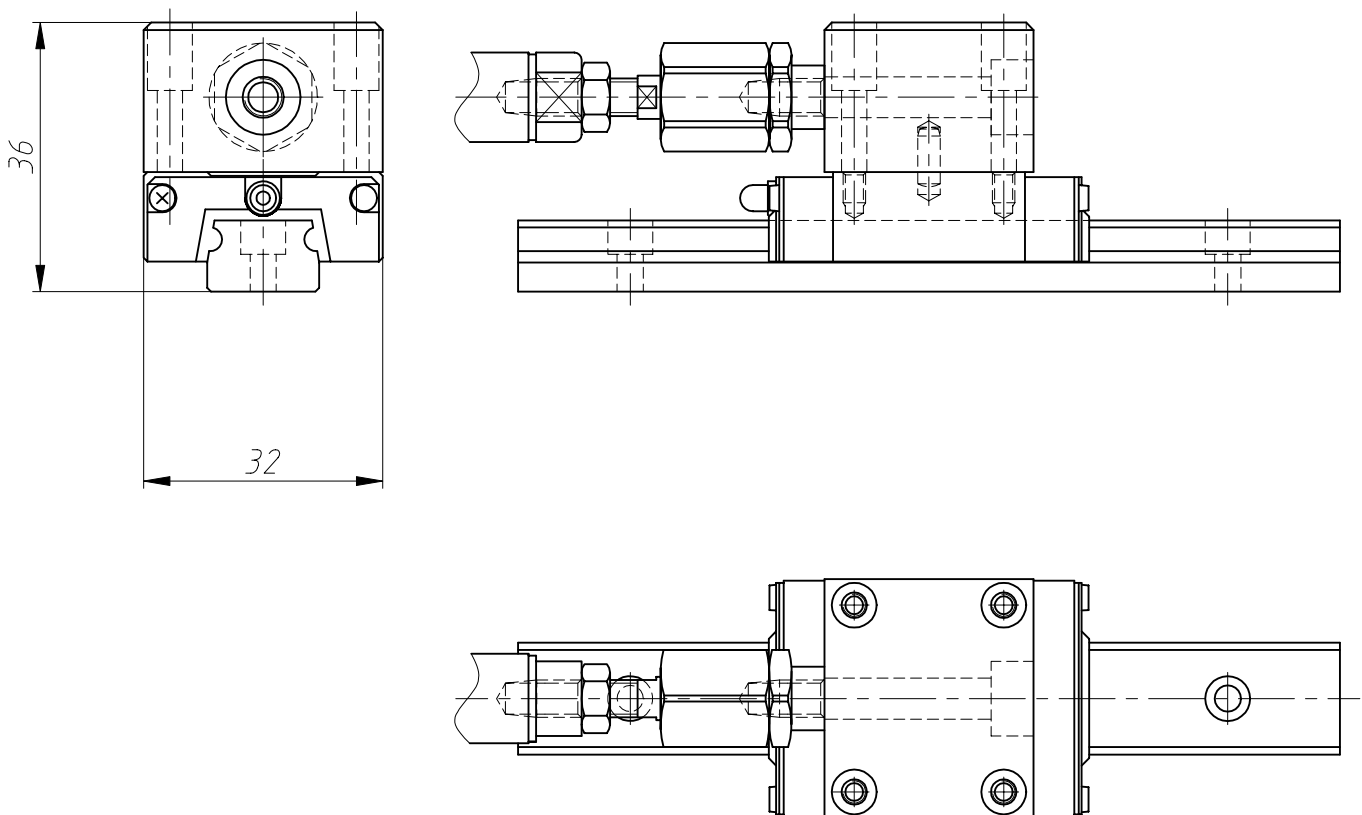

The recirculating ball unit may be fixed in the motor extension. To avoid having to align the motor and guide exactly, a flexible coupling may be used as joining element to compensate any axial and/or angular misalignment.

## Guide fitted on LinMot standard flange

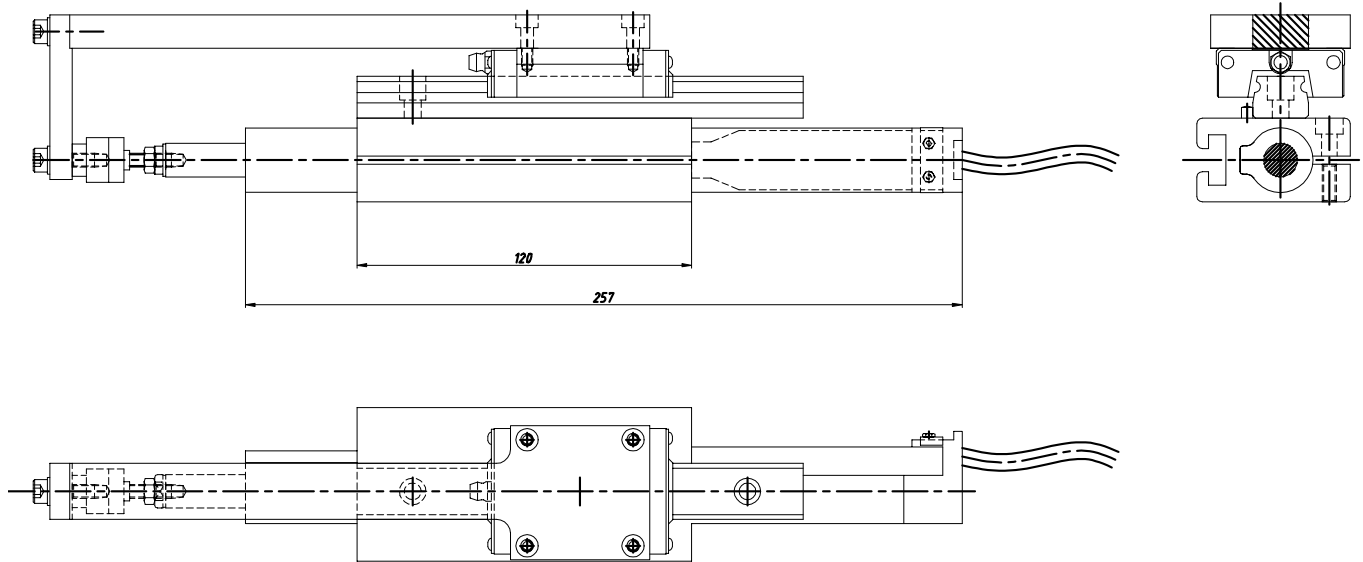

A compact unit is achieved by fitting the guide straight on the motor flange. Depending on the design it may be possible to do without a compensating element altogether.

### Shaft guides

The design shown here is an extremely compact way of guiding an external load, and is often used in pneumatics too for example. The two guiding shafts do not take up any more space as they are placed just beside the motor and move together with the slider. Shaft guides do not have the same precision as the guides with carriage and stationary guiding profile described previously, and they cannot accept the same high lateral forces. Nevertheless the compact layout and integrated twisting and fall-out safeguard in the form of an H profile often make shaft guides the preferred solution. For all motor sizes there are various designs based on standard elements of outside firms or produced in-house.

#### Festo guide unit for motor type P01-23

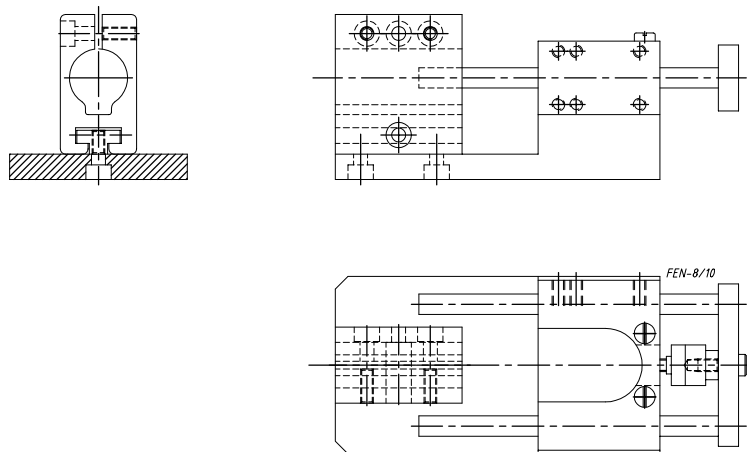

For the P01-23 motor type the FEN-8/10 guide unit supplied by Festo AG may be used (see section on accessories). The through hole for the slider must be enlarged to 20 mm diameter, otherwise the motor with a standard flange and the guide may be fixed in alignment on a basic unit.

#### Festo guide unit for motor type P01-37

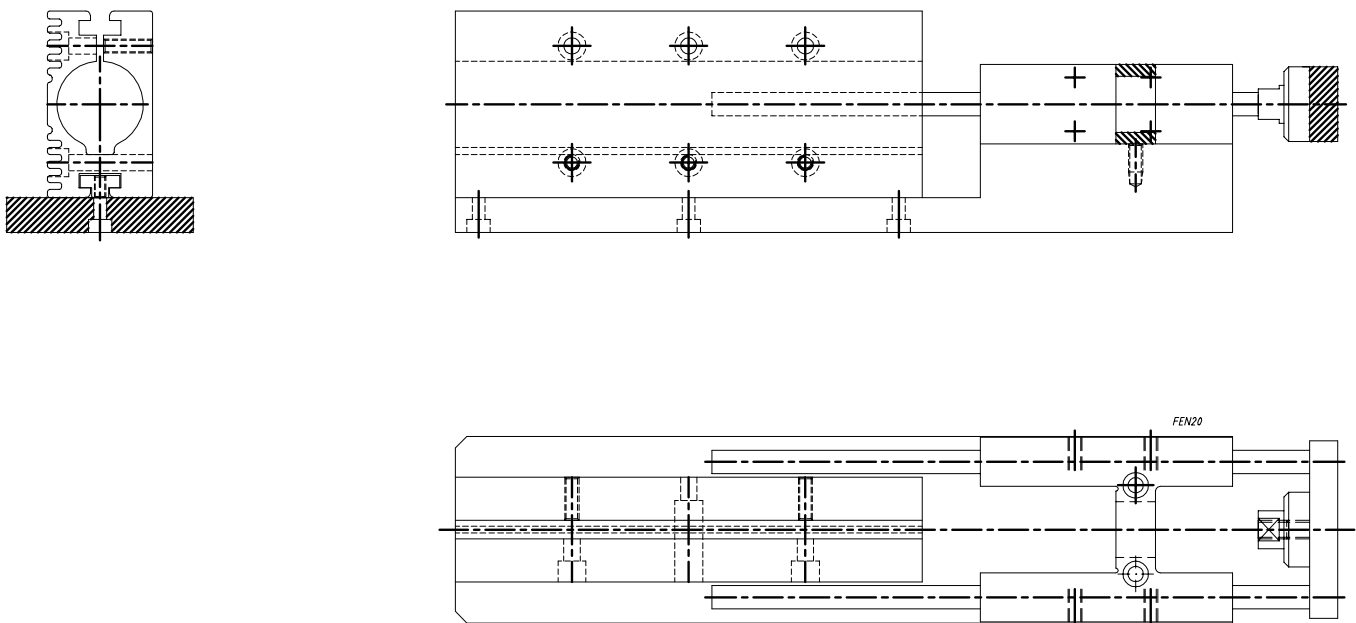

For the P03-37 motor type the FEN-20 guide unit of Festo may be used (see section on accessories). The through hole for the slider must be enlarged to 26 mm diameter. Otherwise the motor with a standard flange and the guide may be fixed in alignment on a basic unit.

### Design suggestion for H guiding

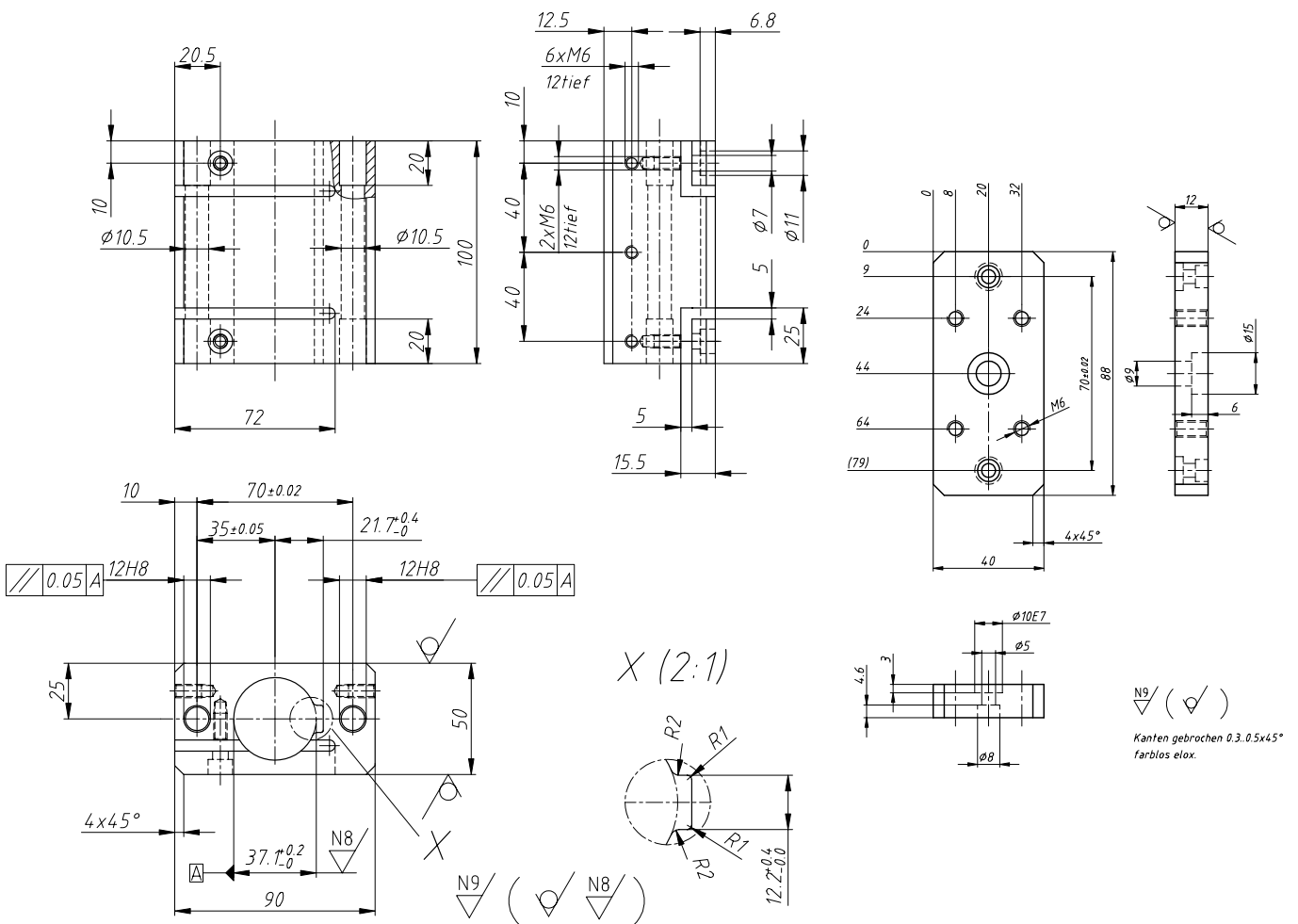

Maintenance of parallelism between motor hole and shafts is important, also the flatness of the front plate where the slider and the shafts are fixed. Steel shafts (W 10 h6 01 M4 350 VA) and plain bearing bushes are standard parts from INA (see page 51).

## Coupling to lever mechanisms

The following illustrations show three possibilities for transmitting the linear motion of a linear motor to a lever mechanism. In principle the design is the same as that employed with hydraulic or pneumatic cylinders. As with any servomotor application, adequate cooling must be assured. Especially where the motors are supported rotatably, a standard flange or comparable device must also be fitted to the motor, to ensure good heat emission.

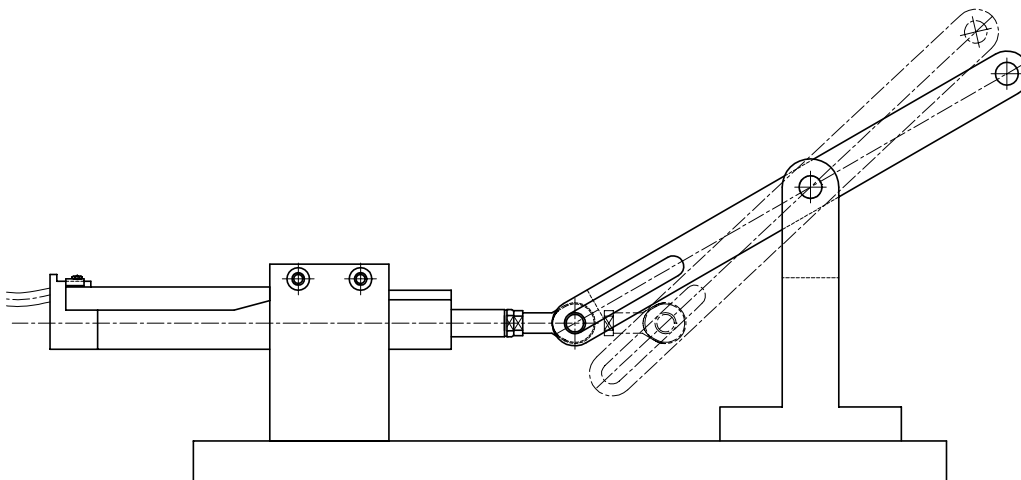
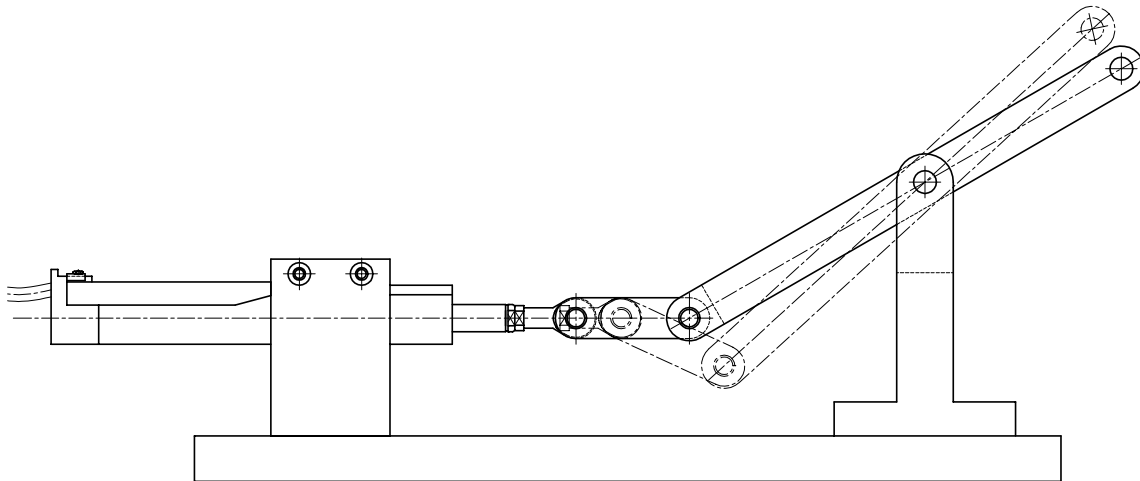
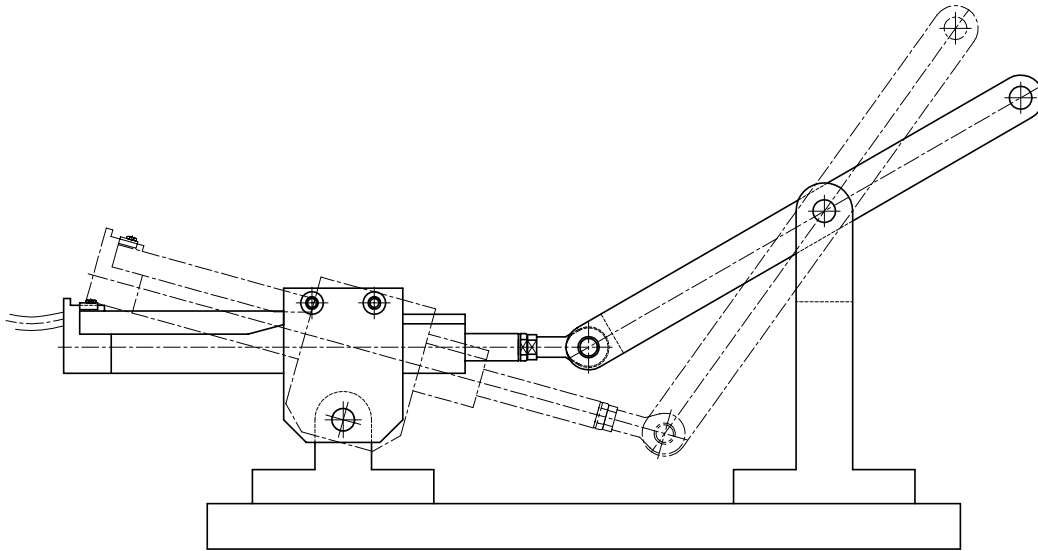

## Static forces

In application where the linear motor is mounted vertically, the motor has to produce a constant force to compensate the static force produced by gravity and the payload (mechanical construction, grippers, product mass, etc.). The static force may be compensated with mechanical components like springs or gas springs. After the compensation of the static force with one of these mechanical elements, the motor only has to produce a force during acceleration or deceleration (like in applications with horizontal mounting).

The three drawings show possible constructions for load compensation in applications with vertical mounting.

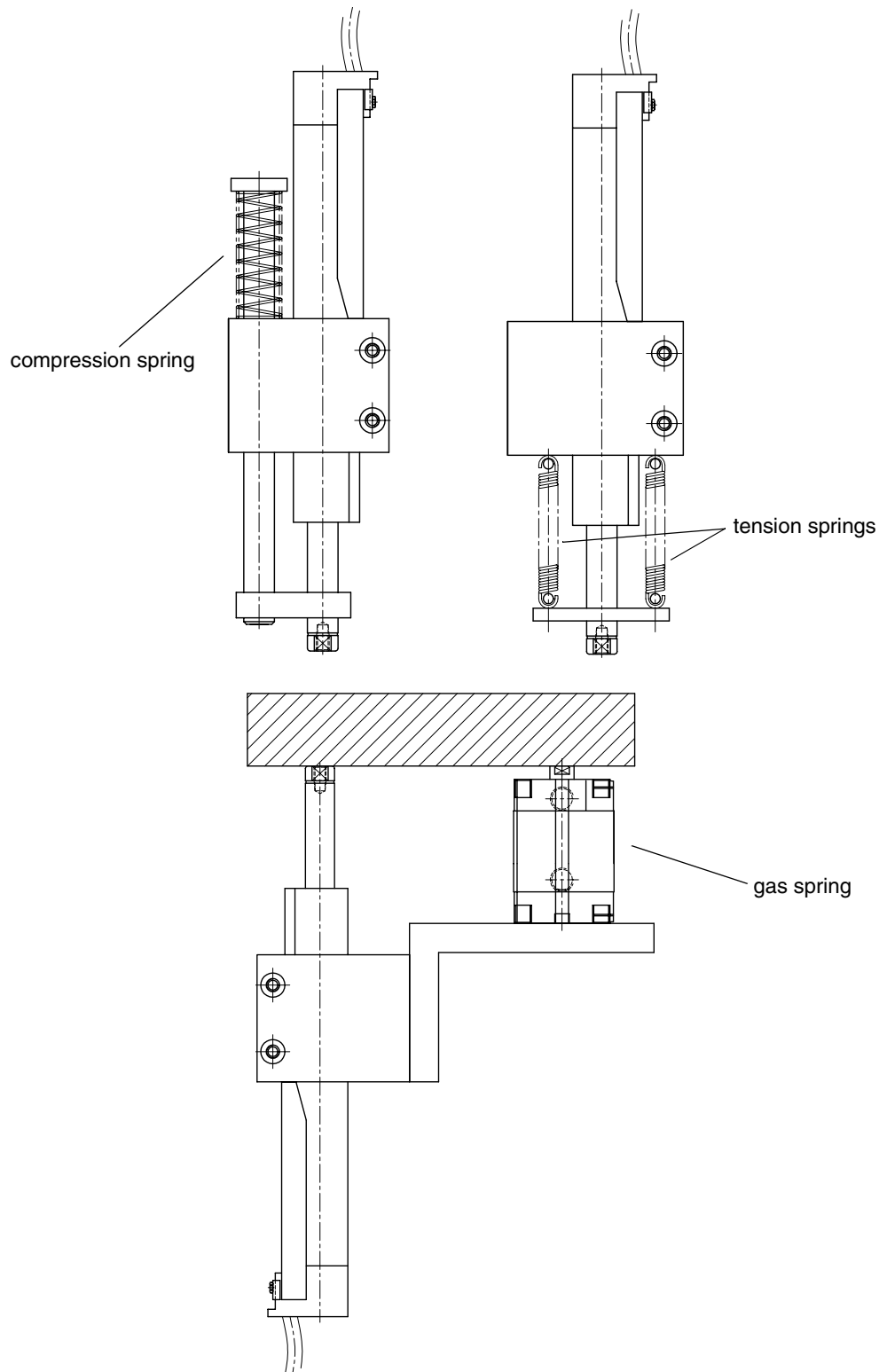

## Moving stator/stationary slider

Instead of the slider the stator too may be moved. This arrangement offers dynamic advantages mainly with motors of size P01-37 with longer strokes, as in such cases the stator mass is less than the slider mass. Important with this design is good supplementary guiding of the stator and the load mass fixed to it, also the use of a highly flexible cable in a trailing chain guide.

### Stator on roller guides

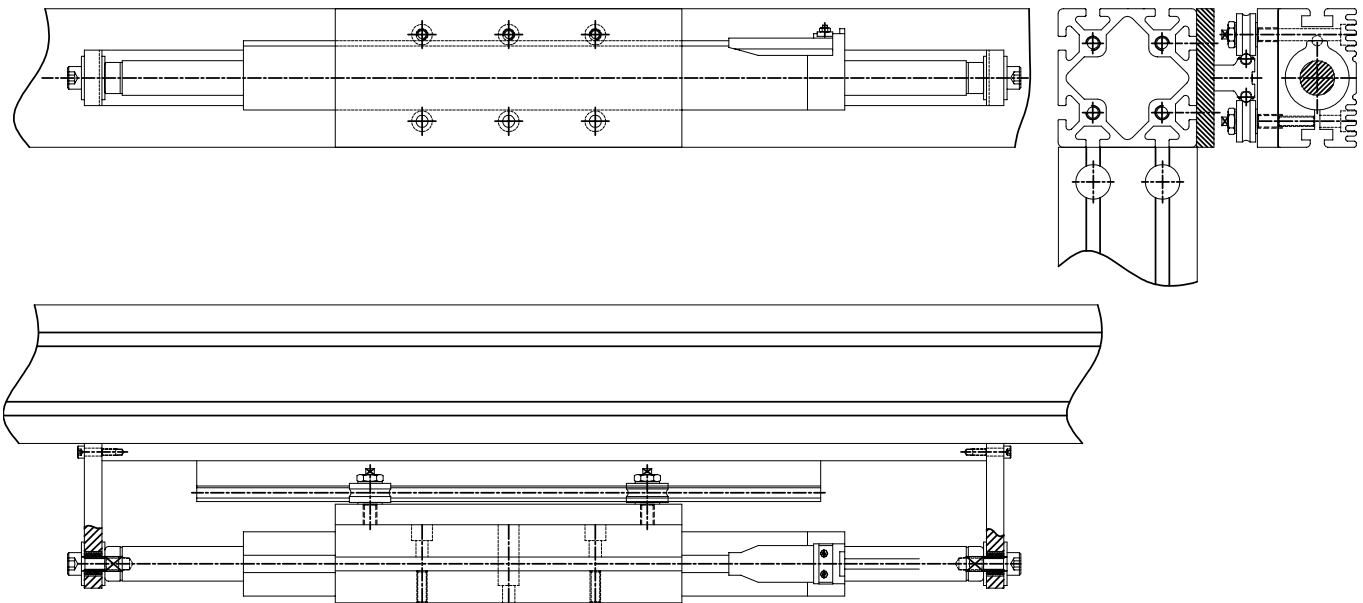

The slider is firmly held and the stator becomes the moving part. It may be screwed onto the carriage of an LFR roller guide from INA (see page 51) with a standard flange. Very important is the alignment of the stator motion axis to the slider, to rule out additional friction forces. To compensate the length tolerances and the thermal expansion of the slider, the latter may be fixed with disk springs for example.

### Cable led in trailing chain to moving stator

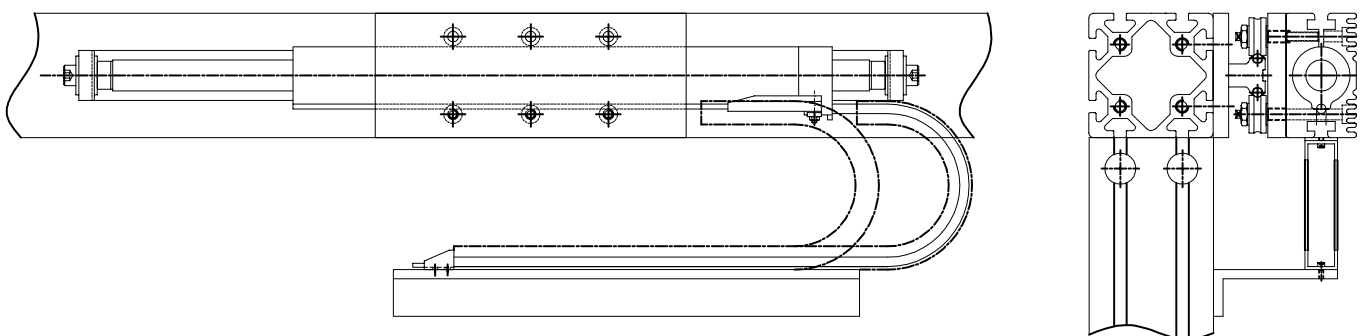

Special attention must be given to the cable lead with moving stators. Commercially available for such applications are highly flexible cables which, together with trailing chains, assure dependable connection. To enable a close bending radius to be negotiated it is advisable to use two separate cables. One cable carries the power with four 0.25 mm<sup>2</sup> conductors, while the other carries the signal lines with five 0.14 mm<sup>2</sup> conductors. Various cable types and their manufacturers are set out on page 54.



## Motor cooling

One of the factors limiting the performance of electric motors is the maximum power loss in the form of heat that can be rejected to the environment. Consequently special attention must always be given to the cooling of electric motors.

In the data sheets, 'continuous force' is indicated, meaning the force that can be attained with a linear motor installed using the appropriate standard flange. This force can be increased significantly by providing better cooling. With forced air cooling for example the heat emission can be doubled approximately compared with natural convection. A cooling circuit with liquid coolant will raise the heat emission up to 5 times the value with a simple installation using a standard flange.

### Forced air cooling

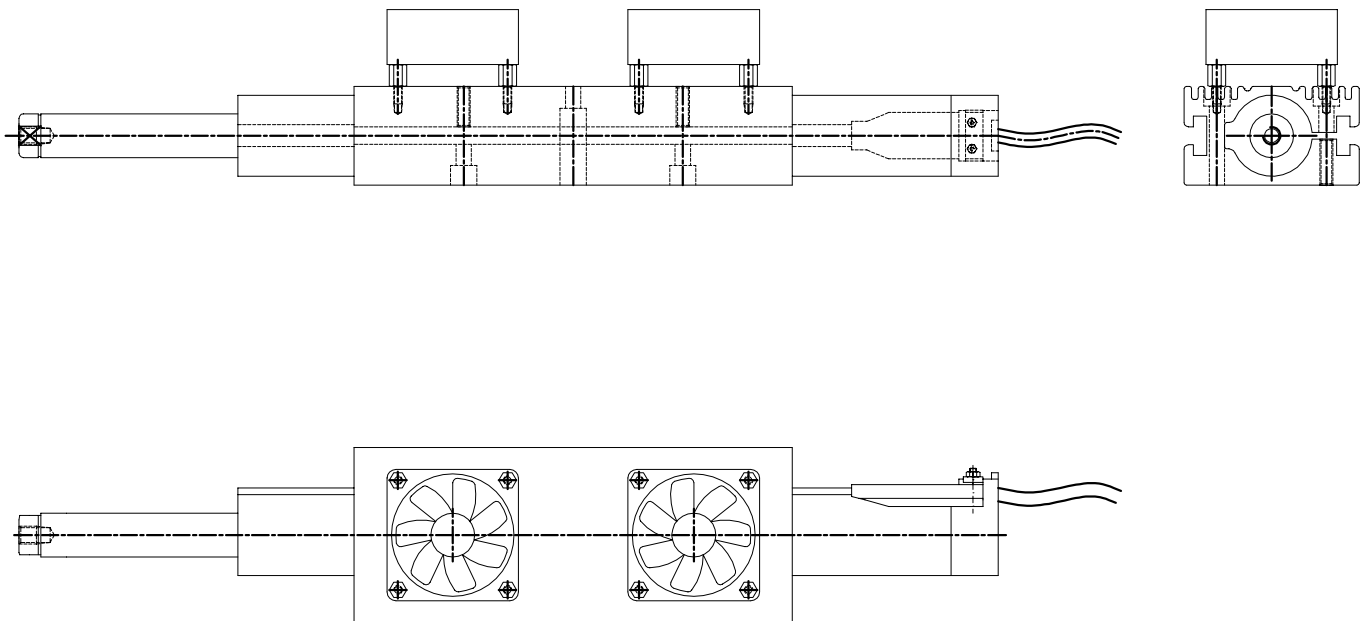

A simple way of providing forced air cooling is to fit one or two fans with distance bolts straight on the motor flange, as shown above. A very compact unit is the result.

## Applications

Shown in the section following are a few basic designs using LinMot, which may be employed in similar form in a variety of applications. From these sketches an experienced designer can easily find the best answer to his needs, adding his own ideas as appropriate.

### Compact XY unit

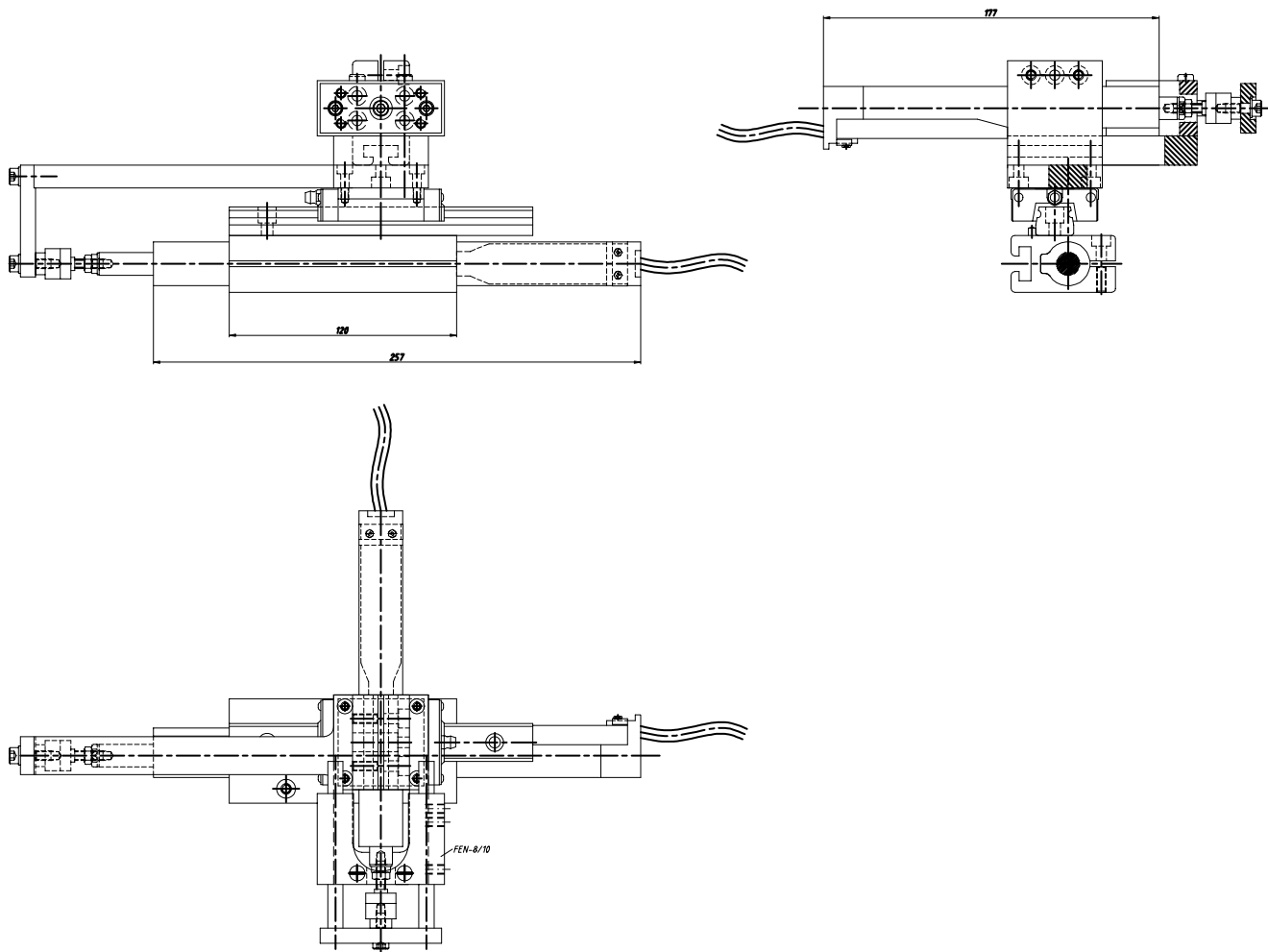

XZ unit assembled from two linear motors and two different guiding modes. The supplementary guiding of the X axis is provided by a recirculating ball unit mounted straight on the fixing flange. For the Z axis a guiding unit from pneumatics is employed, which at the same time acts as a safeguard against twisting and falling-out. The design shown here uses a P01-23x160 for the X axis and a P01-23x80 for the Z axis. Of course the same design could be executed with the bigger motors of the P01-37 series.

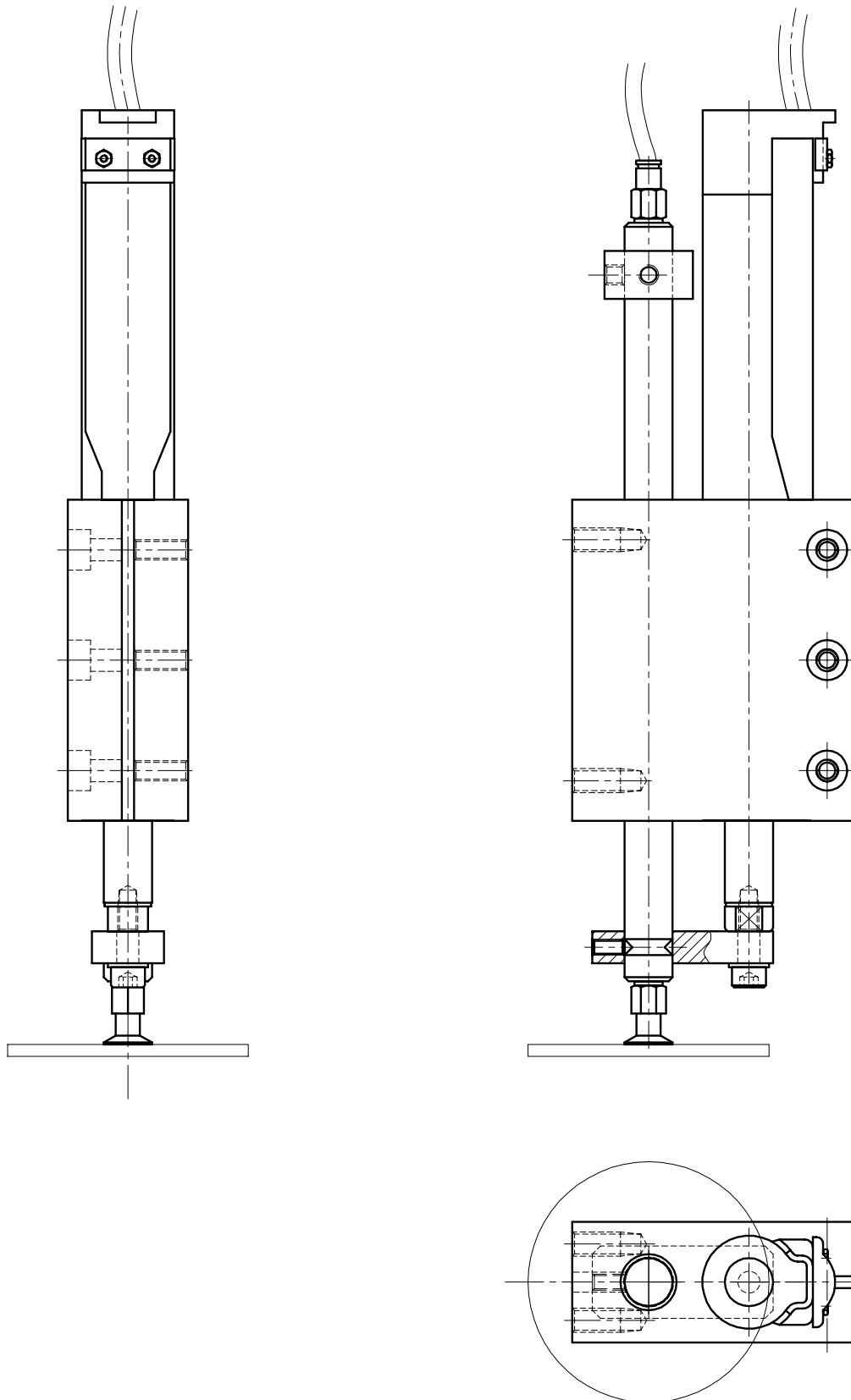
**Vacuum**

The air line runs in a tube (hollow shaft) parallel with the motor. The hollow shaft acts at the same time as a safeguard against twisting and falling-out. When making the fixing piece, be sure that the parallelism is maintained between the guiding and the motor mounting.

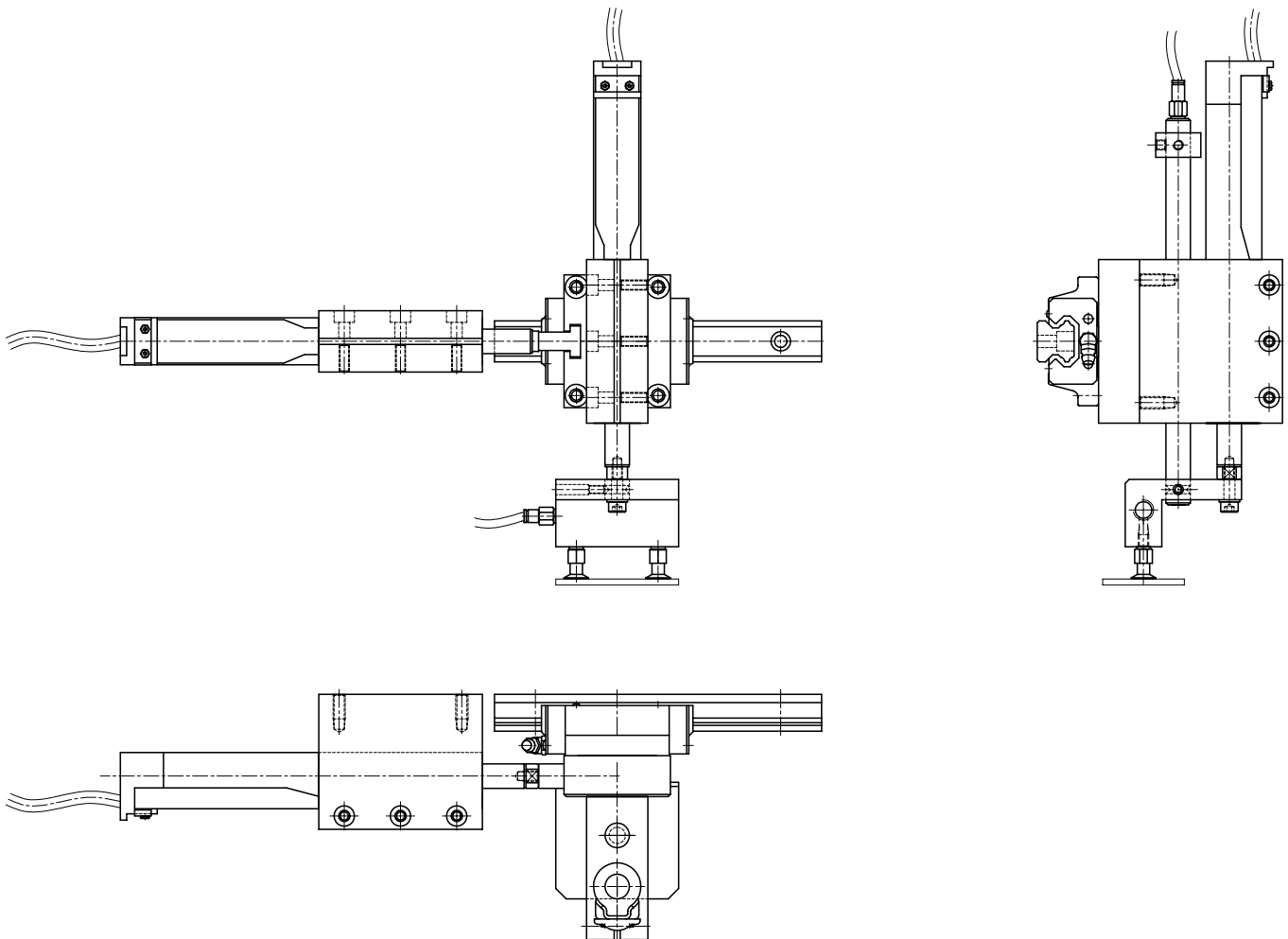
**Pick und place with vacuum**

This function unit is a combination of supplementary guide and moving vacuum. As shown above the supplementary guide is in the motor extension. The movement in the X direction is performed with it. Seated on it is the second axis, which performs the movement in the Z direction. This has as gripping element a plate with two suction connections. Unlike the previous design, the air hose is led straight from the suction element, and the vertical guiding shaft parallel with the slider of the motor acts only as a safeguard against twisting and falling-out.

## Feeler head assembly for measuring force

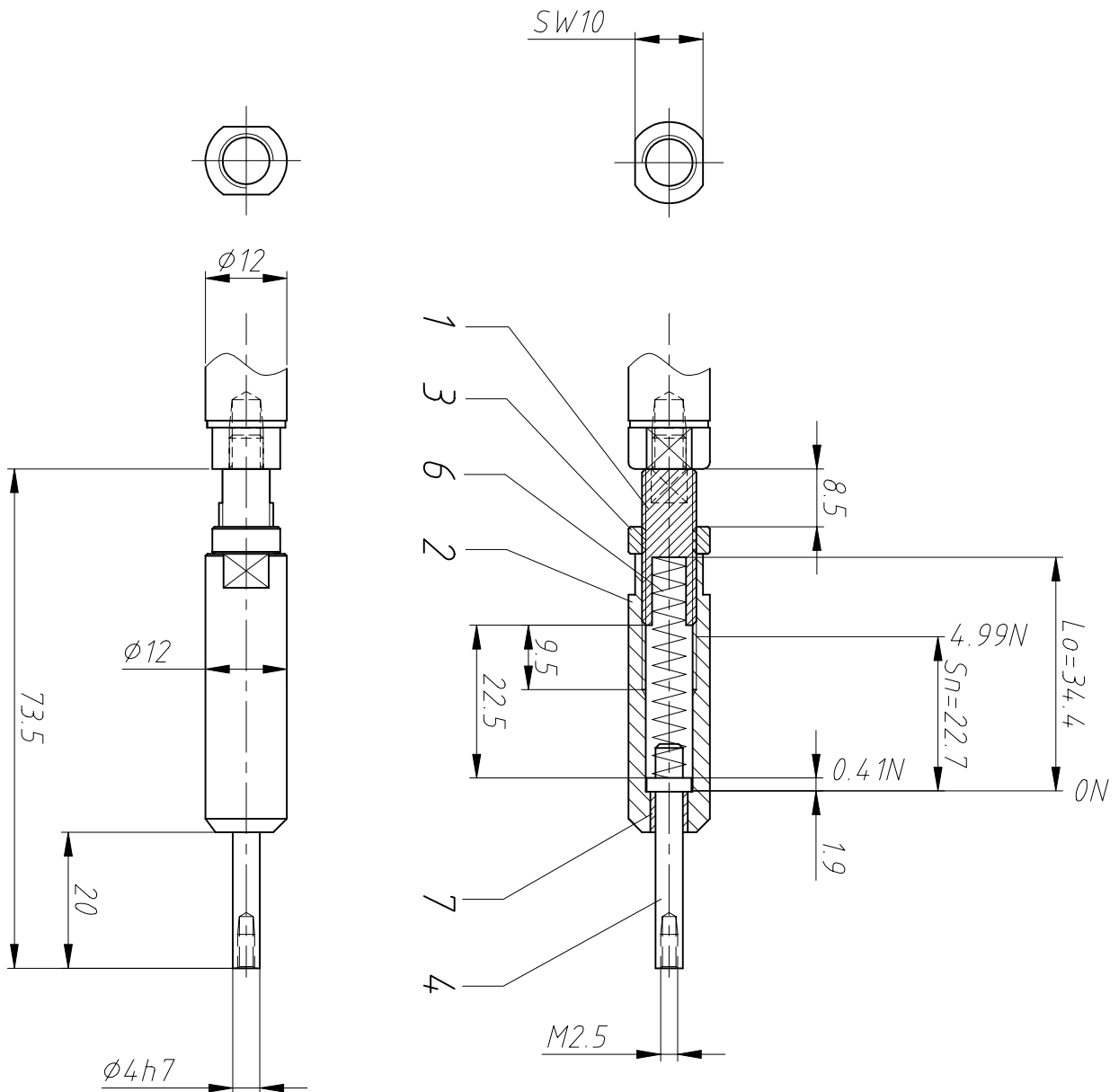

Exerting a defined force is a standard application for LinMot linear motors, whether parts have to be guided or pressed on, or pushbuttons have to be function-tested for example. The most straightforward method is to adjust the maximum force via current limitation in the software. However this solution is not very suitable for very small forces, because the force can be controlled only via the motor current and the motor friction for example is not taken into account. A more exact force adjustment can be obtained by assembling a feeler head as shown above. Here the positionability of the linear motors is used to compress a spring by a defined length. By virtue of the exact force-displacement diagram of the spring, even very small forces can be set with high accuracy by this method. Via the spring length the force can be adjusted with a thread. Any standard dial gauge stylus forms may be screwed onto the front.

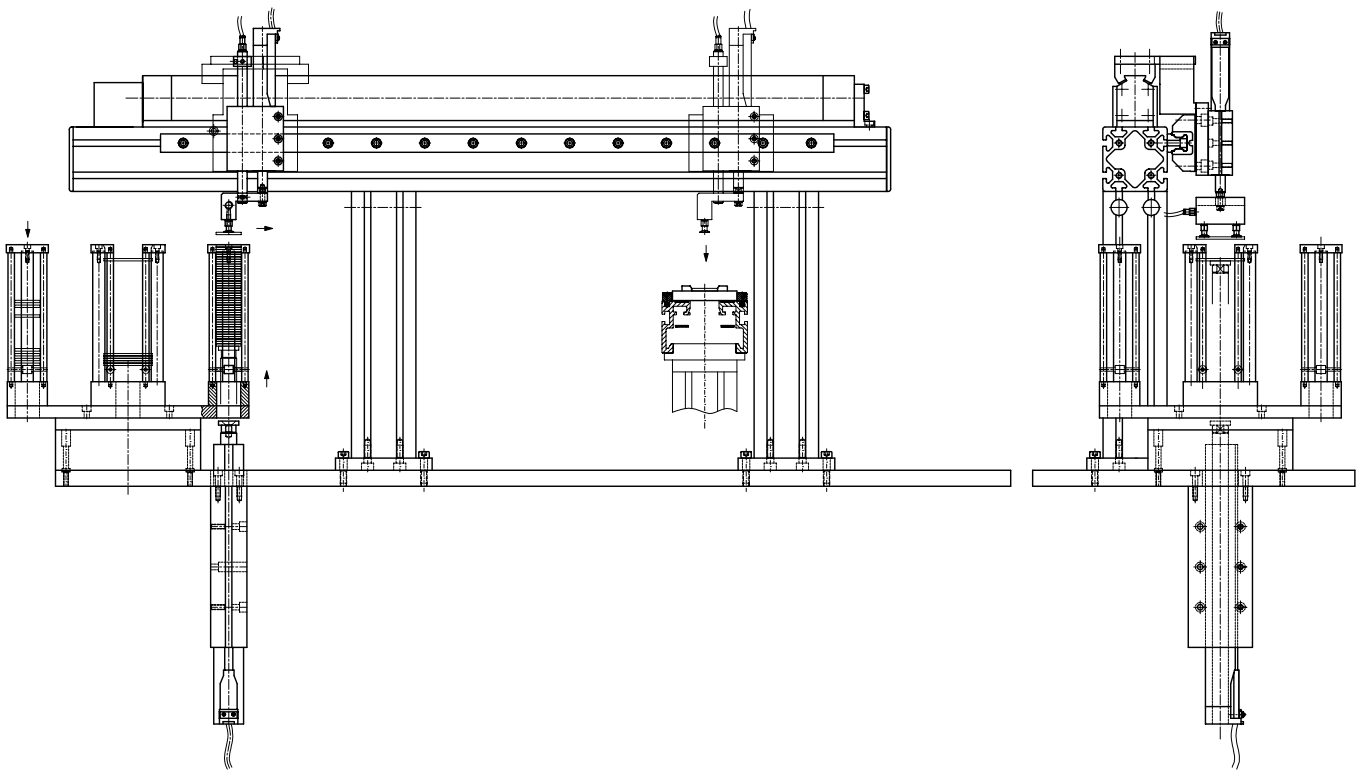
**Stacking and sorting**

Employed as gripping unit in the Z axis is the pick and place device with vacuum already presented. P01-23x80 motors have been selected as drive. For the bottom motors P01-37x240 types are used in this case, because there is a big permanent load mass (stack plus guidance).

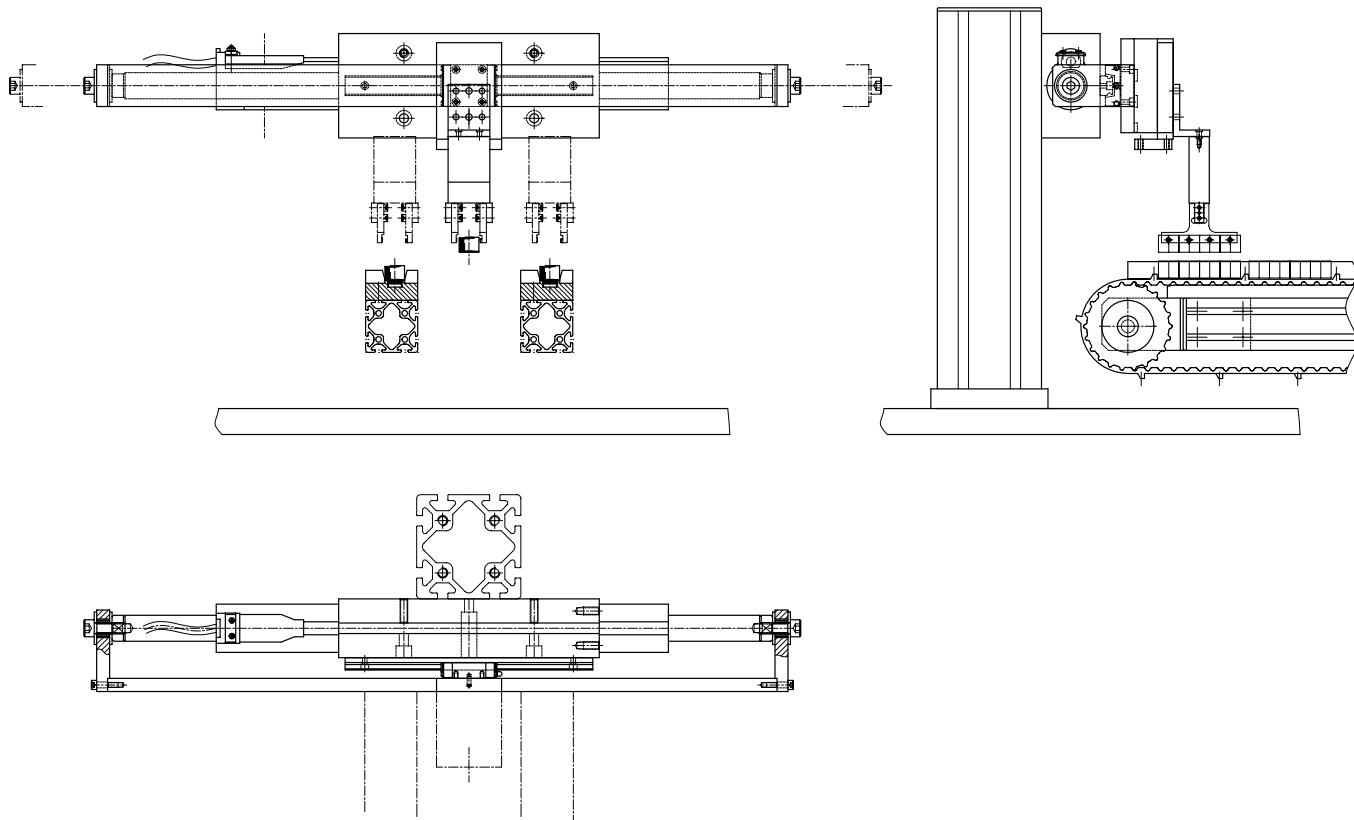
**Gripping moving parts at different places**

A gripper head must be displaced horizontally to various positions. For this a design was adopted having the guide rail of a recirculating ball unit mounted straight on the motor flange. If a longer stroke is needed, it is possible to lengthen the flange or extend the guide rail beyond the end of the flange.

## Accessories

### Coupling elements

#### Ball-and-socket heads

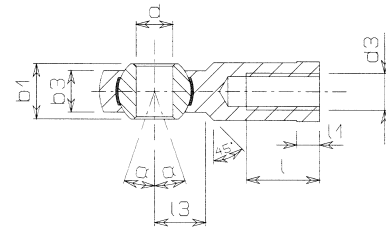
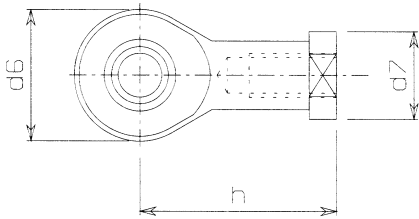

SMC Pneumatik GmbH    Boschring 13-15    D-63329 Egelsbach  
 Tel.: 06103/402-0    Fax: 06103/402-139    E-mail: info@smc-pneumatik.de    Homepage: www.smc-pneumatik.de

#### Clevises

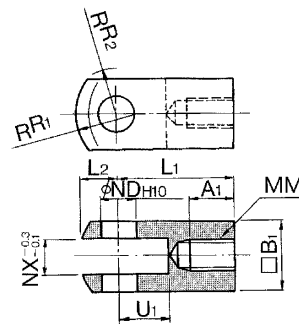
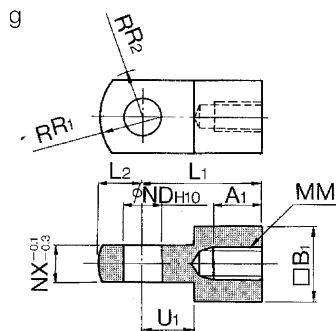

SMC Pneumatik GmbH    Boschring 13-15    D-63329 Egelsbach  
 Tel.: 06103/402-0    Fax: 06103/402-139    E-mail: info@smc-pneumatik.de    Homepage: www.smc-pneumatik.de

#### Ball-and-socket joints

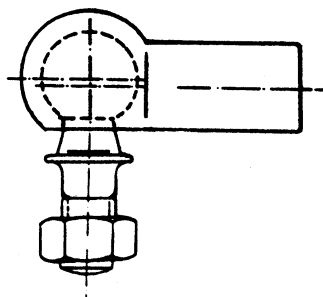

HPC Drives Ltd.    Foxwood Industrial Park    Chesterfield, Derbyshire S41 9RN England  
 Tel.: 01246/455500    Fax: 01246/455522    E-mail: sales@hpc-drives.com    Homepage: www.hpc-drives.com



### SMC compensators

For compensating axial and angular misalignment between linear motor and linear guiding.

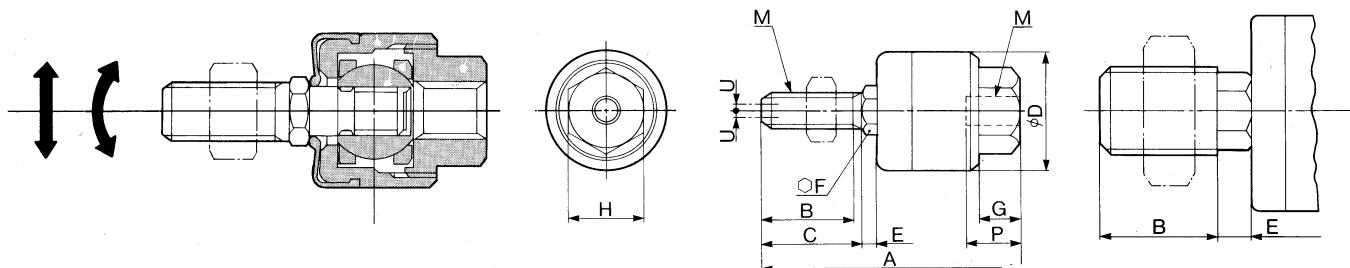

Model	M (Thread Ø)	A	D	Max. thread depth P	Permissible eccentricity U	Max. tensile and pressure load (N)
JA 15-5-080	5	34	16	8	0.5	
JA20-8-125	8	44	21	8	0.5	1100

SMC Pneumatik GmbH    Boschring 13-15    D-63329 Egelsbach  
 Tel.: 06103/402-0    Fax: 06103/402-139    E-mail: info@smc-pneumatik.de    Homepage: www.smc-pneumatik.de

### Flexo coupling from FESTO

For compensating axial and angular misalignment between linear motor and linear guiding.

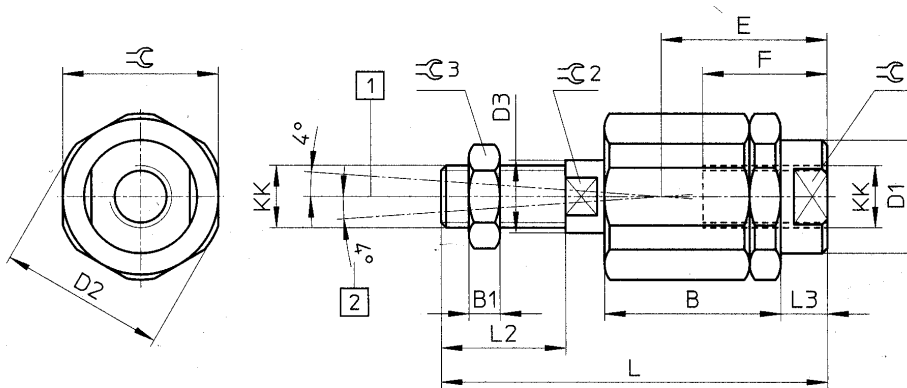

Model	D <sub>2</sub>	L	For piston rod thread KK	Material	Weight kg	Max. admissi- ble tension and pressure load N (≈ kp)	Radial deviation P (mm)
FK-M5	14.5	38.5	M5	Galvanized steel	0.020	1200 (120)	0.5
FK-M8	19	48.5	M8		0.050	2500 (250)	0.5

Festo AG & Co.    Ruiter Strasse 82    D-73734 Esslingen  
 Tel.: 0711/347-0    Fax: 0711/347-2144    E-mail: service\_deutschland@festo.de    Homepage: www.festo.de

## Linear recirculating ball guides

### SHS recirculating ball guides from THK

The SSR recirculating ball guides from THK are suited for high traversing speeds and accelerations by virtue of their special design.

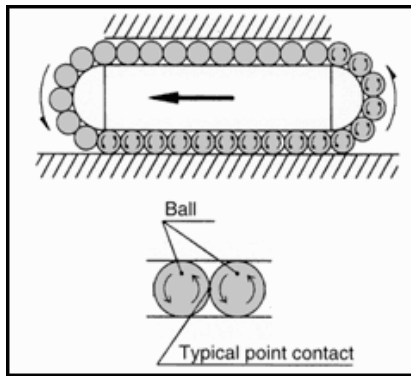

Conventional, Full Ball LM Guide

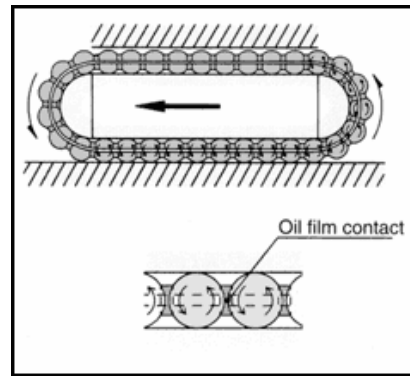

The THK Ball cage design

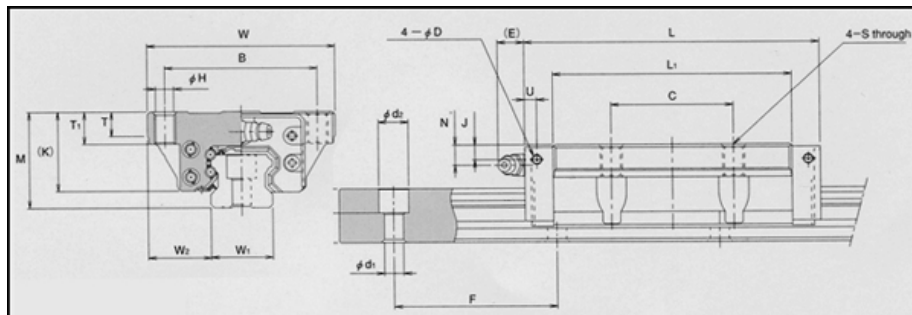

Model	Block & Assembly Data			Rail Data	Load Data	
	M	W	L	W1	C [KN]	Co [KN]
SHS15C	24	47	64.4	15	9.8	24.2
SHS20C	30	63	79	20	15.9	38.4
SHS20LC	30	63	98	20	20.9	50.3
SHS25C	36	70	92	23	22.1	52.4
SHS25LC	36	70	109	23	27.3	64.7

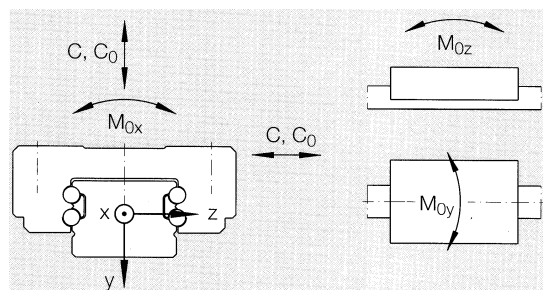

## INA roller guides

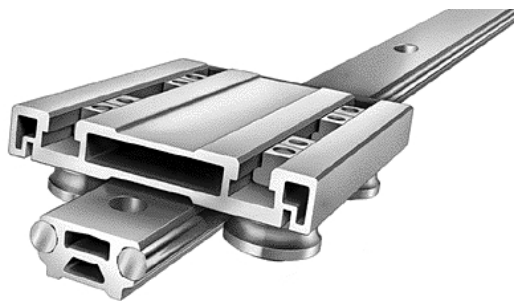

## INA miniature recirculating ball units KUME

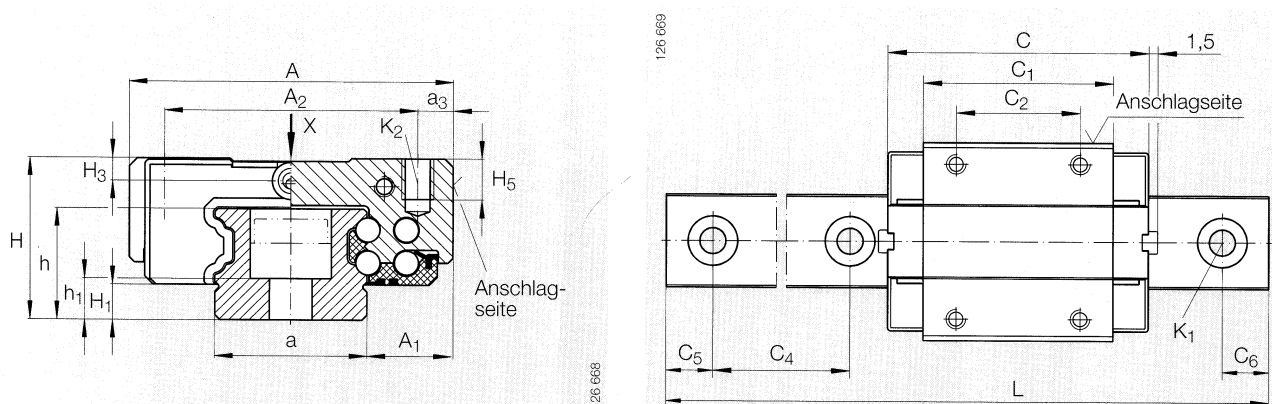

Model	Guide carriage	Dimensions			Fitting dimensions	Load capacity Force		Load capacity Moments		
	Weight (kg)	H	A	C	a -0.005 -0.050	C N	C <sub>0</sub> N	M <sub>0x</sub> Nm	M <sub>0y</sub> Nm	M <sub>0z</sub> Nm
KUME 9 B VA	0.03	10.0	20.0	31.6	15	1360	2700	16	9	9
KUME 12 B VA	0.056	13.0	27.0	36.6	20	2210	4000	30	15	15
KUME 15 B VA	0.06	16.0	32.0	42.0	23	3750	6800	65	33	33

## INA plain bearing bushes and shafts

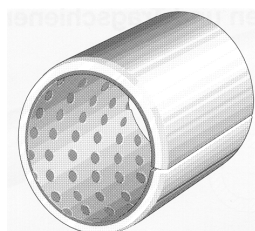

Permaglide™ bush P20

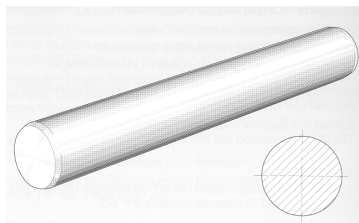

Shaft W

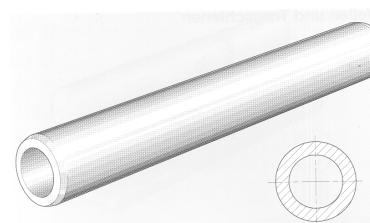

Shaft WH

## Linear guides with plain bearings



### FESTO guide units FEN-8/10-... for motors P01-23x...

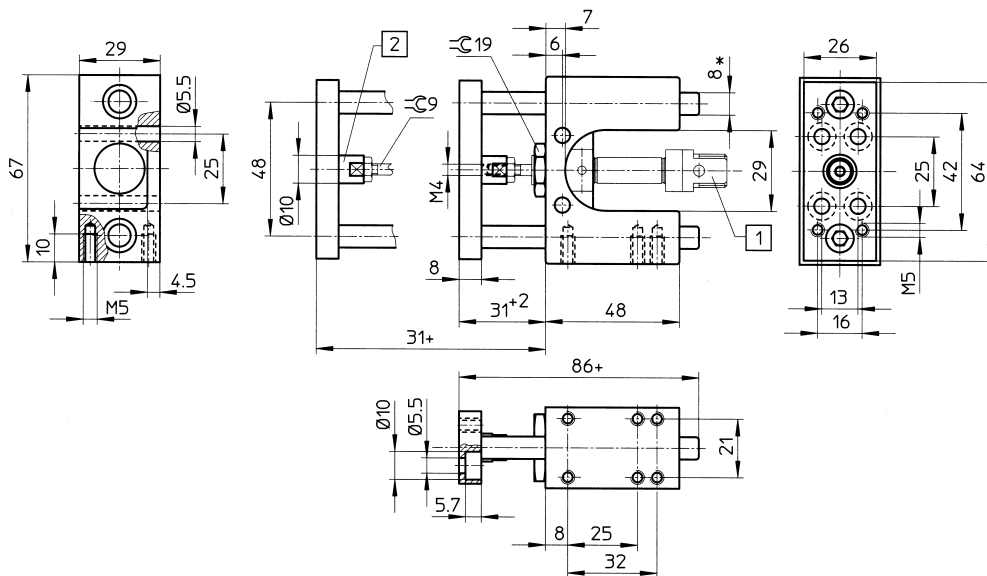

### FESTO guide units FEN-20-... for motors P01-37x...

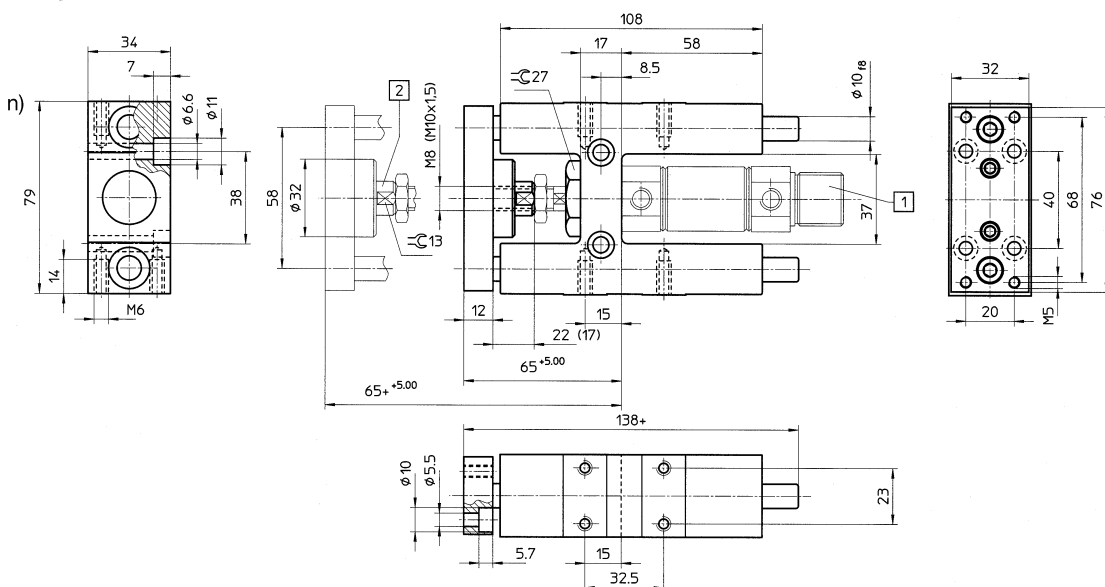

### IGUS DryLin® T - with clamping

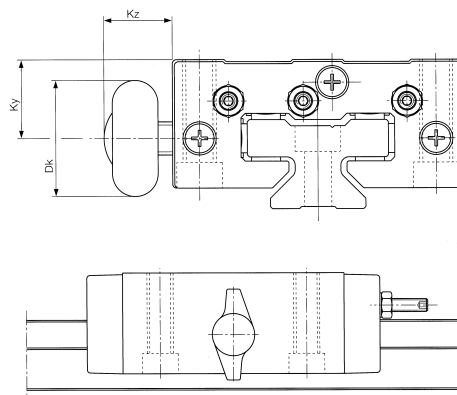
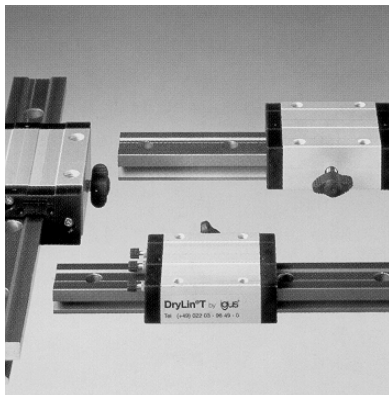

igus® GmbH    Spicher Strasse 1a    D-51147 Köln  
 Tel.: 02203/9649-0    Fax: 02203/9649-222    E-mail: info@igus.de    Homepage: www.igus.de

### IGUS DryLin N - miniature profile

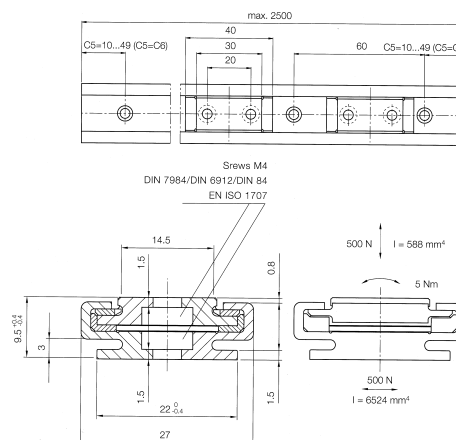
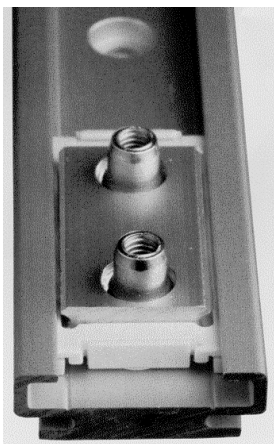

igus® GmbH    Spicher Strasse 1a    D-51147 Köln  
 Tel.: 02203/9649-0    Fax: 02203/9649-222    E-mail: info@igus.de    Homepage: www.igus.de

### Plain bearings

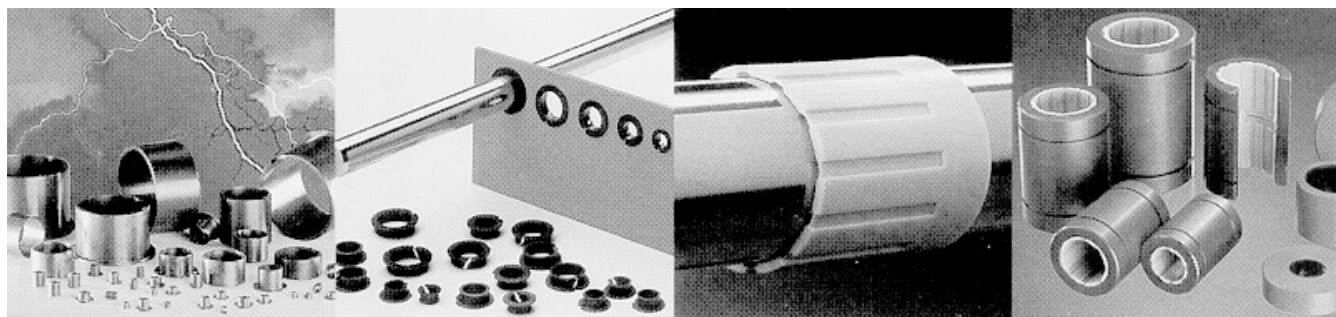

igus® GmbH    Spicher Strasse 1a    D-51147 Köln  
 Tel.: 02203/9649-0    Fax: 02203/9649-222    E-mail: info@igus.de    Homepage: www.igus.de

## Trailing chains

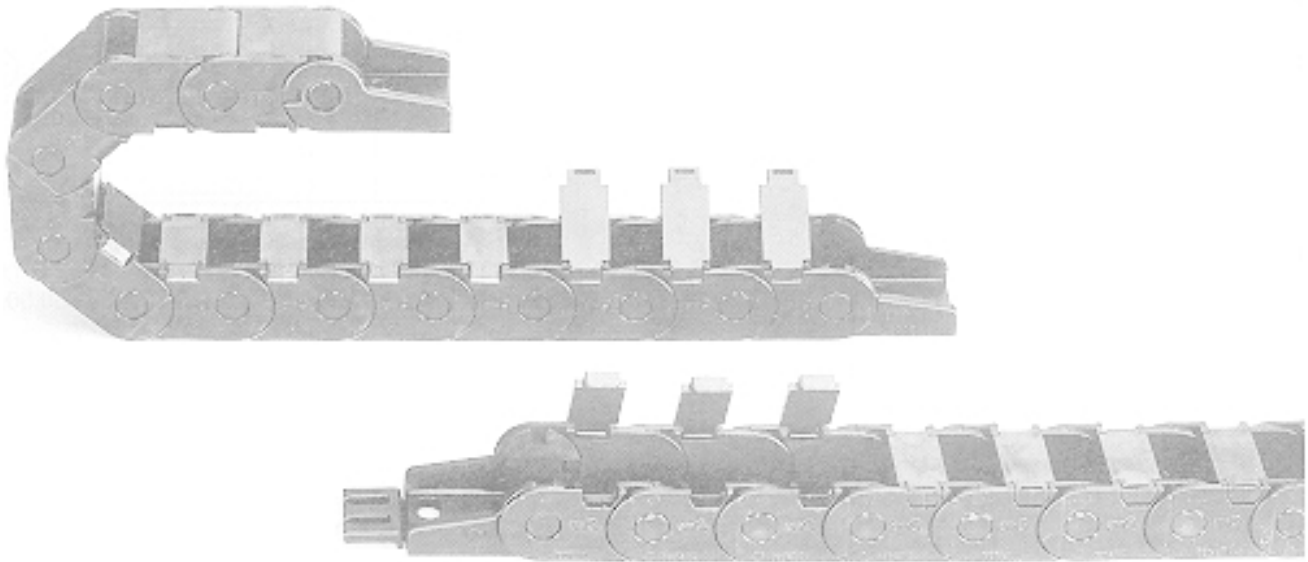

igus® GmbH    Spicher Strasse 1a    D-51147 Köln  
 Tel.: 02203/9649-0    Fax: 02203/9649-222    E-mail: info@igus.de    Homepage: www.igus.de

KabelSchlepp GmbH    Marienborner Strasse 75    D-57074 Siegen  
 Tel.: 0271/58 01-0    Fax: 0271/58 01-220    Homepage: www.hoppenstedt.de/kabelschlepp

## Trailing chain cable

**UNITRONIC-FD CY (sheathing: PVC) / UNITRONIC-FD CP (sheathing: PUR)**

Volland    Ifangstrasse 103    CH-8153 Rümlang  
 Tel.: 01/817 23 87    Fax: 01/817 23 87

**ACO ULTRAFLEX CY-DATA (sheathing: PUR)**

Basix AG    Hardturmstrasse 181    CH-8010 Zürich  
 Tel.: 01/276 11 11    Fax: 01/276 12 34

**IGUS CHAINFLEX CF2 (sheathing: PUR)**

igus® GmbH    Spicher Strasse 1a    D-51147 Köln  
 Tel.: 02203/9649-0    Fax: 02203/9649-222    E-mail: info@igus.de    Homepage: www.igus.de

## Lubricants

Application	Designation	Supplier	Description
Plain bearings	LinMot®	LinMot®	Plain bearing paste with solid lubricant constituents, suitable for plain bearings in all LinMot® applications with long-time lubrication.
	Molykote DX	Molykote	Alternative to LinMot® grease
Plain bearings / food industrie	Klybersynth UH1 14-31	Klüber Lubrication	USDA H1 approval. Synthetic low-temperature high-speed grease for rolling-contact and plain bearings, chains and seals.
Rolling-contact bearings	Microlube GBU Y 131	Klüber Lubrication	For rolling-contact and plain bearings, preferentially for high specific loads and influence of moisture and water.
Vacuum	Barrierta L55	Klüber Lubrication	High-temperature grease for rollers and ball bearings in conveying equipment and automatic baking ovens, also rolling-contact and plain bearings in electric motors.

Klüber Lubrication München KG Geisenhausenerstr. 7 D-81379 München  
 Tel.: 089/7876-0 Fax: 089/7876-333

## Bellows

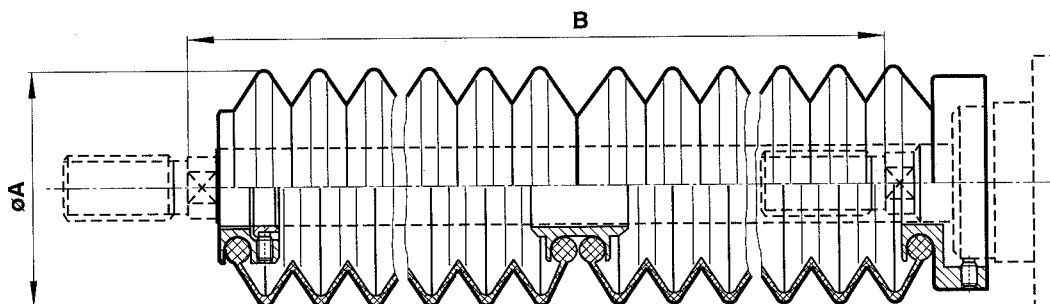

IMI Norgren Ltd. P.O. Box 22, Eastern Avenue Lichfield Staffordshire WS13 6SB United Kingdom  
 Tel.: 1543 414 333 Fax: 1543 268 052 E-mail: enquiry@norgren.com Homepage: www.norgren.com

Fipa GmbH Freisinger Strasse 32 D-85737 Ismaning bei München  
 Tel.: 089/96 24 89-0 Fax: 089/96 24 89-11 E-mail: info@fipa-online.com Homepage: www.fipa-online.com

## Load compensation for vertical movements

### Compression springs

Linear force increase with spring compression.

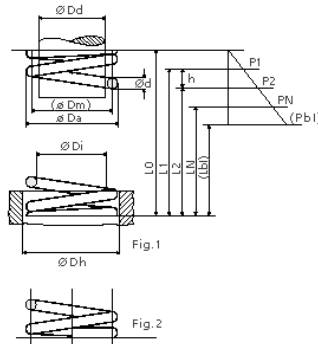

Favre-Stuedler SA Propsteiweg 7 CH-2504 Biel-Bienne  
 Tel.: 032/341 30 79 Fax: 032/342 52 34 E-mail: pfavre@favre-stuedler.ch Homepage: www.favre-stuedler.ch

### Tension springs

Linear force increase with spring extended.

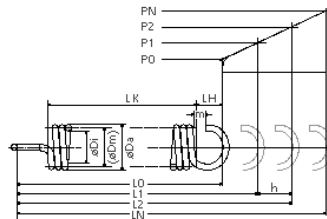

Favre-Stuedler SA Propsteiweg 7 CH-2504 Biel-Bienne  
 Tel.: 032/341 30 79 Fax: 032/342 52 34 E-mail: pfavre@favre-stuedler.ch Homepage: www.favre-stuedler.ch

### Gas springs

Gas springs feature almost constant force throughout the stroke range and allow simple load compensation with vertical movements.

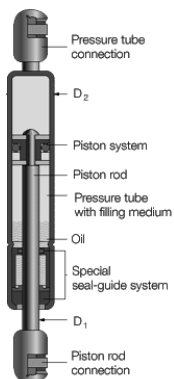

Characteristic curve of a gas spring

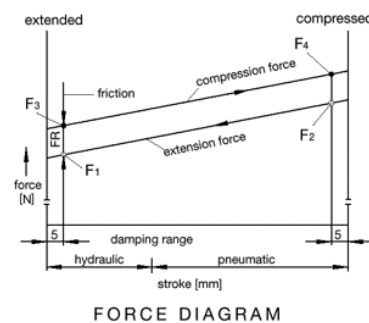

Stabilus GmbH Wallersheimer Weg 100 D-56070 Koblenz  
 Tel.: 0261/8900-230 Fax: 0261/8900-204 E-mail: info@de.stabilus.com Homepage: www.stabilus.com



## Clamping elements

Clamping elements for holding the load when motors cut out during vertical and horizontal movements (emergency stop, power failure etc.).

### Pneumatically opening circular guide clamping (MKR)

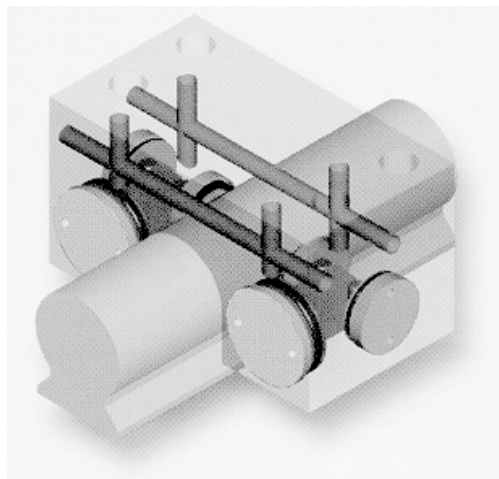

ZIMMER GmbH Technische Werkstätten Im Salmenkopf 5 D-77866 Rheinau-Freistett  
Tel.: 07844/9138-0 Fax: 07844/9137-80 E-mail: [zimmer-gmbh@t-online.de](mailto:zimmer-gmbh@t-online.de) Homepage: [www.zimmer-gmbh.de](http://www.zimmer-gmbh.de)

### Electromechanical clamping

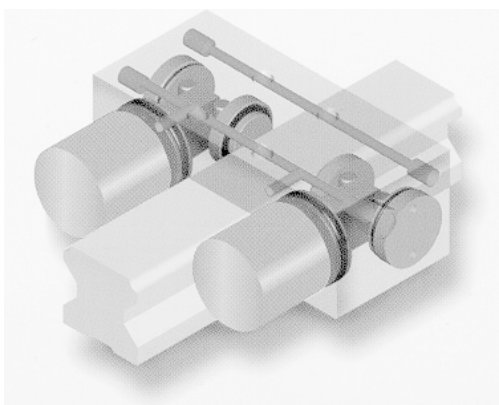

ZIMMER GmbH Technische Werkstätten Im Salmenkopf 5 D-77866 Rheinau-Freistett  
Tel.: 07844/9138-0 Fax: 07844/9137-80 E-mail: [zimmer-gmbh@t-online.de](mailto:zimmer-gmbh@t-online.de) Homepage: [www.zimmer-gmbh.de](http://www.zimmer-gmbh.de)

## Stepper motors

Besides the linear drives of the LinMot P series, two-phase stepper motors can be controlled by the LinMot E electronics units.

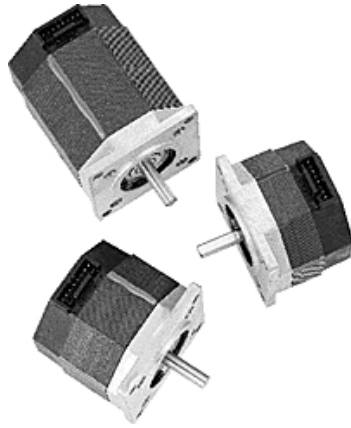

Pacific Scientific 4301 Kishwaukee Street Rockford, Illinois 61109 USA  
Tel.: 815/226 31 00 Fax: 815/226 30 80 E-mail: customer\_service@atg.pacsci.com Homepage: www.pacsci.com

## Electrical grippers

### Grip PE 410

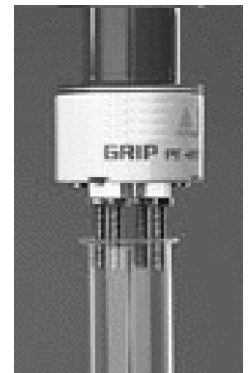
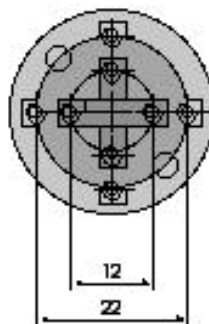
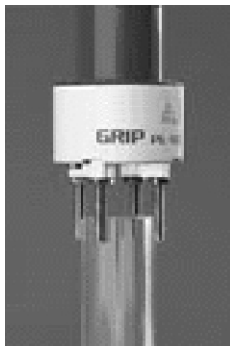

LinMot - Sulzer Electronics AG Technoparkstrasse 1 CH-8005 Zürich  
Tel.: 01/445 22 82 Fax: 01/445 22 81 E-mail: office@linmot.com Homepage: www.linmot.com

# Mechanical dimensions of LinMot® products

## Analog and Multitrigger electronics units

**E100-AT / E200-AT / E400-AT**  
**E100-MT / E200-MT / E400-MT**

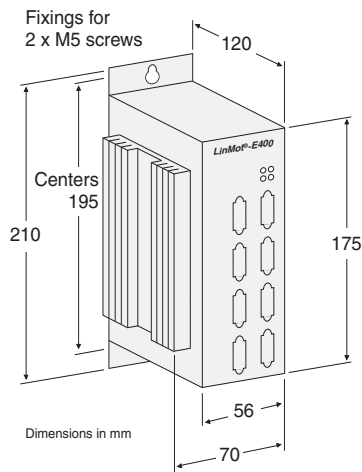

**E1000-AT / E2000-AT / E4000-AT**  
**E1000-MT / E2000-MT / E4000-MT**

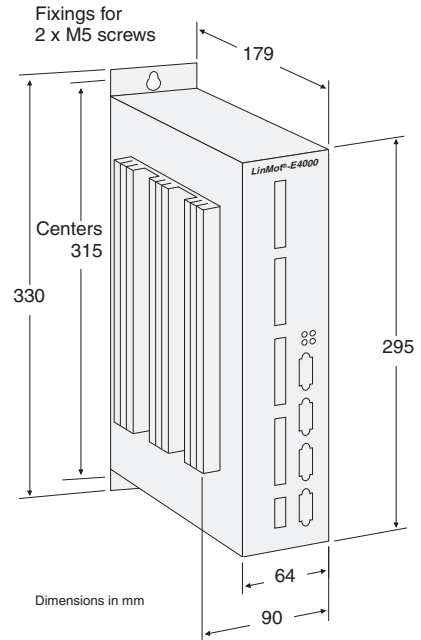

## PROFIBUS-DP electronics units

**E130-DP / E230-DP / E430-DP**

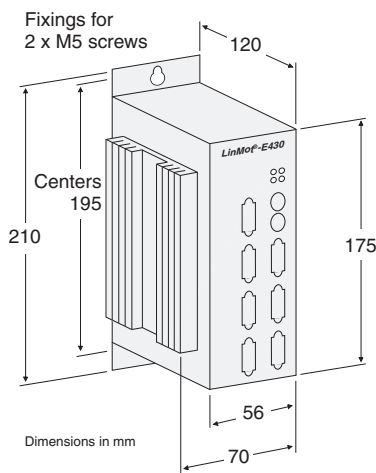

**E1030-DP / E2030-DP / E4030-DP**

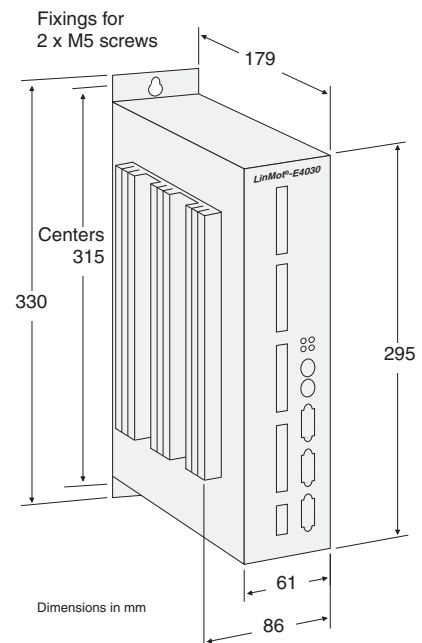

## Linear motors family P01-23x80

The four linear motors of the P01-23x80 family feature a particularly compact design, allowing installation even in limited space conditions. The electronics units of the 100 series are used to control the P01-23x80 linear motors.

### Principal data:

Max. stroke range:	210mm
Max. force:	33N
Max. acceleration:	280m/s <sup>2</sup>
Max. speed:	2.4m/s

### Dimensions:

Stator length:	177mm
Stator diameter:	23mm
Stator mass:	265g
Slider diameter:	12mm

### Connections:

Cable:	9-pin (4+5)
Cable length:	1m
Connector:	9 pins D-sub (m)

### Temperature:

Max. stator temperature:	65°C
--------------------------	------



### Physical dimensions

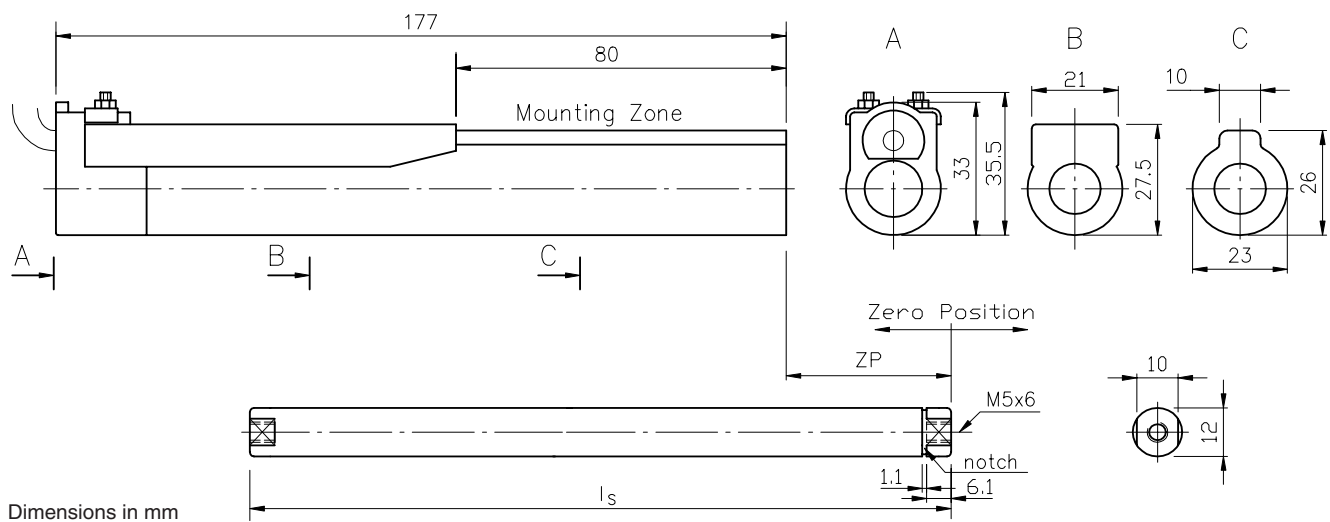

## Linear motors family P01-23x160

The six linear motors of the P01-23x160 family differ from those of the P01-23x80 family with their somewhat greater length and hence higher maximum force. The electronics units of the 10 and 1000 series can be used to control the linear motors P01-23x160.

1

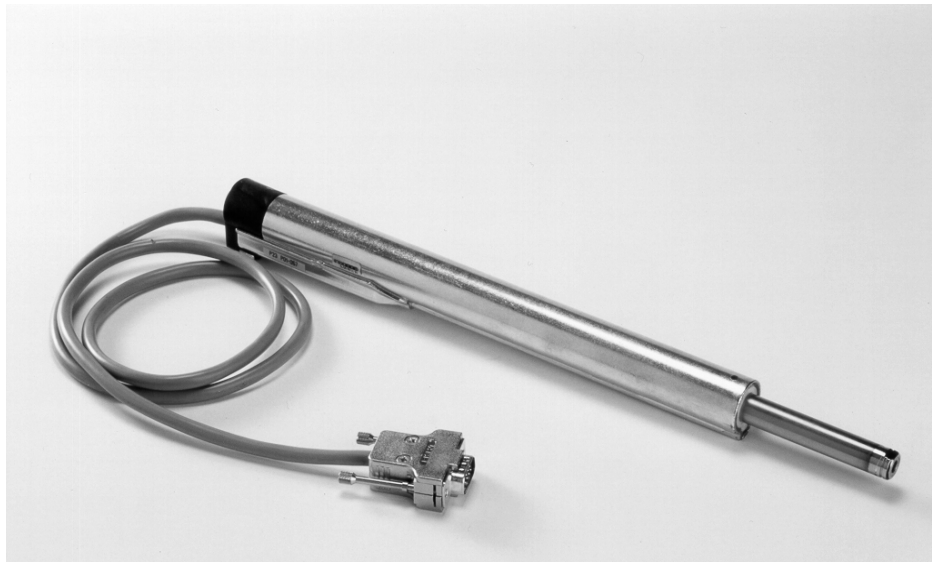

### Principal data:

Max. stroke range:	340mm
Max. force:	60N
Max. acceleration:	350m/s <sup>2</sup>
Max. speed:	4.2m/s

### Dimensions:

Stator length:	257mm
Stator diameter:	23mm
Stator mass:	450g
Slider diameter:	12mm

### Connections:

Cable:	9-pin (4+5)
Cable length:	1m
Connector:	9 pins D-sub (m)

### Temperature:

Max. stator temperature:	65°C
--------------------------	------

### Physical dimensions

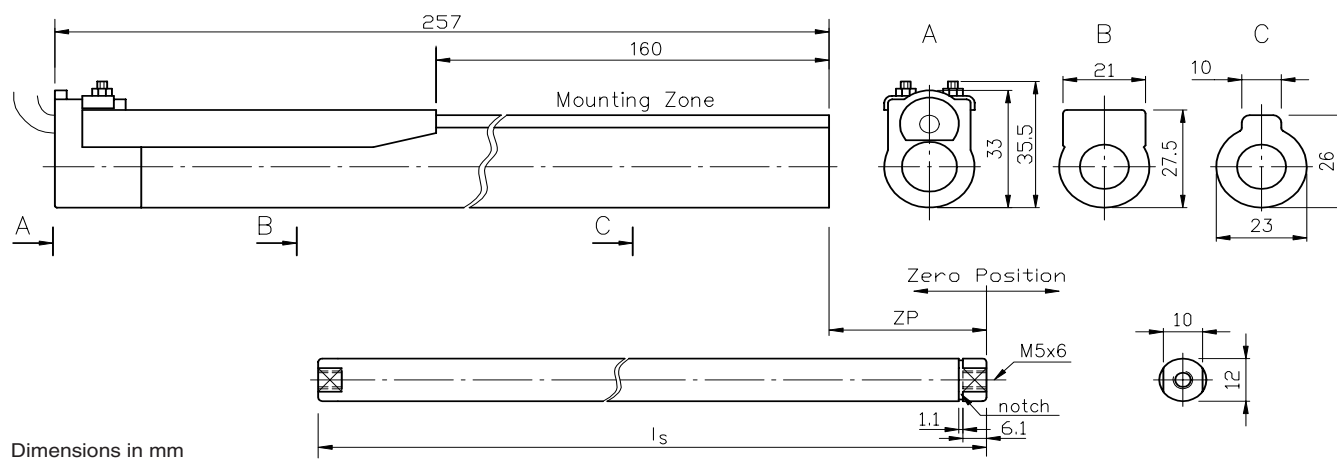

## Linear motors family P01-37x120

The twelve linear motors of the P01-37-120 family enable long-stroke motions to be performed with medium force. The electronics units of the 100 and 1000 series may be used to control the the linear motors P01-37x120

### Principal data:

Max. stroke range:	1400mm
Max. force:	122N
Max. acceleration:	247m/s <sup>2</sup>
Max. speed:	4.0m/s

### Dimensions:

Stator length:	227mm
Stator diameter:	37mm
Stator mass:	740g
Slider diameter:	20mm

### Connections:

Cable:	9-pin (4+5)
Cable length:	1.5m
Connector:	10 pins Mini Combicon

### Temperature:

Max. stator temperature:	65°C
--------------------------	------



### Physical dimensions

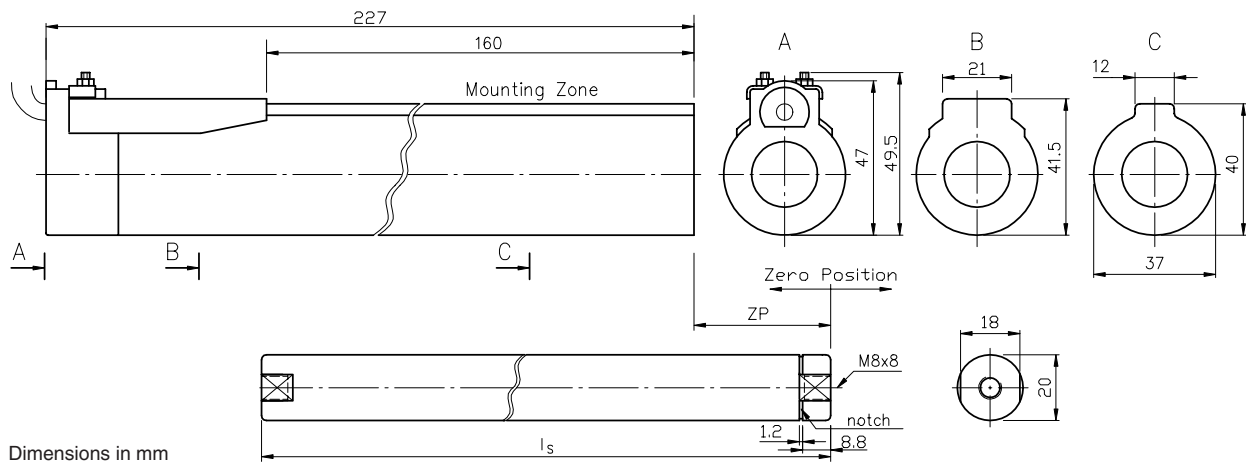

### Linear motors family P01-37x240

With the P0-37x240 family the biggest forces can be applied and the longest strokes performed. The electronics motors of the 100 and 1000 series can be used to control the linear motors P01-37x240.



#### Principal data:

Max. stroke range:	1460mm
Max. force:	204N
Max. acceleration:	268m/s <sup>2</sup>
Max. speed:	3.1m/s

#### Dimensions:

Stator length:	347mm
Stator diameter:	37mm
Stator mass:	1385g
Slider diameter:	20mm

#### Connections:

Cable:	9-pin (4+5)
Cabel length:	1,5m
Connector:	10 pins Mini Combicon

#### Temperature:

Max. stator temperature:	65°C
--------------------------	------

#### Physical dimensions

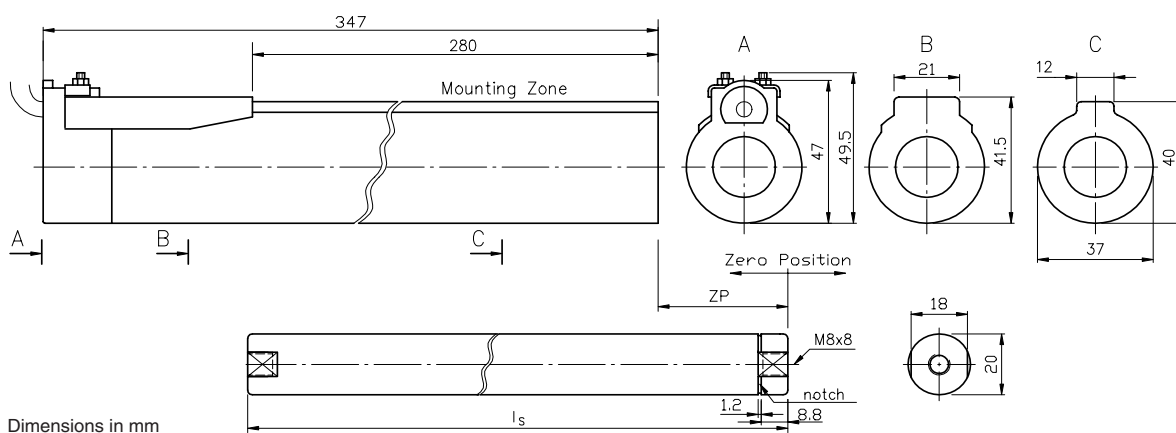

### PF01 flange

The PF01 flanges allow simple installation of the LinMot(R) P linear motors. Using these flanges assures the best mechanical stability and the best thermal conductivity. They may be either screwed straight onto a support or mounted with their T slot. Longer flanges give better cooling of the linear motors. The clamp plate design allows speedy and simple changing of linear motors without dismantling the flange.

#### PHYSICAL DIMENSIONS PF01-23x...

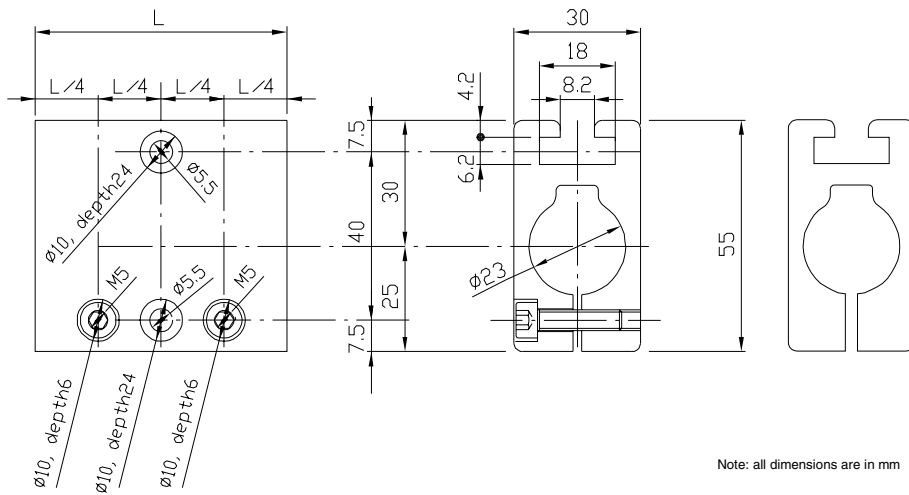

Max. torque for clamp plate screws: 200 Ncm

Clamp plate screws M5x16

Note: all dimensions are in mm

#### PHYSICAL DIMENSIONS PF01-37x...

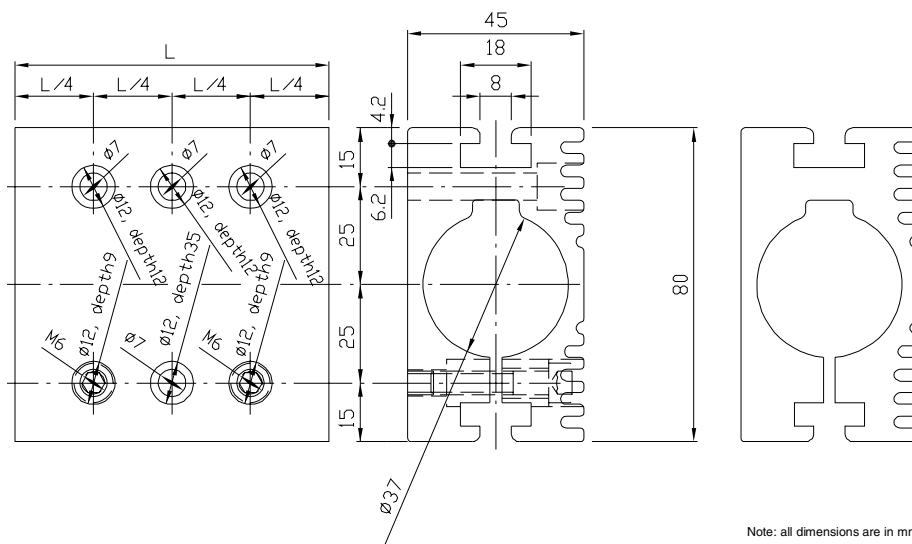

Max. torque for clamp plate screws: 200 Ncm

Clamp plate screws M5x16

Note: all dimensions are in mm



## Conversion tables and units

### Mass

<i>1g --&gt; 0.001kg</i>	<b>kg</b>	<b>g</b>	<b>oz</b>	<b>lb</b>
<b>kg</b>	1	0.001	0.02835	0.454
<b>g</b>	1000	1	28.35	454
<b>oz</b>	35.27	0.03527	1	16
<b>lb</b>	2.205	0.00205	0.0625	1

### Length

<i>1mm --&gt; 0.001m</i>	<b>m</b>	<b>mm</b>	<b>in</b>	<b>ft</b>
<b>m</b>	1	0.001	0.0254	0.305
<b>mm</b>	1000	1	25.4	305
<b>in</b>	39.37	0.0394	1	12
<b>ft</b>	3.281	0.00328	0.0833	1

### Speed

<i>1in/s--&gt;.0254m/s</i>	<b>in/s</b>	<b>in/min</b>	<b>ft/s</b>	<b>ft/min</b>	<b>m/s</b>	<b>mm/s</b>
<b>m/s</b>	0.0254	0.000423	0.305	0.00508	1	0.001
<b>in/s</b>	1	60	12	720	39.37	0.03937
<b>ft/s</b>	0.0833	5	1	60	3.281	0.003281

### Force

<i>1N --&gt; 0.224lb</i>	<b>lb(f)</b>	<b>N</b>	<b>dyne</b>	<b>oz(f)</b>	<b>kp</b>
<b>lb(f)</b>	1	4.4482	4.448 x 10 <sup>5</sup>	16	0.45359
<b>N</b>	0.22481	1	100.000	3.5967	0.10197
<b>dyne</b>	2.248 x 10 <sup>-6</sup>	0.00001	1	3.59 x 10 <sup>-5</sup>	--
<b>oz(f)</b>	0.0625	0.27801	2.78 x 10 <sup>4</sup>	1	0.02835
<b>kp</b>	2.205	9.80665	--	35.274	1

Note: lb(f) = 1slug x 1ft/s<sup>2</sup> N = 1kg x 1m/s<sup>2</sup> dyne = 1gm x 1cm/s<sup>2</sup>

### Torque

<i>1kpm --&gt; 9.807Nm</i>	<b>Nm</b>	<b>kpm</b>	<b>oz in</b>	<b>ft lb(f)</b>
<b>Nm</b>	1	9.807	0.00706	1.356
<b>kpm</b>	0.125	1	0.00072	0.138
<b>oz in</b>	141.6	1390	1	192
<b>ft lb(f)</b>	0.737	7.233	0.00521	1

### Temperature

<i>1C --&gt; 273.1K</i>	<b>° Fahrenheit</b>	<b>° Celsius</b>	<b>Kelvin</b>
<b>Kelvin</b>	(°F -305.1)/1.8	+ 273.1	1
<b>° Celsius</b>	(°F -32)/1.8	1	- 273.1
<b>° Fahrenheit</b>	1	1.8 °C + 32	1.8 K + 305.1

**Material densities**

	<b>oz/in<sup>3</sup></b>	<b>lb/in<sup>3</sup></b>	<b>g/cm<sup>3</sup></b>
<b>Aluminium</b>	1.57	0.098	2.72
<b>Magnesium</b>	1.004	0.0627	1.74
<b>Bronze</b>	4.72	0.295	8.17
<b>Copper</b>	5.15	0.322	8.91
<b>Steel</b>	4.48	0.28	7.75
<b>Plastic</b>	ca. 0.65	ca. 0.04	ca. 1.3
<b>Hardwood</b>	ca. 0.45	ca. 0.03	ca. 0.8
<b>Softwood</b>	ca. 0.3	ca. 0.02	ca. 0.5

**Abbreviations**

C	Celsius
cm	centimeter
F	Fahrenheit
ft	foot
G	Gravity
g	gram
g(f)	gram force
HP	Horse Power
in	inch
kg	kilogram
kg(f)	kilogram force
KW	Kilowatt

lb(f)	pound force
lb(m)	pound mass
min	minute
mm	millimeter
m	meter
N	Newton
oz(f)	ounce force
oz(m)	ounce mass
rad	radians
rpm	revs per minute
rps	revs per second
s	seconds

**Notes:**

Fax to Sulzer Electronics +41 (0) 1 445 22 81 or the distributor in your country

Company:	Contact:	Tel: Fax: Email:
----------	----------	------------------------

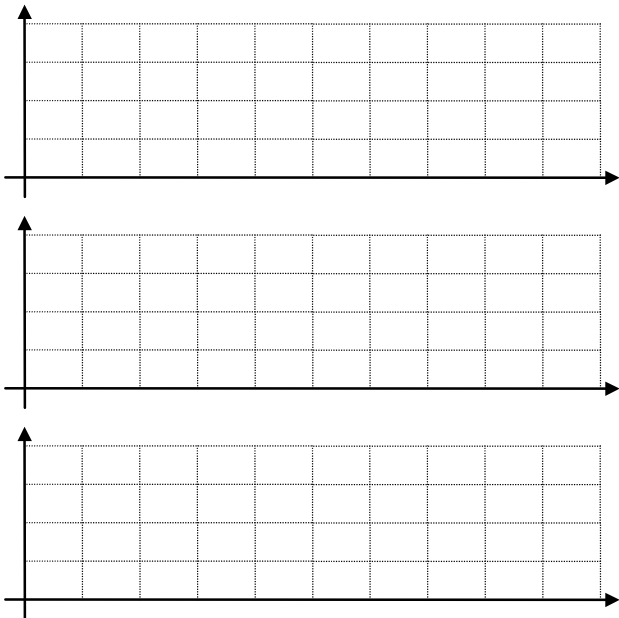
<p>Description of Application:</p>	<p>Motion Profile</p> 
------------------------------------	---

**General Data**

<sup>1</sup> Stroke (max):	<sup>2</sup> Working stroke:	<sup>3</sup> Zero position:
<sup>4</sup> Payload: <input type="radio"/> permanent <input type="radio"/> switching payload		
<sup>5</sup> Additional force (spring, ...):	<sup>6</sup> Friction:	<sup>7</sup> Force limitation:
<sup>8</sup> Repeatability:	<sup>9</sup> Absolute accuracy:	<sup>10</sup> Stiffness:

**Environment**

<sup>11</sup> Orientation: <input type="radio"/> horizontal <input type="radio"/> vertical <input type="radio"/> inclined <input type="radio"/> variable <input type="radio"/> special:		
<sup>12</sup> Radial force:	<sup>13</sup> External support:	<sup>14</sup> Power-off safety:
<sup>15</sup> Distance motor-electronics:	<sup>16</sup> Operating temperature:	<sup>17</sup> Mounting/Heat sink:
<sup>18</sup> Contamination: <input type="radio"/> clean room <input type="radio"/> food industry <input type="radio"/> Industry <input type="radio"/> special:		

**Interfacing to Machine Control Unit**

<sup>19</sup> Control: <input type="radio"/> PLC <input type="radio"/> PC <input type="radio"/> VME <input type="radio"/> QUIN <input type="radio"/> stand-alone <input type="radio"/> other:		
<sup>20</sup> Interfacing: <input type="radio"/> analog <input type="radio"/> 2-point <input type="radio"/> trigger <input type="radio"/> multitrigger <input type="radio"/> profibus <input type="radio"/> Can-Bus <input type="radio"/> RS-232 <input type="radio"/> encoder <input type="radio"/> special:		
<sup>21</sup> Power supply: <input type="radio"/> 24V <input type="radio"/> 48V <input type="radio"/> 72V existing power supply: V A <input type="radio"/> stabilized		

**Dynamic Requirements**

<sup>22</sup> Strokes/sec:	Time per stroke:	Time between strokes:
<sup>23</sup> Velocity (max):	<sup>24</sup> Acceleration (max):	<sup>25</sup> Trailing error:
<sup>26</sup> Operating time:	<sup>27</sup> Strokes/year:	<sup>28</sup> Required life:

**Commercial Information**

<sup>29</sup> Axes/year:	<sup>30</sup> Costs (target):	<sup>31</sup> Alternative solution:
<sup>32</sup> Project time frame:		